

THIS COPY IS PROVIDED ON A RESTRICTED BASIS AND IS NOT TO BE USED IN ANY WAY DETRIMENTAL TO THE INTERESTS OF PANDUIT CORP.

NOTES:

1. VISIT OUR ON-LINE CATALOG AT WWW.PANDUIT.COM FOR A LIST OF CURRENT PARTS APPLICABLE FOR USE WITH THIS PRODUCT.
2. DIMENSIONS IN [ ] ARE METRIC.
3. ALL MATERIALS AND COMPONENTS USED MEET THE MATERIAL RESTRICTIONS OF RoHS (EUROPEAN DIRECTIVE 2011/65/EU ON THE RESTRICTION OF HAZARDOUS SUBSTANCES) AS PROPOSED BY THE RoHS TECHNICAL ADAPTATION COMMITTEE.
4. WEIGHT: 1.2 LB (544 g)/1 PC
5. PART INCLUDES:
  - 1- HDMI RETRACTOR CABLE w/4ft RETRACTABLE SOURCE END AND 4ft FIXED DISPLAY END
  - 1- MOUNTING BRACKET
  - 1- CORD PASS-THROUGH FACEPLATE

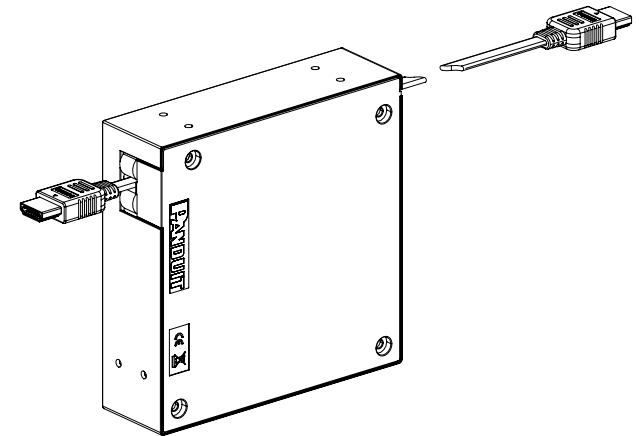
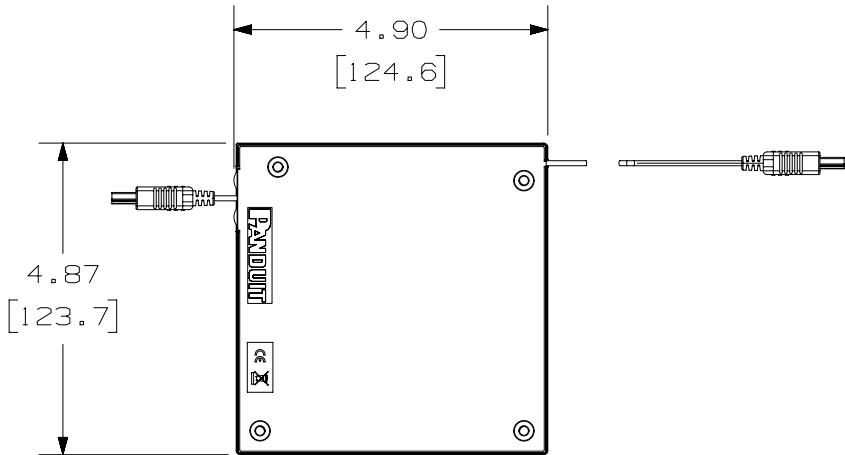
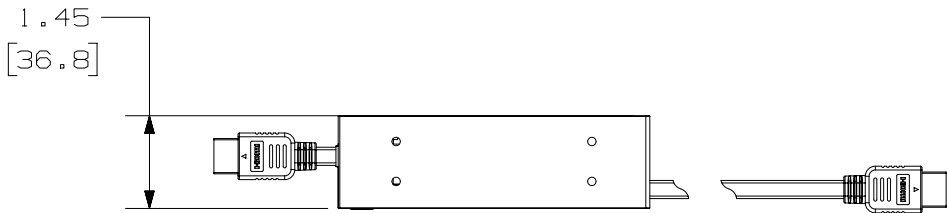
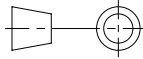

PART NUMBER		PND400		
TITLE		HDMI RETRACTOR CABLE W/ BRACKET		
		CUSTOMER DRAWING		
ITEM REVISION NAME		00101EBN/01		
DATASET FILE NAME		00101EBN_DC/01B		
		THIRD ANGLE PROJECTION		
MATERIAL		SEE NOTE 5		
		DRAWING NUMBER 00101EBN-DC		
DRAWN BY	DATE	CHK	SCALE	SIZE
BJN	4-9-18	JCO	NONE	A

01B	9-10-18	BJN	JCO	MINO	UPDATED	00101EBN-DC
REV	DATE	BY	CHK	APR	DESCRIPTION	ECN

2

1

2

1

A-SIZE CUSTOMER