



ATLONA
Connecting technology to your world

USER MANUAL

MULTI-SYSTEM PAL/NTSC/SECAM CONVERTER CDM-660



Toll free: 1-877-536-3976
Local: 1-408-962-0515



www.atlona.com

TABLE OF CONTENTS

1. Introduction	3
2. Precautions	3
3. Features	3
4. Operation Controls and Functions	4
4.1. Front Panel	4
4.2. Rear Panel	4
5. Connection and Installation	5
6. Specifications	5
7. Safety Information	6
8. Warranty	7
9. Atlona Product Registration	8

INTRODUCTION

Thank you for purchasing the CDM-660 Multi-system PAL/NTSC/SECAM Converter. This product has many innovative features that will prove absolutely useful to you. Please read this instructions carefully as it will guide you through the most of the setup process. In case of assistance with troubleshooting, please contact us.

PRECAUTIONS

1. Do not expose this product to direct sunlight.
2. Keep the unit away from radiator, heat sources and magnetic field.
3. Do not place it in very dusty or humid locations.
4. Use this unit in a horizontal position only.
5. Do not put heavy object on top of the converter.
6. Put the unit in an open space that has a good ventilation.
7. If the picture is affected. Keep the unit away from TV or other electronic equipment.
8. Unplug the unit from the power supply when it is not to be used for a long period of time.

FEATURES

- Built in Color bar.
- Input auto detecting.
- Digital conversion from input TV signals of NTSC, N4, PAL, PAL M, PAL N, SECAM to output signals of NTSC, PAL.
- Digital line (525 ⇌ 625 lines) and field (60 input ⇌ 50 field) conversion.
- 6M bit field memory.



OPERATION CONTROLS AND FUNCTIONS

4.1 Front Panel

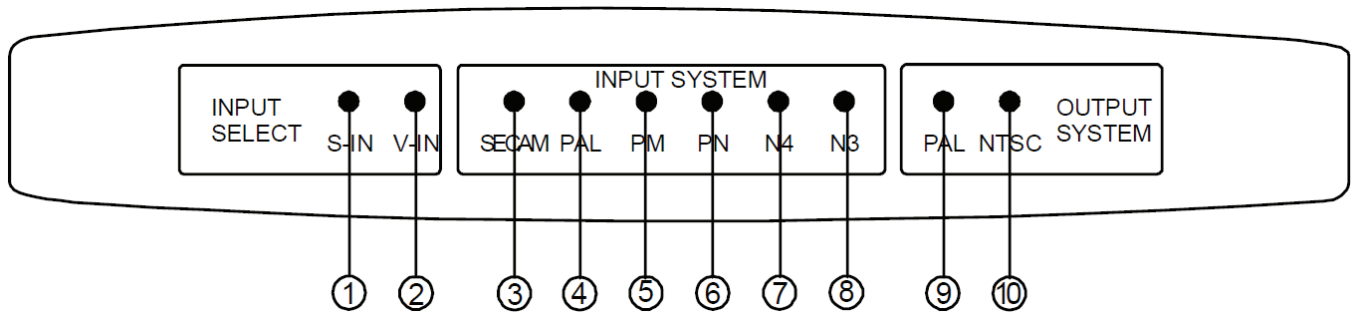

1. Illuminates when S-IN is selected.
2. Illuminates when V-IN is selected.
3. Illuminates when input system is SECAM.
4. Illuminates when input system is PAL.
5. Illuminates when input is PAL M.
6. Illuminates when input is PAL N.
7. Illuminates when input is NTSC 4.43.
8. Illuminates when input is NTSC 3.58.
9. Illuminates when output system is PAL.
10. Illuminates when output system is NTSC. Note: When no signal is selected, led 3~led 8 will illuminate in sequence, and the unit will output a color bar pattern.

4.2 Rear Panel

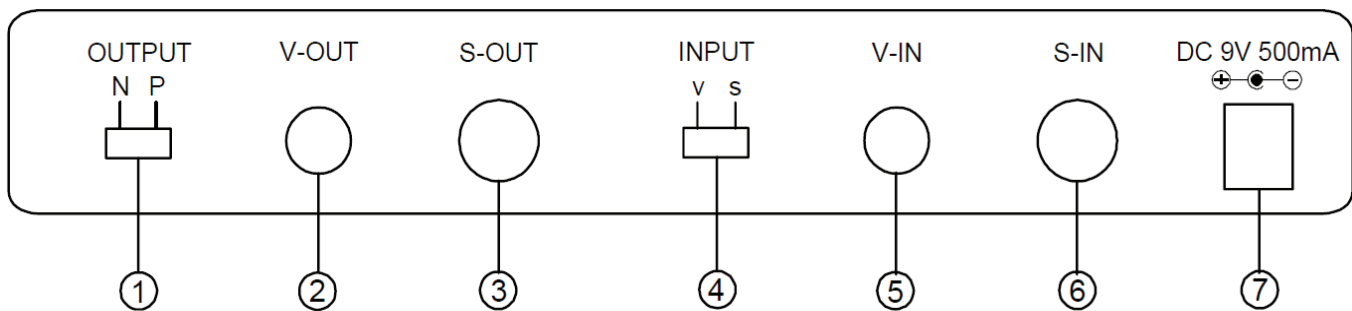

1. Output system select switch:
Set the switch to the type of signal you wish to output.
N,P stand for output signals of PAL, NTSC 3.58, respectively.
2. Video output.
3. S-Video output.
4. Input signal select switch: Set the switch to select V-In or S-In.
5. Video Input.
6. S-Video Input.
7. DC power supply input.



CONNECTION AND INSTALLATION

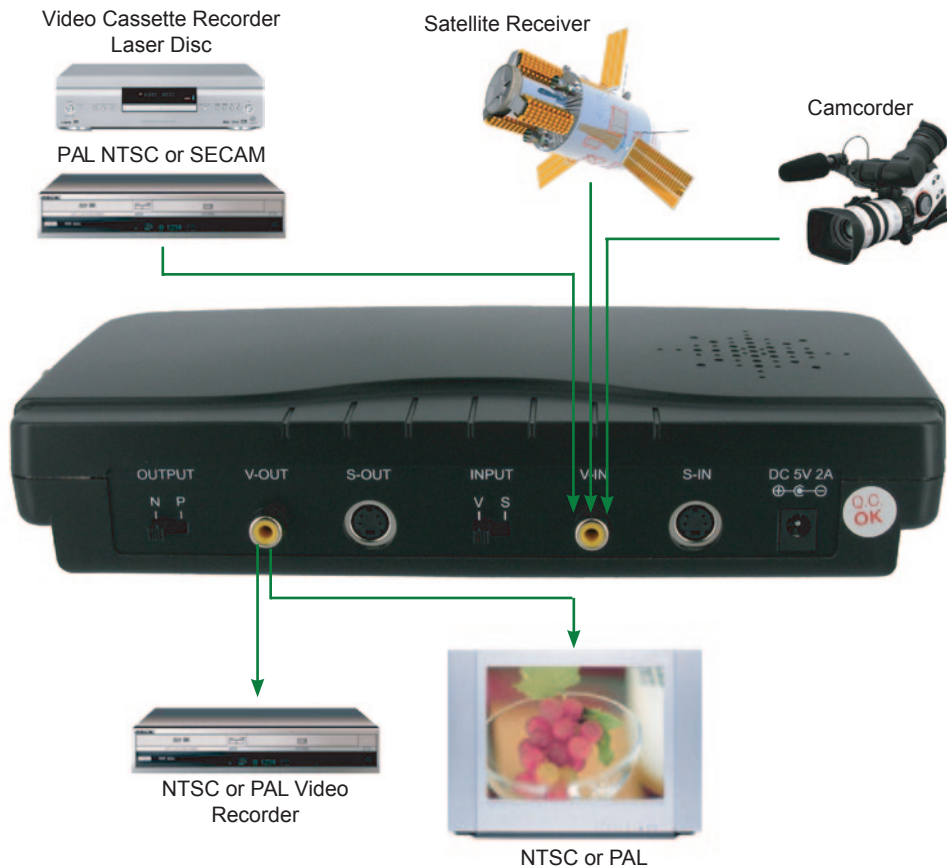

SPECIFICATIONS

Input systemsN	TSC, N4, PAL, PAL M, PAL N, SECAM
Output TV SystemsN	TSC 3.58, PAL
Connection Terminals	Video input: 1 S input : 1 Video output: 1 S output: 1
Sampling Frequency	Y: 13.5 MHz R-Y: 6.75 MHz B-Y: 6.75 MHz
Digital code bitR	: 8 bits G: 8 bits B: 8 bits
Line	525 ↔ 625
Field	60 ↔ 50
Power	DC 9V 500mA
Dimension	236(W) x 130(D) x 45(H) mm
Weight	400 g
AccessoryO	ne set of video cable, AC adaptor

SAFETY INFORMATION

Safeguards



To reduce the risk of electric shock, do not expose this product to rain or moisture



Do not modify the wall plug. Doing so will void the warranty and safety features.



If the wall plug does not fit into your local power socket, hire an electrician to replace your obsolete socket.



This equipment should be installed near the socket outlet and the device should be easily accessible in the case it requires disconnection.

Precautions

FCC regulations state that any unauthorized changes or modifications to this equipment, not expressly approved by the manufacturer, could void the user's authority to operate this equipment.

Operate this product using only the included external power supply. Use of other power supplies could impair performance, damage the product, or cause fires.

In the event of an electrostatic discharge this device may automatically turn off. If this occurs, unplug the device and plug it back in.

Protect and route power cords so they will not be stepped on or pinched by anything placed on or against them. Be especially careful of plug-ins or cord exit points from this product.

Avoid excessive humidity, sudden temperature changes or temperature extremes.

Keep this product away from wet locations such as bathtubs, sinks, laundries, wet basements, fish tanks, and swimming pools.

Use only accessories recommended by Atlona to avoid fire, shock, or other hazards.

Unplug the product before cleaning. Use a damp cloth for cleaning and not cleaning fluid or aerosols. Such products could enter the unit and cause damage, fire, or electric shock. Some substances may also mar the finish of the product.

Never open, remove unit panels, or make any adjustments not described in this manual. Attempting to do so could expose you to dangerous electrical shock or other hazards. It may also cause damage to your CDM-660. Opening the product will void the warranty.

Do not attempt to service the unit. Disconnect the product and contact your authorized Atlona reseller or contact Atlona directly.

WARRANTY

Limited Warranty

Atlona Technologies warrants that (a) its products (the CDM-660) will perform substantially in accordance with the accompanying written materials for a period of 3 years from the date of receipt and (b) that the product will be free from defects in materials and workmanship under normal use and service for a period of 3 years. In the event applicable law imposes any implied warranties, the implied warranty period is limited to 3 years from the date of receipt. Some jurisdictions do not allow such limitations on duration of an implied warranty, so the above limitation may not apply to customers that fall within those areas.

Customer Remedies

Atlona Technologies' and its suppliers' entire liability and Customer's exclusive remedy shall be, at Atlona Technologies' decision, either return of the price paid for the product, repair, or replacement of the product that does not meet this Limited Warranty and which is returned to Atlona Technologies with a copy of the Customer's receipt. This Limited Warranty is void if failure of the product has resulted from accident, abuse, misapplication, or natural occurrence. In example but not limited to: power surges (electrical storms, local power outage), dropping the product (or items on the product), contact with fluids, and physical misconduct (i.e. kicking or punching). Any replacement product will be warranted for the remainder of the original warranty period.

No other warranties

To the maximum extent permitted by applicable law, Atlona Technologies and its suppliers disclaim all other warranties, either expressed or implied, including, but not limited to, implied warranties of merchantability and fitness for a particular purpose, with regard to the product and any related written materials. This Limited Warranty gives customer specific legal rights. Customers may have other rights depending on the jurisdiction.

No liability for damages

To the maximum extent permitted by applicable law, in no event shall Atlona Technologies or its suppliers be liable for any damages arising out of the use of or inability to use this product, even if Atlona Technologies has been advised of the possibility of such damages. Such damages include but are not limited to: special, incidental, consequential, or indirect damages for personal injury, loss of business profits, business interruption, loss of business information, or any other pecuniary loss. Atlona Technologies' and its suppliers' entire liability under any provision of this agreement shall be limited to the amount actually paid by you for the product. Some Jurisdictions do not allow the exclusion or limitation of liability for consequential or incidental damage. The above limitations may not apply to you in such jurisdictional cases.

ATLONA PRODUCT REGISTRATION

Thank you for purchasing this Atlona product. - We hope you enjoy it and will take an extra few moments to register your new purchase.

Registration creates an ownership record if your product is lost or stolen and helps ensure you'll receive notification of performance issues and firmware updates.

At Atlona, we respect and protect your privacy, assuring you that your registration information is completely secure. Atlona product registration is completely voluntary and failure to register will not diminish your limited warranty rights.

To register go to: <http://www.atlona.com/registration>