

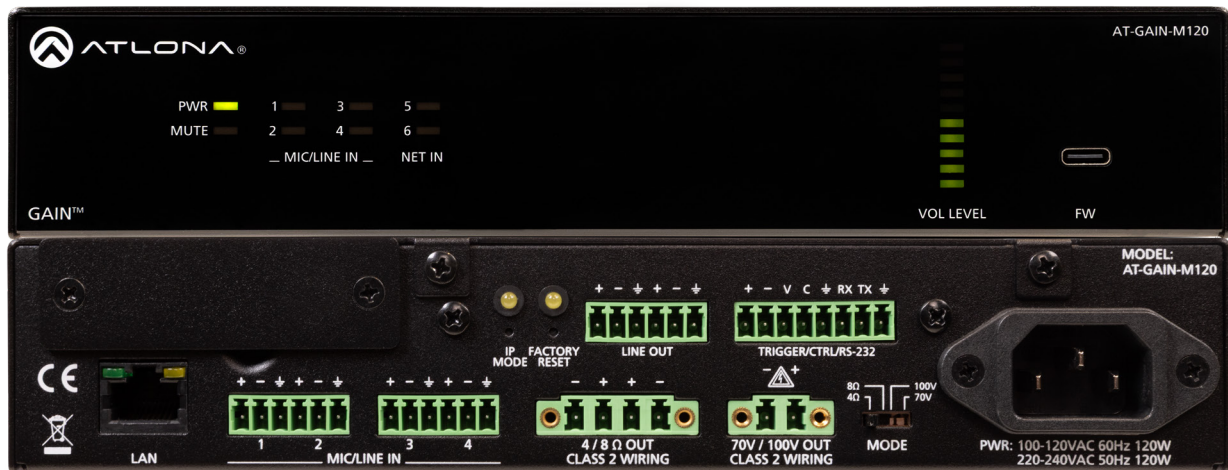

Stereo / Mono Mixer Amplifier

120 / 240 Watt



AT-GAIN-M120
AT-GAIN-M240

Atlona Manuals
Audio

Version Information

Version	Release Date	Notes
1	Mar 2026	Initial release

Sales, Marketing, and Customer Support

Main Office

Atlona Incorporated
1234 Lakeshore Dr Ste. 150
Coppell, TX 75019
United States
Office: +1.408.962.0515

International

+41 43 508 4321 (EMEA)
+65 6305 7575 (APAC)

Sales and Customer Service Hours
Monday - Friday: 09:00 - 17:00 (UTC +1)

Sales and Customer Service Hours
Monday - Friday: 8:00 a.m. - 6:30 p.m. (MST)

<https://atlona.com/>

Operating Notes



IMPORTANT: Visit <https://www.atlona.com/product/at-gain-m120> and <https://www.atlona.com/product/at-gain-m240> for the latest firmware.



NOTE: The instructions in this User Manual apply to both the AT-GAIN-M120 and AT-GAIN-M240. Both products are identical, except for the wattage.

Warranty



To view the product warranty, use the following link or QR code:

<https://atlona.com/warranty/>.

Safety and Certification



The lightning flash with arrowhead symbol, within an equilateral triangle, is intended to alert the user to the presence of uninsulated “dangerous voltage” within the product’s enclosure that may be of sufficient magnitude to constitute a risk of electric shock to persons.

Das Symbol des Blitzzeichens innerhalb eines gleichseitigen Dreiecks soll den Benutzer davor warnen, dass innerhalb des Gehäuses gefährlich hohe Spannung an berührbaren Teilen anliegt. Die Spannung ist hoch genug um bei Berührung zu einem gefährlichen elektrischen Schlag zu führen!

三角形內帶有箭頭符號的閃電，旨意在提醒用戶產品外殼內存在未絕緣的“危險電壓”可能會造成人體觸電危險

Вспышка молнии с символом стрелки в треугольнике предназначена для предупреждения пользователя о наличии неизолированного «опасного напряжения» в корпусе продукта, которое может иметь достаточную величину, чтобы представлять опасность поражения электрическим током для людей

Le flash lumineux dans le symbole de la flèche du triangle équilatéral est destiné à alerter l'utilisateur de la présence d'une «tension dangereuse» non isolée dans l'enceinte du produit qui peut être suffisamment importante pour constituer un risque d'électrocution pour les personnes

Il simbolo del lampo con la punta di una freccia, all'interno di un triangolo equilatero, avvisa l'utente della presenza di “tensioni pericolose” non isolate all'interno del contenitore del prodotto che possono essere sufficientemente elevate da costituire un rischio di folgorazione per le persone.

El símbolo del rayo con punta de flecha dentro de un triángulo equilátero alerta al usuario de la presencia de “voltaje peligroso” no aislado en el interior del producto que puede ser de una magnitud suficiente como para constituir un riesgo de descarga eléctrica para las personas.



CAUTION: TO REDUCE THE RISK OF ELECTRIC SHOCK DO NOT OPEN ENCLOSURE OR EXPOSE TO RAIN OR MOISTURE. NO USER-SERVICEABLE PARTS INSIDE REFER SERVICING TO QUALIFIED SERVICE PERSONNEL.



The exclamation point within an equilateral triangle is intended to alert the user to the presence of important operating and maintenance instructions in the literature accompanying the product.



The information bubble is intended to alert the user to helpful or optional operational instructions in the literature accompanying the product.

1. Read these instructions.
2. Keep these instructions.
3. Heed all warnings.
4. Follow all instructions.
5. Do not use this product near water.
6. Clean only with a dry cloth.
7. Do not block any ventilation openings. Install in accordance with the manufacturer's instructions.
8. Do not install or place this product near any heat sources such as radiators, heat registers, stoves, or other apparatus (including amplifiers) that produce heat.
9. Do not defeat the safety purpose of a polarized or grounding-type plug. A polarized plug has two blades with one wider than the other. A grounding type plug has two blades and a third grounding prong. The wide blade or the third prong are provided for your safety. If the provided plug does not fit into your outlet, consult an electrician for replacement of the obsolete outlet.
10. Protect the power cord from being walked on or pinched particularly at plugs, convenience receptacles, and the point where they exit from the product.
11. Only use attachments/accessories specified by Atlona.
12. To reduce the risk of electric shock and/or damage to this product, never handle or touch this unit or power cord if your hands are wet or damp. Do not expose this product to rain or moisture.
13. Unplug this product during lightning storms or when unused for long periods of time.
14. Refer all servicing to qualified service personnel. Servicing is required when the product has been damaged in any way, such as power-supply cord or plug is damaged, liquid has been spilled or objects have fallen into the product, the product has been exposed to rain or moisture, does not operate normally, or has been dropped.



FCC Compliance

FCC Compliance and Advisory Statement: This hardware device complies with Part 15 of the FCC rules. Operation is subject to the following two conditions: 1) this device may not cause harmful interference, and 2) this device must accept any interference received including interference that may cause undesired operation. This equipment has been tested and found to comply with the limits for a Class A digital device, pursuant to Part 15 of the FCC Rules. These limits are designed to provide reasonable protection against harmful interference in a commercial installation. This equipment generates, uses, and can radiate radio frequency energy and, if not installed or used in accordance with the instructions, may cause harmful interference to radio communications. However there is no guarantee that interference will not occur in a particular installation. If this equipment does cause harmful interference to radio or television reception, which can be determined by turning the equipment off and on, the user is encouraged to try to correct the interference by one or more of the following measures: 1) reorient or relocate the receiving antenna; 2) increase the separation between the equipment and the receiver; 3) connect the equipment to an outlet on a circuit different from that to which the receiver is connected; 4) consult the dealer or an experienced radio/TV technician for help. Any changes or modifications not expressly approved by the party responsible for compliance could void the user's authority to operate the equipment. Where shielded interface cables have been provided with the product or specified additional components or accessories elsewhere defined to be used with the installation of the product, they must be used in order to ensure compliance with FCC regulations.

Copyright, Trademark, and Registration

© 2026 Atlona Inc. All rights reserved. "Atlona" and the Atlona logo are registered trademarks of Atlona Inc. Pricing, specifications and availability subject to change without notice. Actual products, product images, and online product images may vary from images shown here.

All other trademark(s), copyright(s), and registered technologies mentioned in this document are the properties of their respective owner(s).

Table of Contents

Introduction	7
Features	8
Package Contents	8
Panel Description	9
Front Panel	9
Rear Panel	10
Installation	11
Audio Connectors	11
MIC LINE IN / LINE OUT	11
4 / 8 Ω OUT	12
70V / 100V OUT	12
Control Connectors	13
TRIGGER	13
CTRL	13
RS-232	14
Connection Instructions	15
Connection Diagram	16
AT-GAIN-M120	16
AT-GAIN-M240	16
IP Configuration	17
Switching the IP Mode Using the Front Panel	17
Automatic Private IP Addressing (APIPA) Mode	18
Device Operation	19
LED Indicators	19
Performing a Factory Reset	20
Signal Processing 101	21
Definitions	21
Mixing and Shaping Audio	23
Mixer	23
EQ	28
More on Waves and Phase	29
The Frequency Spectrum	32
Ducking	40
Configuration and Management Interfaces	42
Web Server	42
Login	42
System > Info	43
System > Network	44
System > Users	46
Audio > EQ	47
Audio > Ducking	49
Control > Control	50
Control > RS232	51
Maintenance > System	52
Maintenance > Logs	53
Maintenance > Configuration	54
Appendix	55
Updating the Firmware	55
Updating using the built-in Web Server	55
Updating over USB	57
Rack Mount Installation	58
Specifications	59
AT-GAIN-M120	59
AT-GAIN-M240	61

Introduction

The Atlona **AT-GAIN-M120** and **AT-GAIN-M240** are mixer amplifiers designed for low or high impedance education and commercial applications. A mode selector switch allows the GAIN-M240 to deliver two channels of 120 watts each into 4 or 8 ohms, or a single channel of 240 watts at 70 or 100 volts:

- AT-GAIN-M120: 2 × 60 W into 4/8 Ω, or 1 × 120 W at 70 / 100 V
- AT-GAIN-M240: 2 × 120 W into 4/8 Ω, or 1 × 240 W at 70 / 100 V

Advanced Configuration Features

The GAIN-M120 / M240 is a highly flexible audio amplification platform that can be tailored to the specific requirements of any application:

- Configurable inputs – Four analog inputs can be configured for mono or stereo, and for mic (with phantom power support) or line level.
- Signal processing – Gain and ducking adjustments per input, plus delay, high/low-pass filters, equalization, and attenuation per output.
- Multiple output mixes – Independent mixes and gain control are available for the amplifier and line outputs.
- Ducking – Automatically reduces program audio when a priority signal (such as a teacher microphone) is present on a selected input.
- Standby mode – Reduces power consumption when the amplifier is not in use.
- Mute – Amplifier output can be muted via control interfaces (e.g., contact closure, IP, or RS-232), such as from a public-address or control system.

Control

The amplifier includes LAN and RS-232 interfaces for automated operation from Velocity™ or third-party control systems. It also supports remote volume control from the optional AT-GAIN-VOL wallplate.

Mounting

The GAIN-M120 / M240 is housed in a rack-mountable 1RU, half-rack-width enclosure and ships with a short rack ear, long rack ear, and mounting plate for installing two of the amplifiers side-by-side in a single rack space.

Networked Audio Interfaces

AT-GAIN-NET is an optional audio bridge card that accepts two channels of Dante®, AES67, or Atlona OmniStream™ encoder audio over its network interface. Additionally, the amplifier has the ability to make routes to/from available Dante® Devices via API commands.

Features

- Four analog inputs may be configured for mono or stereo as well as mic or line levels.
- On-board mixer supports gain and ducking adjustments for each input as well as delay, high/low pass filters, equalization and attenuation for each output.
- Supports separate mixes for the amplifier and line outputs.
- Selectable low or high impedance operation.
 - » AT-GAIN-M120: 2 x 60 watts @ 4 or 8 ohms or 1 x 120 watts @ 70 or 100 volts.
 - » AT-GAIN-M240: 2 x 120 watts @ 4 or 8 ohms or 1 x 240 watts @ 70 or 100 volts.
- Ducking lowers the level of program audio sources when signal is detected on the selected input.
- Balanced line level output allows the mixed signal to be passed to an assistive listening system or separate amplifier.
- Standby mode for reducing power consumption and energy costs when not in use.
- Contact closure to engage mute or standby mode from an external system.
- LAN and RS-232 interfaces for configuration as well as control from Velocity or third-party automation systems.
- Status LEDs for power, mute, and input.
- Rack-mountable 1U, half rack width enclosure.
- Integrated power supply, no external converter required.
- Optional AT-GAIN-VOL volume control wallplate.
- Optional AT-GAIN-NET network audio interface.
- Includes product insert, captive screw connectors, US power cord, short rack ear, long rack ear, and dual mounting plate.

Package Contents

AT-GAIN-M120

1 x AT-GAIN-M120
3 x 6-pin captive screw connectors
1 x 8-pin captive screw connector
1 x 4-pin 5.08 mm lock-down screw connector
1 x 2-pin 5.08 mm lock-down screw connector
2 x Rack ears (1 long, 1 short)
1 x Mount for connecting two amplifiers
1 x Product insert

AT-GAIN-M240

1 x AT-GAIN-M240
3 x 6-pin captive screw connectors
1 x 8-pin captive screw connector
1 x 4-pin 5.08 mm lock-down screw connector
1 x 2-pin 5.08 mm lock-down screw connector
2 x Rack ears (1 long, 1 short)
1 x Mount for connecting two amplifiers
1 x Product insert

Panel Description

Front Panel



1 LED Indicators

These LED indicators provide information about the state of the unit. Refer to [LED Indicators \(page 9\)](#) for more information.

- **PWR**
This LED indicator will be green when the AT-GAIN-M120 / M240 is powered.
- **MUTE**
When an output is muted, this LED indicator will be red.
- **1 - 4**
When an input is selected as an active input, the LED indicator will be green.
- **5 - 6**
These LED indicators illuminate green when the optional Dante® network audio input on the card is active

2 VOL LEVEL

Displays the output audio level in dBFS.

3 FW

Connect a USB-C cable from this port to a computer to update the firmware. Refer to [Updating the Firmware \(page 55\)](#) for more information.

Rear Panel

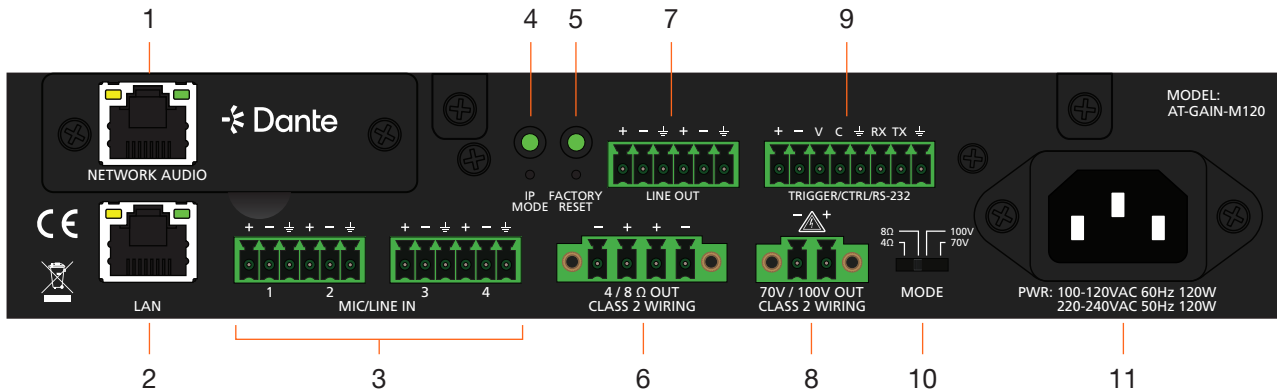

1 Network Audio

This port receives digital audio over a standard Ethernet network. This card (AT-GAIN-NET) is sold separately.

2 LAN

Connect an Ethernet cable from this port to the network. This is required if using the built-in Web UI.

3 MIC / LINE IN

Connect the included captive screws connectors to this ports to microphone and line-level audio inputs.

4 IP MODE

Press this recessed button to set the IP mode of the AT-GAIN-M120 / M240. Refer to [IP Configuration \(page 17\)](#) for more information.

5 FACTORY RESET

Press this recessed button to reset the AT-GAIN-M120 / M240 to factory-default settings. Refer to [Performing a Factory Reset \(page 20\)](#) for more information.

6 4 / 8 Ω OUT

Connect the included 4-pin captive screw connector from this port to a pair of program / stereo speakers.

- AT-GAIN-M120**
 Supports 2 x 60 watts @ 4/8 ohms amplifier (stereo or dual mono) or 1 x 120 watts @ 4/8 ohms (bridged). Use the **MODE** switch in accordance with the output impedance / voltage that is being used.
- AT-GAIN-M240**
 Supports 2 x 120 watts @ 4/8 ohms amplifier (stereo or dual mono) or 1 x 240 watts @ 4/8 ohms (bridged). Use the **MODE** switch in accordance with the output impedance / voltage that is being used.

7 LINE OUT

Use the included 5-pin captive screw connector to connect to an audio DSP or audio mixer.

8 70V / 100V OUT

Connect the included 2-pin captive screw connector from this port to 70 V or 100 V speakers. Use the **MODE** switch in accordance with the output that is being used.

9 TRIGGER / CTRL / RS-232

This port provides multiple functions. Refer to [Control Connectors \(page 13\)](#) for more information.

- TRIGGER (+, -)**
 Receives input/output from external devices, such as a PA system.
- RS-232 (TX, RX, $\frac{1}{2}$)**
 Used to connect the AT-GAIN-M120 / M240 to a control system.
- CTRL (V, C, $\frac{1}{2}$)**
 Used to connect the AT-GAIN-VOL to control volume.

10 MODE

This four-position switch selects between four speaker output settings: **4Ω**, **8Ω**, 70V, or 100V.

Installation

Audio Connectors

The AT-GAIN-M120 and AT-GAIN-M240 provide ports for **MIC/LINE IN**, **LINE OUT**, a program/stereo speaker output, and a distributed speaker output. The **MIC/LINE IN** ports can be used to connect an audio digital signal processor (DSP) or other audio source device. Balanced and unbalanced wiring is supported.

The **LINE OUT** port can be used to connect an audio output device or can be used to daisy-chain another amplifier.

1. Use wire strippers to remove a portion of the cable jacket.
2. Remove at least 3/16" (5 mm) from the insulation of each wire.
3. Connect the wires as shown, using either balanced or unbalanced wiring.

MIC LINE IN / LINE OUT

The wiring for the **MIC/LINE IN** and **LINE OUT** ports support either balanced or unbalanced audio, as shown. Both ports use the included 6-pin captive screw connectors.

Balanced audio using XLR connectors

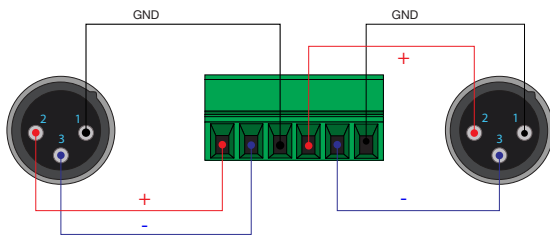

Unbalanced audio using RCA connectors

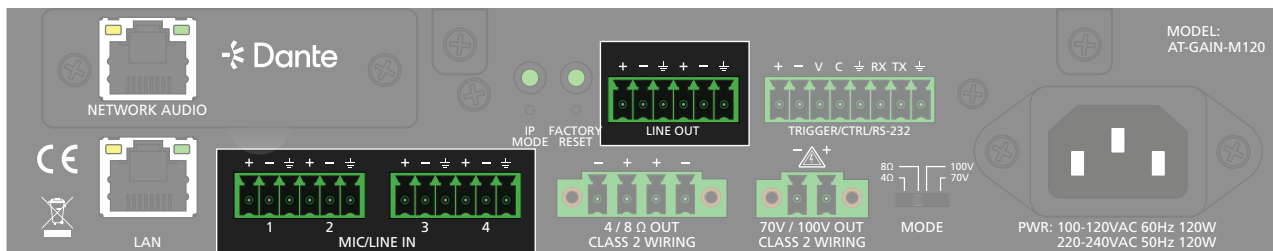
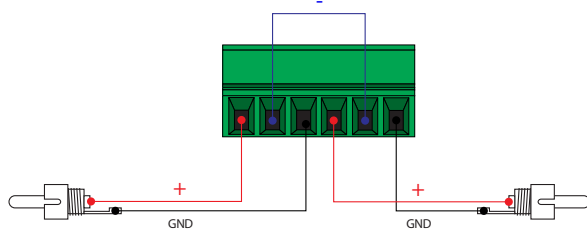

4 / 8 Ω OUT

Connect program / stereo speakers to the included 4-pin captive screw connector, then connect the terminal block to the **4 / 8 Ω OUT** port. When connecting program / stereo speakers, set the **MODE** switch to either **4 Ω** or **8 Ω**, depending upon the speaker impedance.

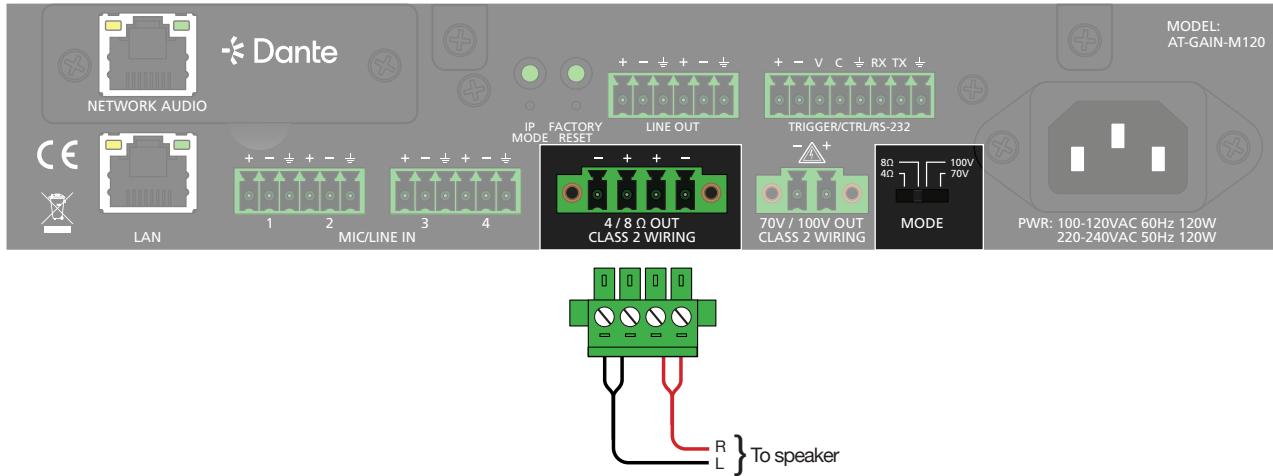

70V / 100V OUT

Connect a distributed speaker system to the included 2-pin captive screw connector, then connect the terminal block to the **70V / 100V OUT** port. When connecting program / stereo speakers, set the **MODE** switch to either **70V** or **100V**, depending upon the speakers.

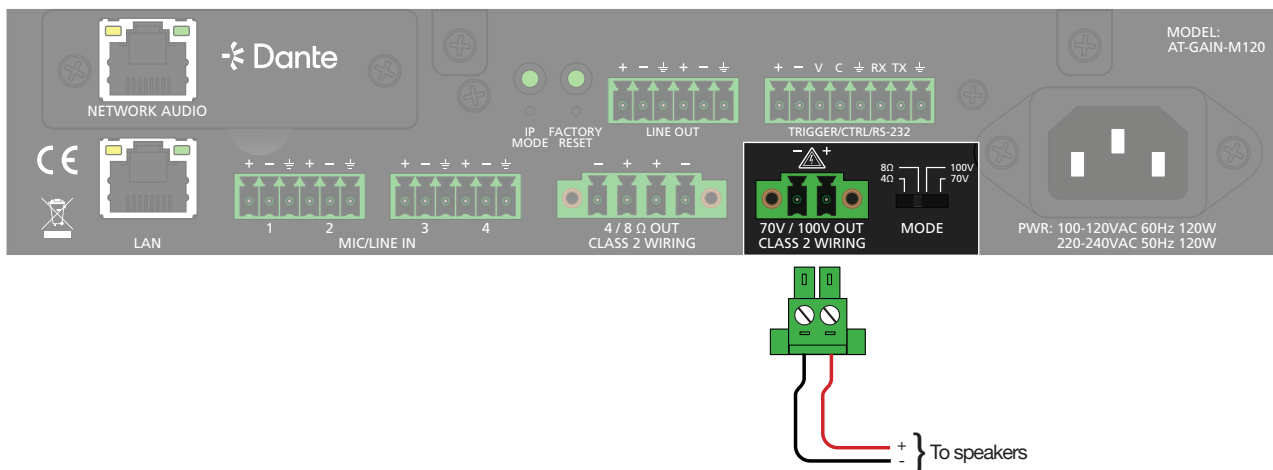

Control Connectors

TRIGGER

The **TRIGGER** port enables external control of the amplifier for integration with mass-notification and PA systems.

To set the **TRIGGER** options for either normally-open (NO) or normally-closed (NC), do the following:

1. Login to the built-in web server.
2. Go to **Control > Control**
3. Next to **Trigger Mode**, select **NO** or **NC**.

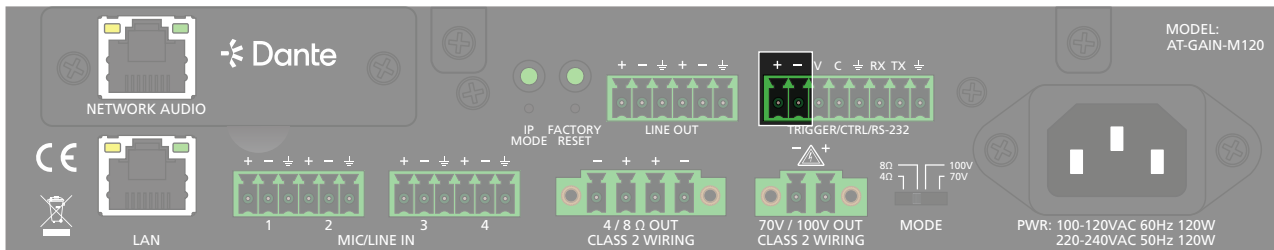
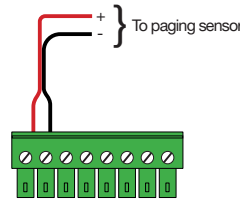

CTRL

The **CTRL** port (V, C, \perp) allows an AT-GAIN-VOL Volume Control Wallplate to be connected for remote volume adjustment from a wall- or lectern-mounted location.

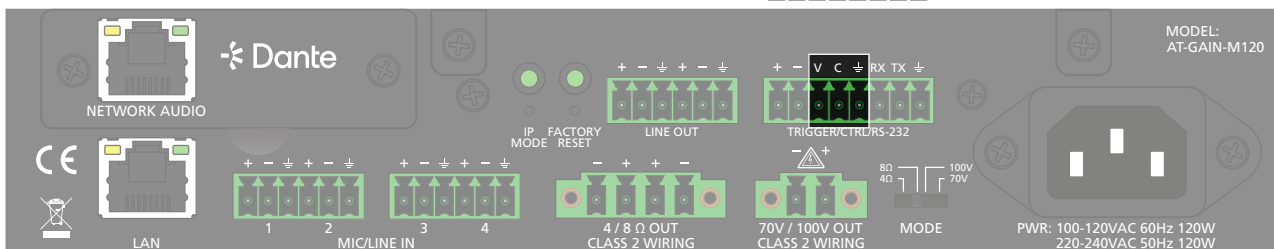
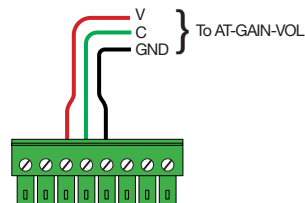

RS-232

The **RS-232** interface (RX, TX, \perp) supports connection of a control system. Connect the RS-232 cable between the control system and the RS-232 port on the AT-GAIN-M120 / M240.

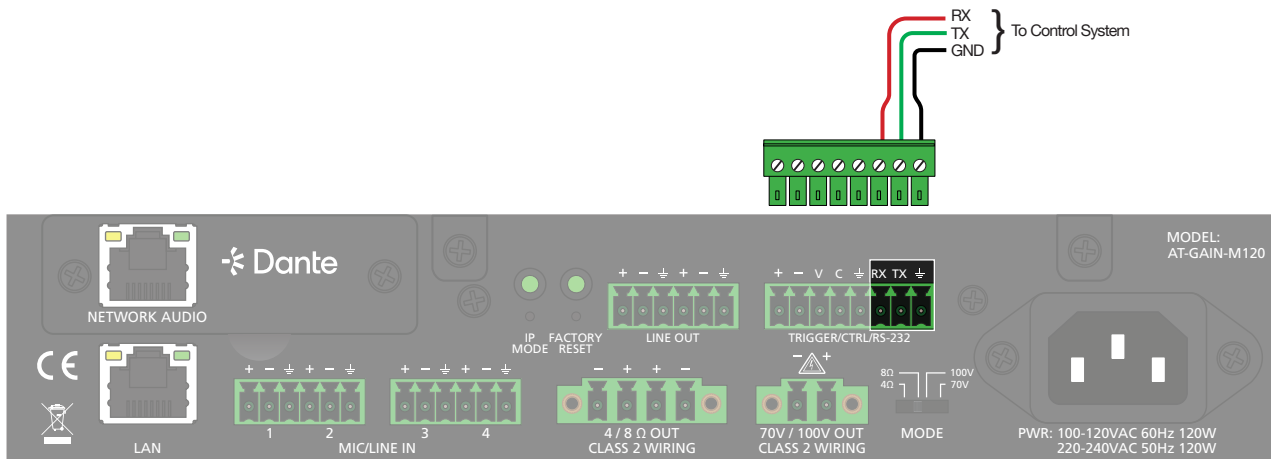

To configure RS-232, do the following:

1. Login to the built-in web server.
2. Go to **Control > RS232**.
3. Click the drop-down lists to select the required baud rate, data bits, parity, and stop bits. These settings must match the RS-232 settings on the control system.

Changes are automatically saved.

Connection Instructions

The AT-GAIN-M120 / M240 can be used with an optional network audio card, which supports Dante® and AES67 audio streams. This network card (AT-GAIN-NET) is sold separately and is available from Atlona.

1. Connect an analog audio source, using the included 6-pin captive screw connector, to the **MIC/LINE IN** ports. Use the desired wiring configuration, on the previous page. Both balanced and unbalanced wiring are supported.
2. Connect an analog audio output device, using the included 6-pin captive screw connector, to the **LINE OUT** port. Use the desired wiring configuration, on the previous page. Both balanced and unbalanced wiring are supported.



NOTE: Analog or NET audio (with the optional card) is selectable from the built-in web server, Atlona Velocity™, or third-party control using the API. In addition, the **LINE OUT** port outputs analog audio only. This port cannot output digital audio from the optional AT-GAIN-NET card.

3. Determine the use-case scenario of the AT-GAIN-M120 / M240. The AT-GAIN-M120 / M240 can be configured as either one of the following. Only one type of speaker connection is permitted at a time.
 - **Distributed speaker system (high impedance)**
Set the **MODE** switch to the required voltage setting: **70V** or **100V**. This mode is used for commercial applications and longer speaker cable runs.
 - **Program speakers / stereo (low impedance)**
Set the **MODE** switch to the impedance setting of the speakers being connected: **4Ω** or **8Ω**. This mode is used for consumer applications and shorter speaker cable runs.
4. Set the **MODE** switch to the proper setting, based on the type of speaker connection that is being used.
5. Connect the included 8-pin captive screw connector to the **TRIGGER/CTRL/RS-232** port and wire as required. Refer to [Control Connectors \(page 13\)](#) for more information.
6. Connect the **LAN** port to a network switch for set up and control of the unit.



IMPORTANT: Stranded or patch cable is not recommended due to performance issues. Shielded cables are strongly recommended to minimize signal noise and interference.

7. Connect the included IEC power cord from the power receptacle to an available electrical outlet.

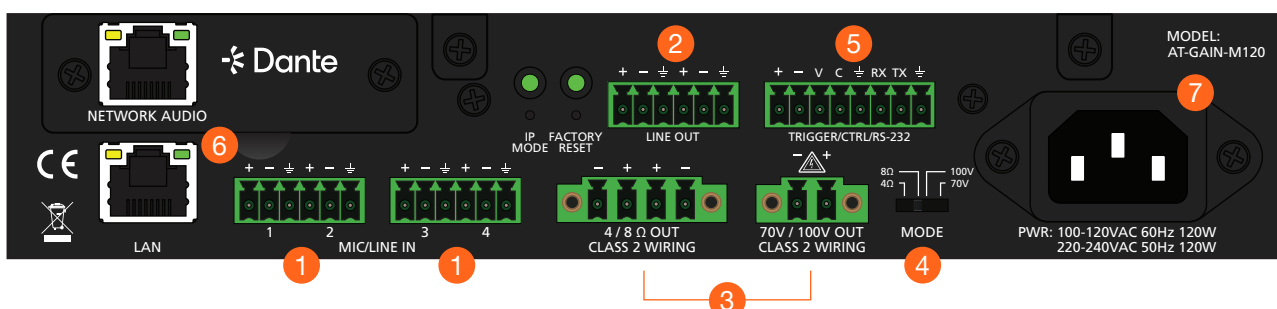

Connection Diagram

AT-GAIN-M120

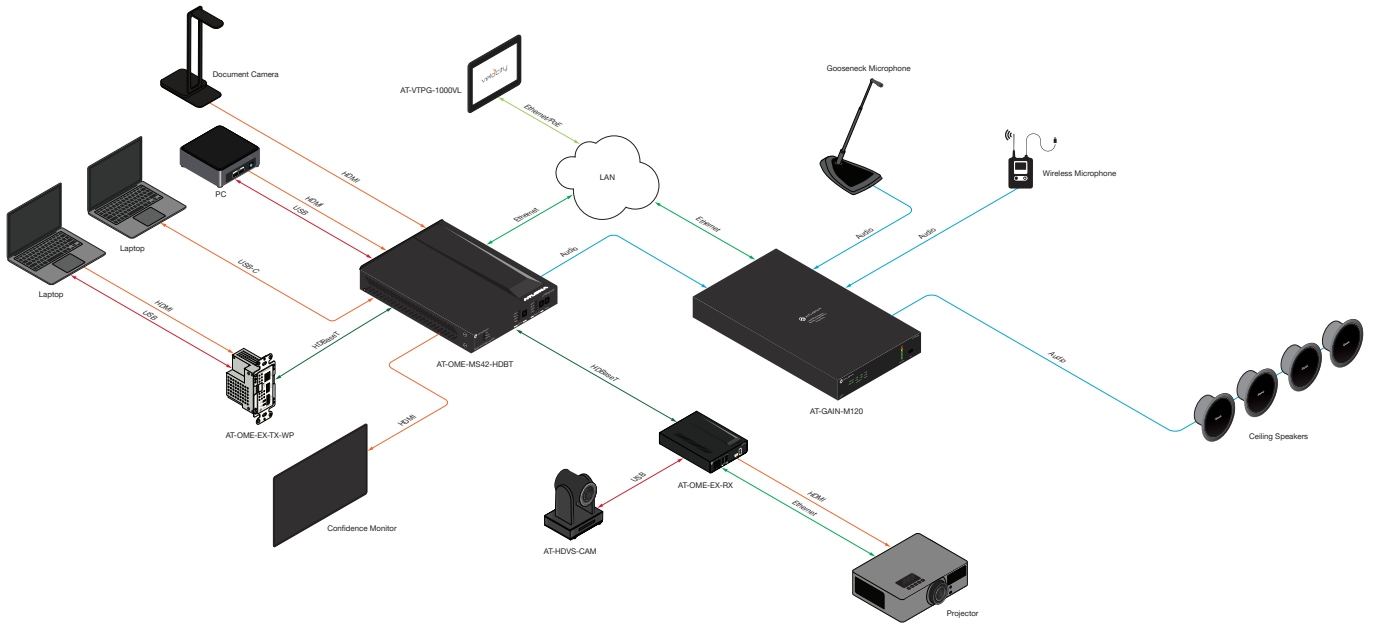

AT-GAIN-M240

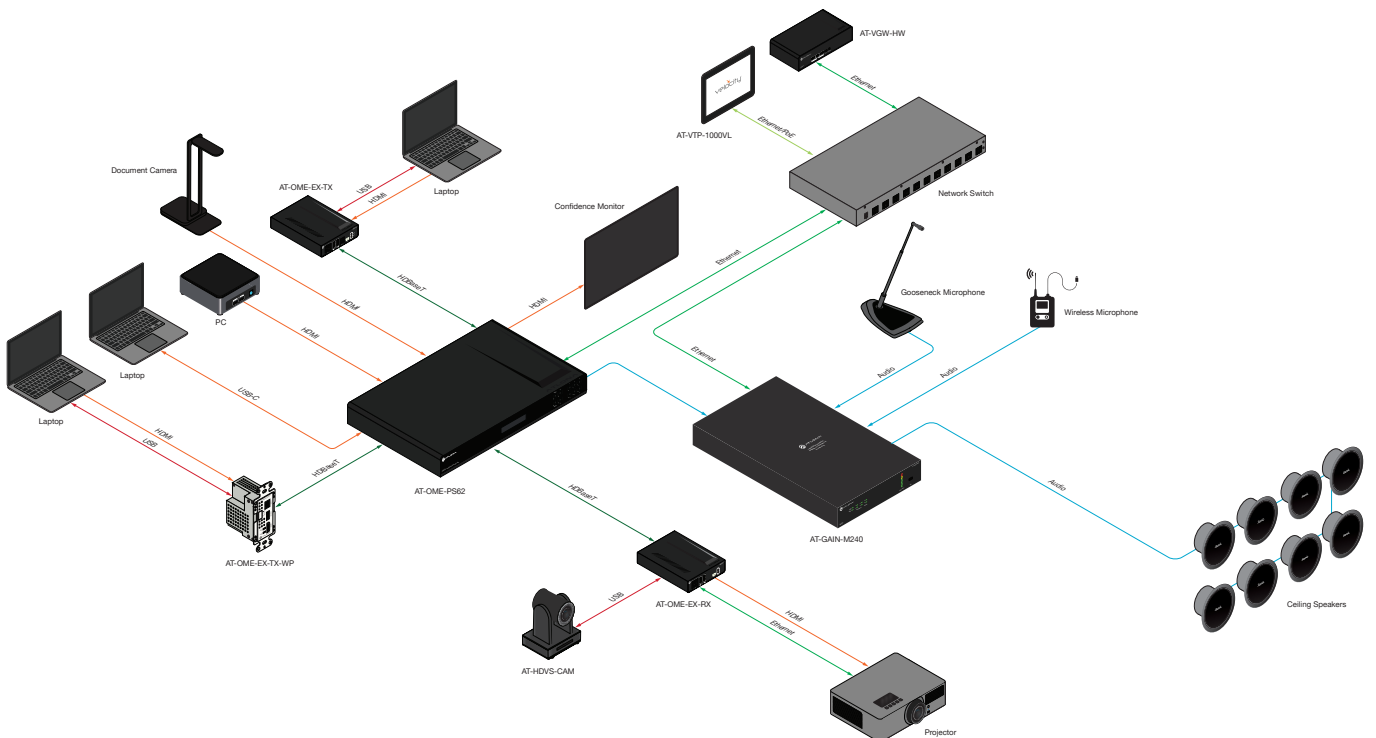

IP Configuration

The AT-GAIN-M120 / M240 is shipped with DHCP enabled. Once connected to a network, the DHCP server (if available), will automatically assign an IP address to the unit. An IP scanner, along with the MAC address on the bottom of the unit, can be used to identify the unit on the network.

Switching the IP Mode Using the Front Panel

If a static IP address is desired, the unit can be switched to static IP mode. The **IP MODE** button, on the back panel, can be used to switch between DHCP and static IP mode. The default static IP address of the AT-GAIN-M120 / M240 is 192.168.1.254. If the AT-GAIN-M120 / M240 is unable to detect a DHCP server within 15 seconds, then the unit will use a self-assigned IP address within the IPv4 address block 169.254.0.0/16. If this occurs, refer to [Automatic Private IP Addressing \(APIPA\) Mode \(page 18\)](#) for more information.

1. Make sure the AT-GAIN-M120 / M240 is powered.
2. Using a small tool, such as a plastic stylus or the end of a paperclip, gently press the IP MODE button until it engages.

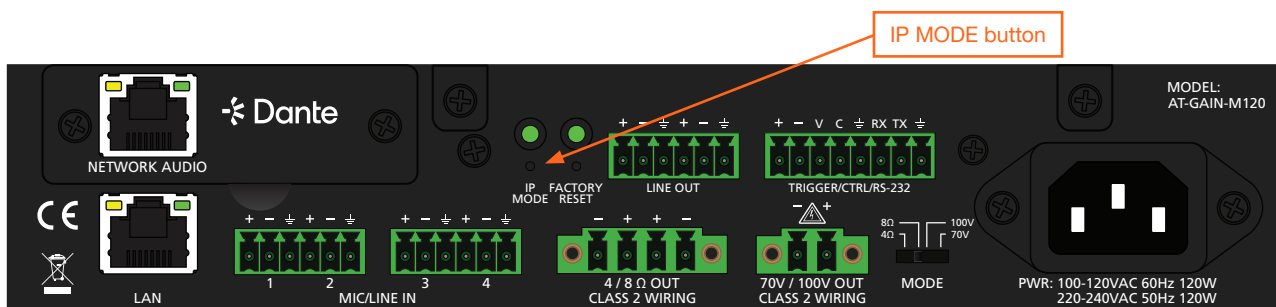

3. Hold for 10 seconds, then release.
4. The LED indicator above the button will flash twice to confirm the unit is set to Static IP mode.
5. Repeat this procedure to switch to DHCP (default) mode. When set to DHCP mode, the LED indicator will flash four times.

Input LED Indicators flash	Description
Two	DHCP mode
Four	Factory Static IP mode (IP address set to 192.168.1.254)

Automatic Private IP Addressing (APIPA) Mode

If the AT-GAIN-M120 / M240 is unable to detect a DHCP server within 15 seconds, then the unit will use a self-assigned IP address within the IPv4 address block 169.254.0.0/16. If this occurs, connect an Ethernet cable directly from the **LAN** port of the AT-GAIN-M120 / M240 to the LAN port of a computer, then perform the following:

1. Change the IP address of the computer to an unused IP address within the range 169.254.xxx.xxx/16. *The computer must not be assigned the same address as the AT-GAIN-M120 / M240.*
2. Click **Start > Settings > Control Panel > Network and Sharing Center**.
3. Click **Change adapter settings**.
4. Right-click on the adapter that is used to establish a wired connection to the network, and select **Properties** from the context menu.
5. Under the **Ethernet Properties** dialog box, select **Internet Protocol Version 4** and then click the **Properties** button. Click the **Use the following IP address** radio button.















IMPORTANT: Before continuing, write down the current IP settings in order to restore them, later. If **Obtain an IP address automatically** and **Obtain DNS server automatically** are selected, then this step is not required.

6. Enter the desired static IP address or the IP address provided by the network administrator. If the computer does not require Internet access or if a statically-assigned IP address is being used, then an address within the IPv4 address block 169.254.xxx.xxx/16 can be entered.
7. Set the subnet mask to 255.255.0.0.
8. Click the **OK** button then close all **Control Panel** windows.
9. Log in to the built-in web server to set a static IP address that can be used with the network. Contact a system administrator, if necessary. Refer to [Setting the IP Mode \(page 14\)](#) for more information.

Device Operation

LED Indicators

The LED indicators on the front panel, provide information on the current state of the AT-GAIN-M120 / M240. Refer to the table below for more information.

LED Indicator	State		Description
PWR	Solid green		Unit is powered and ready for operation.
	Off		Unit is not powered. <ul style="list-style-type: none"> • Check the power cable between the AT-GAIN-M120 / M240 and the electrical outlet. • Make sure that the electrical outlet is live.
	Rapid flashing green		Firmware update is in progress. Refer to Updating the Firmware (page 55) for more information.
	Solid amber		AT-GAIN-M120 / M240 is in standby mode or is booting.
MUTE	Solid red		Amp Out L / R are muted.
	Off		Output is not muted.
MIC/LINE IN (1 - 4)	Solid green		Input is the currently-selected input.
	Off		Input not selected.
NET IN (5 - 6)	Solid green		The INPUT port on the network card is the active input. This LED indicator is only functional when the optional AT-GAIN-NET card is installed. Note that this LED indicator does not indicate the presence of an audio signal.
	Off		The INPUT port on the network card is not the active input.
VOL LEVEL	Solid green		Audio should be free of clipping. If audio clipping is heard in this range, check the output setting or signal adjustment of the source device.
	Solid amber		Audio signals that approach the 0 dBFS level are represented in this range. If audio clipping is heard, reduce the INPUT GAIN until audio is free of distortion.
	Solid red		Audio signals which exceed 0 dBFS are represented in this range. Audio clipping occurs at this level. If clipping is heard, reduce the INPUT GAIN until the meter no longer blinks red and the audio is free of distortion.

Performing a Factory Reset

If necessary, the AT-GAIN-M120 / M240 can be reset to factory-default settings. Note that the AT-GAIN-M120 / M240 will be placed in DHCP mode, as part of the reset procedure. The AT-GAIN-M120 / M240 can also be reset through the built-in web server. Refer to [Maintenance > System \(page 52\)](#) for more information.

1. Make sure the unit is powered-on.
2. Using a small tool, such as a plastic stylus or the end of a paperclip, press the **FACTORY RESET** button until it engages.

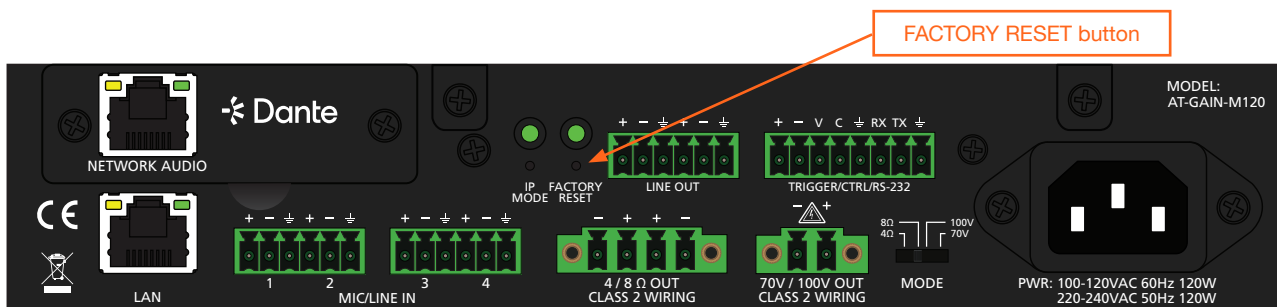

3. Hold for 10 seconds, then release.
4. The **FACTORY RESET** LED indicator will flash three times to confirm the unit has been reset.

Signal Processing 101

The AT-GAIN-M120 / M240 graphical user interface (GUI) is designed for intuitive control and detailed audio management. It is divided into three main sections: **Mixer**, **EQ**, and **Ducking**. Each section provides access to specific signal processing tools—**Mixer** handles gain, muting, phantom power, and channel modes; **EQ** offers filtering and frequency shaping; and **Ducking** controls dynamic response based on signal priority. The following pages will break down each section in detail.

Definitions

Before diving into the details of this section, it's important to first understand a few basic concepts and terms that will be used throughout. These definitions provide the groundwork for understanding how audio signals are processed, controlled, and routed within the system. For those who are new to audio, reviewing the following information will help make the rest of this section easier to follow and more meaningful.

Decibel

A decibel (dB) is the universal unit used to measure sound and audio levels. It is a relative scale, comparing one level to another rather than measuring in absolute terms—much like how a weather report might say “it’s 10 degrees warmer than yesterday” instead of giving a specific temperature. In audio, decibels describe changes in loudness, signal strength, or gain based on a reference point. Common references include dB SPL (sound pressure level), dBu, and dBV. dBu is standard in professional systems, with +4 dBu used for balanced line-level signals. dBV, where 0 dBV = 1 volt, may also appear in this manual when describing general signal levels or graphing amplitude. The reference type—such as dBu for balanced inputs—will be specified when relevant. In digital audio, dBFS (decibels Full Scale) is used, with 0 dBFS representing the maximum signal level before clipping (distortion). Understanding decibels is key to managing gain, volume, and signal flow in any audio system.

Gain

Gain is one of the most commonly misunderstood concepts in audio. It is not the same as volume. While volume controls the loudness of the *output* signal, gain adjusts the strength (or amplitude) of the *input* signal before any processing occurs. Gain is measured in decibels (dB) and is typically applied at the first stage in the signal chain. Proper gain setting is essential to ensure optimal signal levels and to prevent distortion or unwanted noise.

Amplitude

Amplitude refers to the strength (size) of an audio signal. In simple terms, it's how “big” the sound wave is, which usually makes the sound feel louder when it's bigger and quieter when it's smaller. On a waveform, amplitude is the vertical distance from the center line (zero) to the peak (or to the trough). Even though the wave swings above and below zero, amplitude is a distance (a magnitude), so it isn't negative—the negative half just means the signal is below the center line at that moment. In audio, we often describe signal level using decibels (dB), which is a standard way to compare levels relative to a reference (for example, dBFS in digital systems). Amplitude/level affects the overall volume and energy of a sound without changing its pitch (frequency).

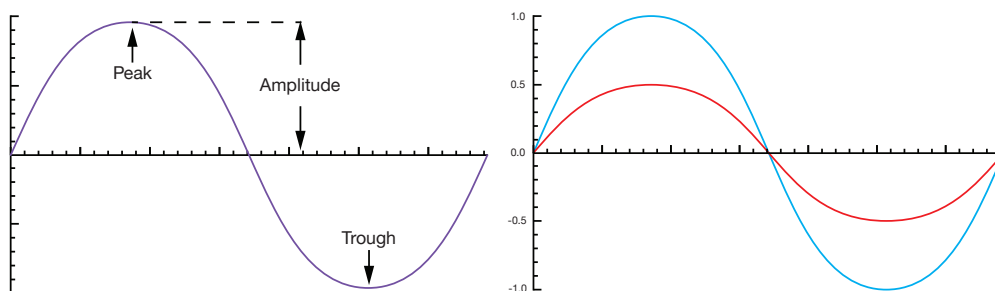

Both audio signals at n dB.

Blue audio signal at 1.0 dB.
Red audio signal at 0.5 dB.

Filter

A filter is a tool used in audio systems to shape the frequency content of a signal by allowing certain frequencies to pass while reducing others. Common types include high-pass filters (HPF), which reduce low frequencies while allowing highs to pass; low-pass filters (LPF), which reduce high frequencies while allowing lows to pass; and band-pass filters (BPF), which isolate a specific frequency range by reducing both highs and lows outside that range. Filters are defined by their cutoff frequency and slope, which determine how gradually or sharply unwanted frequencies are reduced. These concepts will be introduced and explained more clearly later in this section for those new to audio. For those with audio experience, the AT-GAIN-M120 / M240 uses *Butterworth* filters, which offer a smooth, flat response in the passband with no ripple—ideal for transparent audio control.

Frequency

Frequency refers to how often a sound wave completes a full cycle in one second and is measured in Hertz (Hz). One hertz equals one cycle per second—for example, a 440 Hz frequency completes 440 cycles each second and corresponds to the musical note A above middle C. Frequency directly affects pitch: lower frequencies (like 60 Hz) produce deep, bass-heavy sounds, while higher frequencies (like 5,000 Hz) create brighter, treble-rich tones. A change in frequency always results in a change in pitch. Frequency is also related to wavelength, which is the physical distance between repeating points on a wave (such as peak to peak). Wavelength is represented by the Greek letter lambda (λ) and is inversely related to frequency, meaning that lower frequencies have longer wavelengths, and higher frequencies have shorter ones. Understanding frequency is essential for adjusting EQ, managing tonal balance, and filtering unwanted noise.

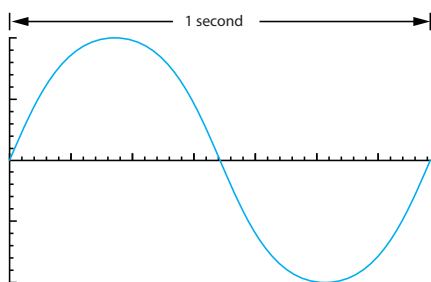

Frequency = 1 Hz.

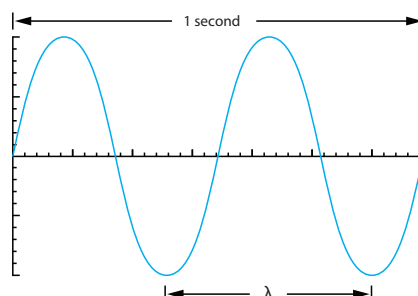

Frequency = 2 Hz.

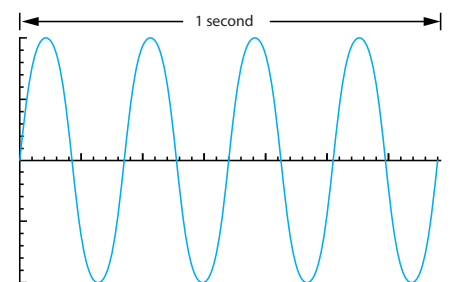

Frequency = 4 Hz.

Phase

Phase describes the timing relationship between two or more audio signals and is measured in degrees, with a full cycle representing 360°. When sound waves are in phase, their peaks and troughs align, reinforcing each other and creating a fuller, more powerful sound. When waves are out of phase, they don't align properly—this misalignment can cause the sound to become weak, hollow, or even cancel out completely at certain frequencies. This phenomenon is called *destructive interference*. Phase issues often occur when using multiple microphones or speakers, and understanding phase is important for maintaining clear, consistent audio.

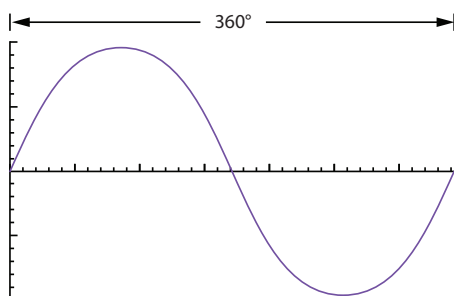

Audio signals *in phase*.

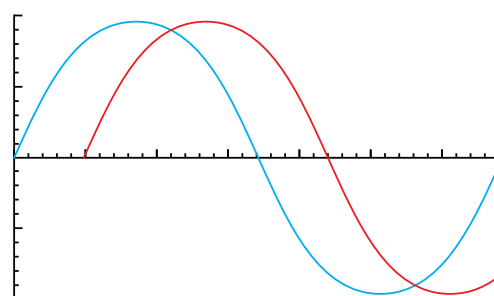

Audio signals *out of phase (phase shift)*.

Mixing and Shaping Audio

Mixer

The AT-GAIN-M120 / M240 features a built-in mixer that provides flexible routing and control of all input signals. Each output includes an independent mix for both left and right channels, with configurable input mute status and adjustable input levels from +10 dB to -60 dB in 1 dB increments. Input levels are fully independent across mixes, so adjusting the volume of an input in one output mix does not affect its level in any other mix. By default, all inputs are unmuted across all mixes. Mixer settings can be configured through the AT-GAIN-M120 / M240 web interface or using the API.



Gain

Each mix in the amplifier includes a gain control for every unmuted input, allowing precise level adjustments from +10 dB to -60 dB in 1 dB increments. Gain is applied independently per mix, meaning the level of an input in one output mix does not affect its level in another. In stereo mode, adjusting the gain on one channel (left or right) will automatically set both channels to the same level for consistency. Gain can be adjusted using the on-screen sliders or by manually entering a value into the fields located to the left of each slider.

Mute

Each input in a mix includes a **Mute** control, allowing the signal to be toggled On or Off. When set to On, the input is muted and excluded from the output mix. When set to Off, the input remains active and contributes to the mix according to its gain setting. In stereo mode, muting one channel (left or right) automatically mutes both channels to maintain stereo consistency.

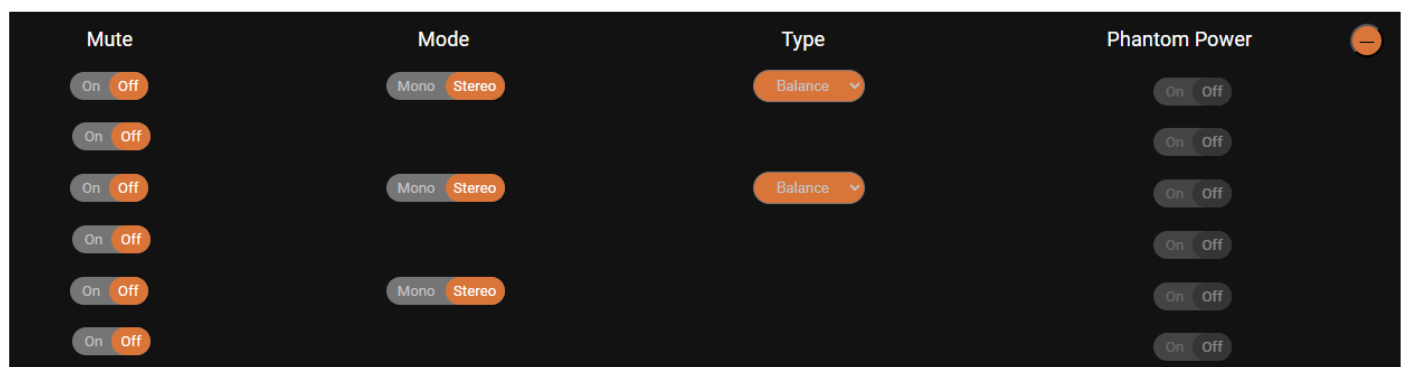

Mode

Each output mix includes a **Mode** toggle switch that can be set to either **Mono** or **Stereo**. This setting determines how gain and mute controls behave across the left and right channels. In **Mono** mode, the left and right channels can be adjusted independently. In **Stereo** mode, any change made to one channel—such as adjusting gain or muting an input—will automatically apply to both channels, ensuring consistent stereo output.

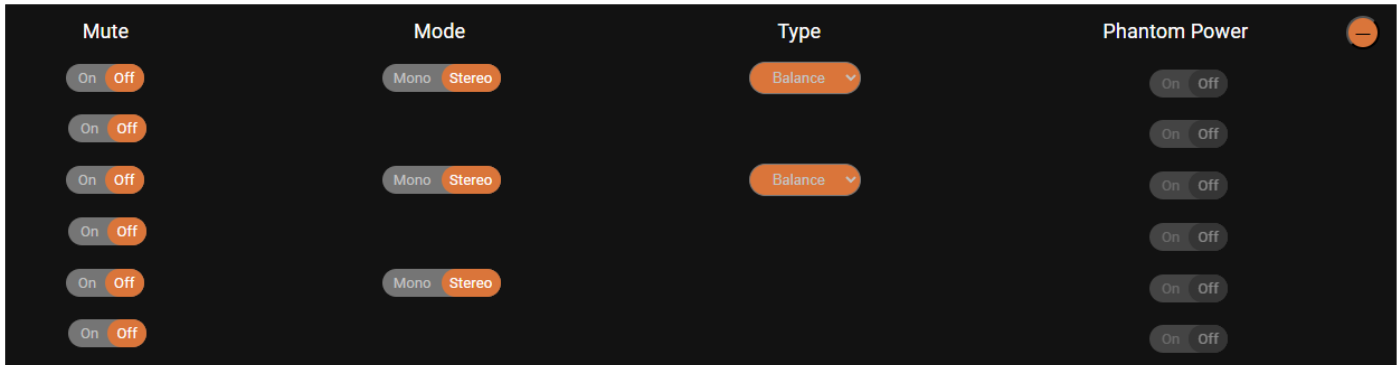

Mono vs. Stereo

Mono (monophonic) mode combines the left and right channels into a single audio signal. This is useful when driving a single loudspeaker, distributing the same sound evenly across multiple zones, or when stereo separation is not necessary. Stereo (stereophonic) mode preserves the left and right channel differences, allowing for directional sound imaging—ideal for applications where full stereo playback is important, such as music listening or media playback in a defined space.

Application	Recommended Mode	Description
Single ceiling speaker	Mono	Only one speaker; stereo separation is unnecessary.
Distributed speakers across zones	Mono	Ensures consistent sound throughout all areas, without phase issues.
Classroom or conference room audio	Mono	Speech clarity is prioritized; stereo imaging isn't required.
Media room or home theater	Stereo	Preserves left/right separation for immersive sound.
Stereo background music system	Stereo	Maintains stereo imaging for a more natural listening experience.
Outdoor or large open space with paired speakers	Stereo	Use Stereo for defined left/right placement; Mono if coverage is more important than imaging.

Type

The **Type** drop-down list allows configuration of the input type for each **Mic/Line** input, with three selectable options: **Balance**, **Unbalance**, and **Microphone**. These options help match the input circuitry to the connected audio source.

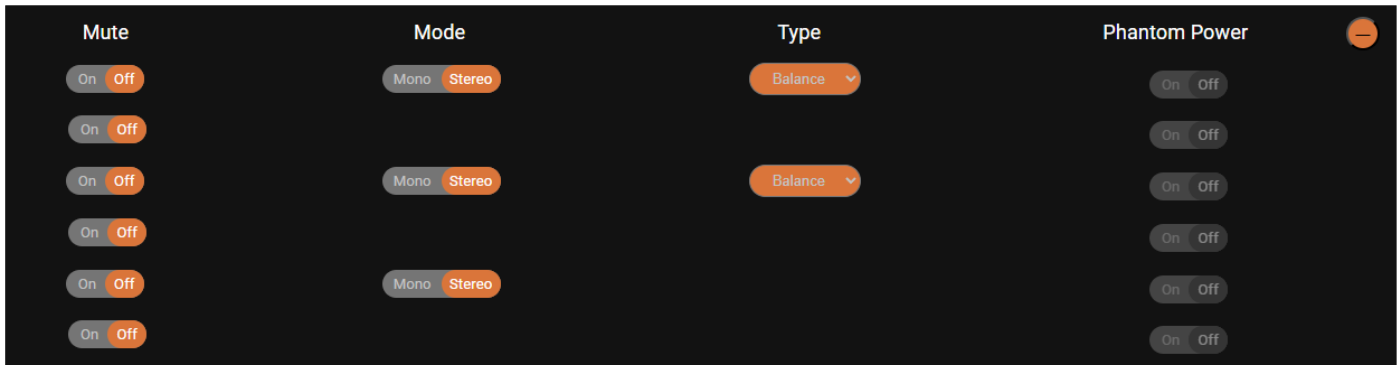

Type	Description
Balance	Commonly used in professional audio systems and long cable runs, offering superior noise rejection by using two signal conductors plus a ground. Balanced line-level signals typically operate around +4 dBu.
Unbalance	Common in consumer-grade equipment and short cable runs, using a single signal conductor and ground. These signals typically operate at -10 dBV and are more susceptible to noise over long distances.
Microphone	This setting is intended for low-level mic signals and activates the AT-GAIN-M120 / M240 internal mic preamp, which adjusts the gain and impedance to suit microphone-level input.

The number of **Type** drop-down lists displayed will vary depending on the selected Mode. When **Mode** is set to **Stereo**, only two drop-down lists appear—one for each stereo pair—since the left and right channels are treated as linked inputs. When **Mode** is set to **Mono**, four drop-down lists are displayed, allowing independent configuration of all four input channels.

Phantom Power

The **Phantom Power** feature provides 48V DC power to condenser microphones that require external power to operate. This option is only available when the **Type** is set to **Microphone**; if any other input type is selected (such as **Balance** or **Unbalance**), the phantom power toggle switches are disabled. When enabled, phantom power is delivered through the same cable that carries the audio signal—hence the term phantom, since no separate power connection is needed. This is a common requirement for condenser microphones, which rely on a powered internal circuit to function properly. Each of the four phantom power toggle switches can be independently set to **On** or **Off**, regardless of whether the system is configured in **Mono** or **Stereo** mode. Enabling phantom power for dynamic microphones or line-level equipment is generally not recommended, so it's important to activate this setting only when a compatible condenser microphone is in use.



IMPORTANT: Always check the microphone's specifications before enabling phantom power. Some dynamic microphones and certain audio equipment may not be designed to handle 48 V power and could be damaged if phantom power is applied. Only enable this setting when using microphones that explicitly require it, such as condenser models.

The **Outputs** subsection provides controls for adjusting output gain, muting individual outputs, and selecting between Stereo and Mono modes—allowing flexibility in how audio is distributed to connected speakers or zones.

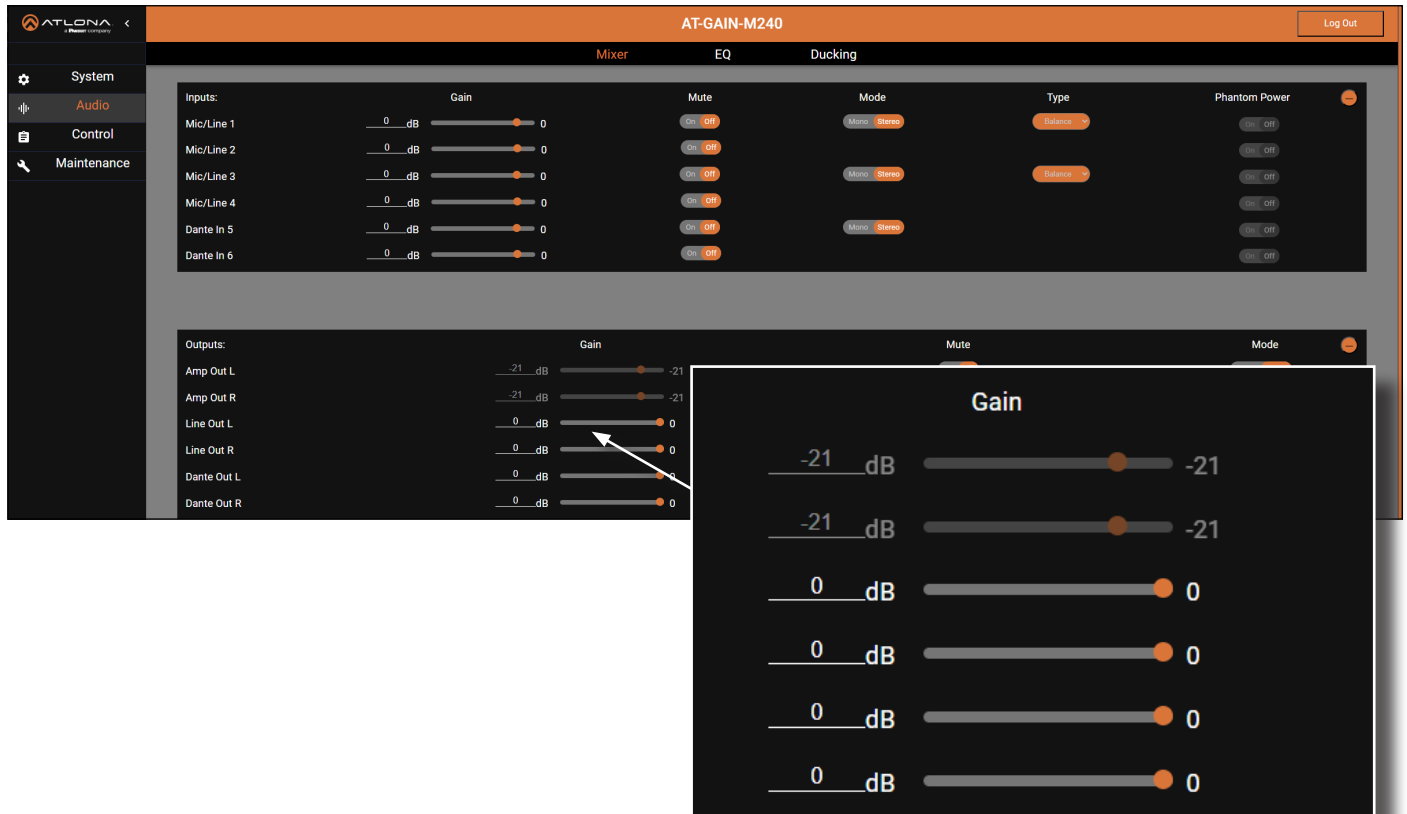

Gain

Each output includes a gain control, allowing precise adjustment of the signal level before it is sent to connected speakers or devices. A total of six gain sliders are available—one for each output channel. Gain can be adjusted from -108 dB to 0 dB in 1 dB increments. Adjustments can be made using the on-screen sliders or by entering a value directly into the **dB** fields located to the left of each slider. In **Stereo** mode, changing the gain on one channel (left or right) will automatically apply the same level to both channels to maintain balance.

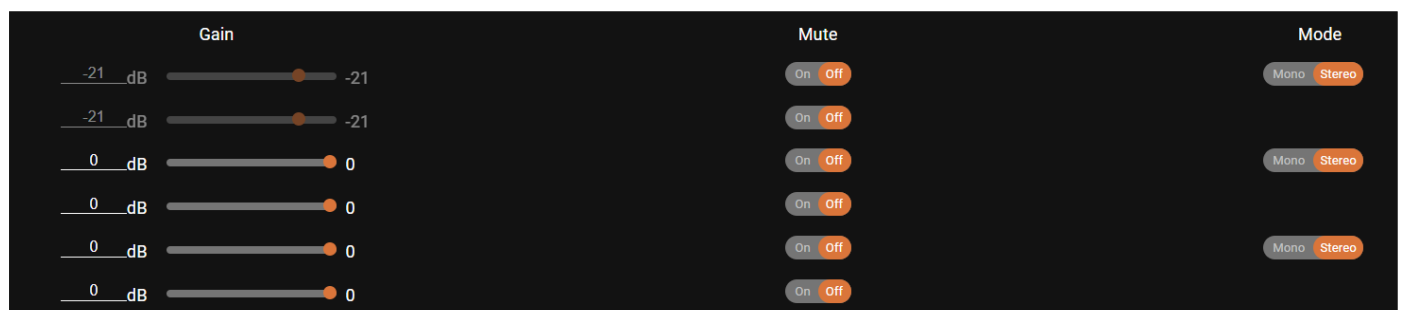

Mute

Each output includes a **Mute** toggle switch that can be set to either **On** or **Off**. When set to **On**, the output is muted, and no audio is sent to the connected speaker or device. When set to **Off**, the output remains active and follows the configured gain setting. The **Mute** toggle functions independently for each output channel and is available in both **Mono** and **Stereo** modes.

Mode

Each output pair includes a **Mode** toggle switch that can be set to either **Mono** or **Stereo**. This setting determines how the output channels behave and how gain and mute settings are applied. In **Mono** mode, the left and right outputs can be adjusted independently. In **Stereo** mode, changes made to one channel—such as adjusting gain or muting—will automatically apply to both channels to maintain consistent stereo output. This allows flexibility for both single-channel and stereo speaker configurations, depending on the needs of the installation.

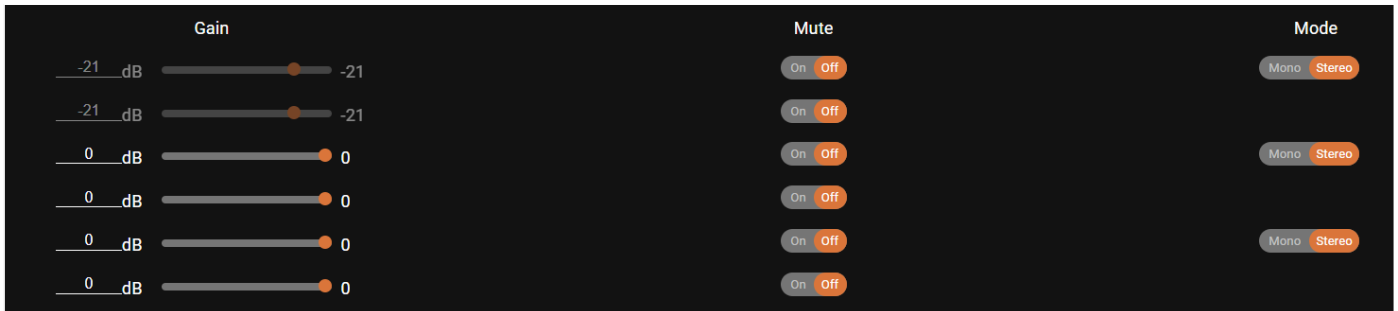

EQ

The **EQ** section provides powerful tools for shaping the tonal balance of the output signal. It includes high-pass and low-pass filters (HPF and LPF) with adjustable frequency points and selectable slope settings, allowing precise control over which frequencies are allowed through. These filters are useful for removing unwanted low-frequency rumble or high-frequency noise, and for tailoring the overall sound to suit specific loudspeakers or acoustic environments. All EQ processing is applied at the output stage, ensuring optimal performance for the final signal.

The definitions and behavior of each EQ setting are consistent across all outputs.

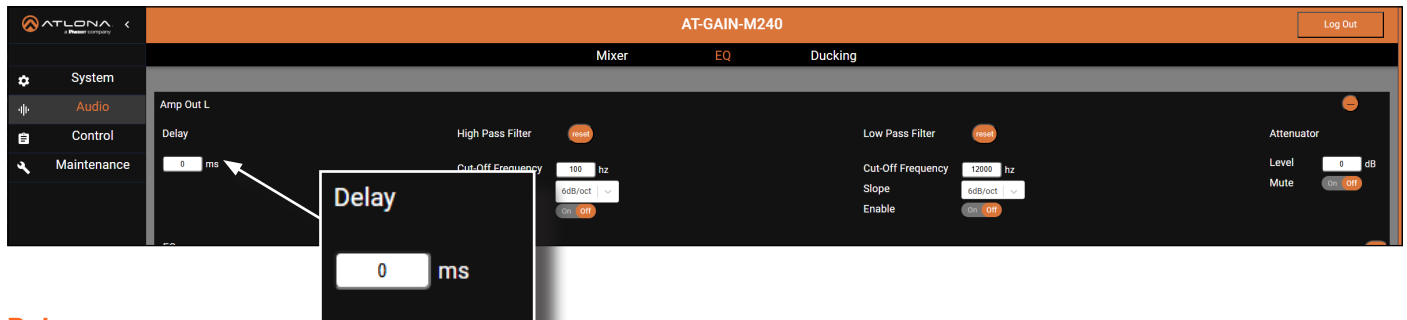

Delay

The delay setting is used to align audio signals that reach different speakers or listener positions at different times. This is especially useful in multi-speaker setups where physical distance between speakers can cause phase issues or echo-like effects. By adding a precise amount of delay to certain outputs, you can synchronize sound arrival times, improving clarity and cohesion in the listening environment. Delay is in milliseconds.

Example 1.1 - Delay

Two speakers, A and B, are positioned on opposite sides of a room, each emitting the same audio signal (a stereo pair). A dog enters and settles down 20 feet from Speaker A and 50 feet from Speaker B. With the speed of sound at 1130 feet per second, it's clear that the sound from Speaker A will reach the dog first. The 30-foot difference in distance between the two speakers creates a timing offset. To correct this and ensure both signals arrive simultaneously, a delay must be applied to Speaker A. Using the information provided, the required delay value can be calculated using the following formula:

$$\text{Delay (ms)} = \text{Distance (ft)} / 1.13$$

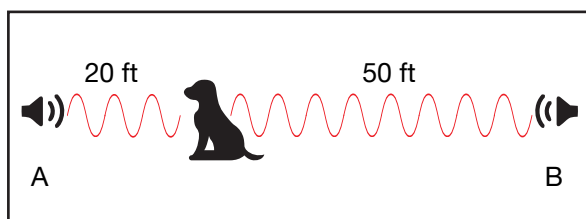

NOTE: The value 1.13 comes from converting 1,130 feet per second to feet per millisecond. Since 1 second = 1,000 milliseconds, $1,130 \div 1,000 = 1.13$ feet per millisecond.

$$\text{Delay (ms)} = 30 / 1.13 = 26.55. \text{ Therefore, the delay for Speaker A would be set to 26 ms.}$$



NOTE: If each speaker were producing a pure 440 Hz sine wave, a 30-foot difference in distance between them would create a phase shift of roughly 245°. A 180° shift would cause complete *destructive interference*—where the waves fully cancel out—but at 245°, the interference is only partial. This partial phase mismatch leads to a noticeable drop in audio clarity at the listener's position, caused by phase-related distortion. The section on the next page briefly covers this subject.

More on Waves and Phase

For those interested in the underlying science, this section provides a closer look at how sound waves interact when arriving at different times. The material is not required for operating the product and is intended as an optional reference. The following illustrations show how signals can reinforce or cancel each other depending on their phase relationship and why small delays or offsets can dramatically affect sound clarity.

In the previous section, adjusting the **Delay** value corrected phase issues caused by the dog's position in a simple two-speaker setup. By moving the dog to different points in the room and reporting the results, the effects of phase can be observed.

Illustration 1.1 represents the sound recorded when the dog is in the middle of the room, exactly the same distance from both speakers. At this position, the signals from Speaker A and Speaker B arrive together, with no delay offset.

- The blue and red lines represent the individual waves from each speaker. Both waves have the same amplitude and phase, so the resulting combined wave is shown in magenta.
- The black line shows the combined result of both of these waves at the dog's position.

Mathematically, given both waves have magnitude A , then their sum is: $A \sin(x) + A \sin(x) = 2 * A \sin(x)$.

Because the waves arrive in sync, they reinforce one another. This is *constructive interference*, and the combined signal has twice the amplitude of the original waves.

Illustration 1.1 - Constructive Interference - Both waves in phase.

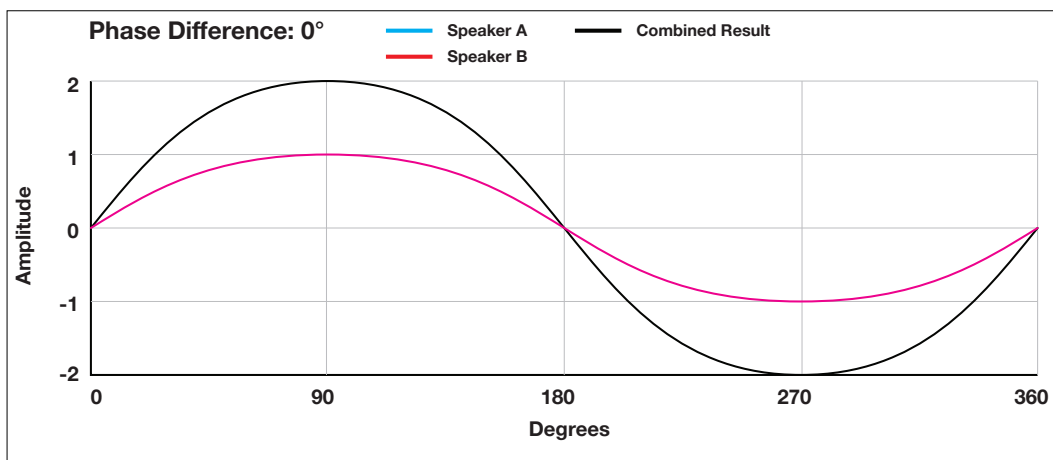

In-phase sum peak amplitude = 2

Increase $\approx +6.02$ dB

Illustration 1.2 on the next page, shows the dog after moving to a new spot in the room and recording the result. At this location, the signals from Speaker A and Speaker B arrive with a 90° phase difference.

- The blue and red lines represent the individual waves from each speaker.
- The black line shows the combined result of those waves at the dog's position.
- The gray dashed line is a reference, showing what the combined result would look like if the signals were perfectly in phase (0°).
- The shaded area represents the energy lost to destructive interference — where the actual combined wave falls short of the ideal in-phase sum.

This outcome is partial destructive interference: the sound is weaker and less clear, with some of the original energy lost. Any phase difference other than 0° (fully constructive) or 180° (fully destructive) produces partial interference. The 90° case illustrates one such situation where cancellation is strong, but not complete silence.

Illustration 1.2 - Partial Destructive Interference - Waves out of phase by 90°

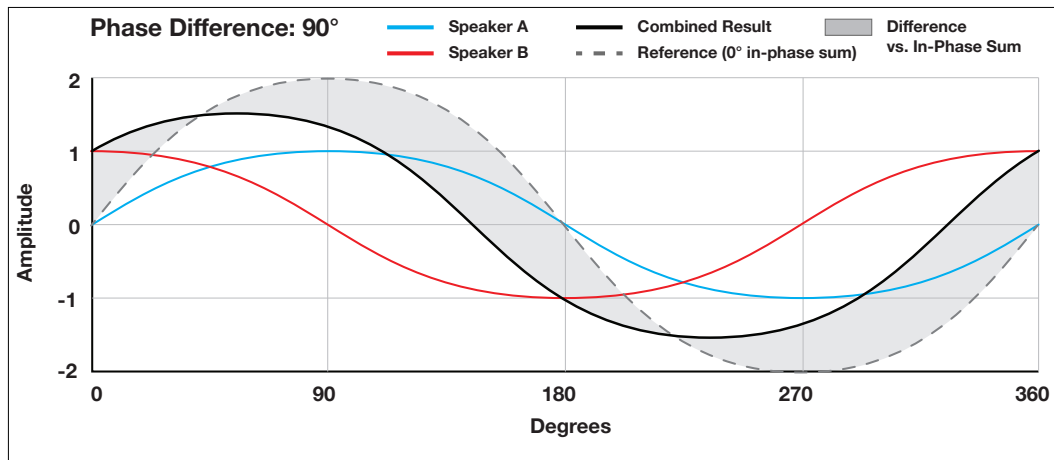

In-phase peak amplitude = 2 90° sum peak = 1.414 Reduction = 0.707 ≈ -3 dB

Finally, in *Illustration 1.3*, the dog shifts to another position in the room. At this location, the signals from Speaker A and Speaker B arrive exactly 180° out of phase.

- The blue and red lines represent the individual waves from each speaker. At this position, they are polar opposites: every peak of one wave aligns with a trough of the other.
- The black line shows the combined result at the dog's position. Here, the line is flat, indicating there is no audible signal. Adding the positive and negative amplitudes of the two waves at each point results in a total of zero — which is exactly what happens to the signal.
- The gray dashed line is the reference — what the combined result would look like if the signals were in phase (0°).
- The shaded areas represent the energy lost to destructive interference. In this case, the shaded regions are much larger, reflecting a complete loss of the signal.

This is complete destructive interference: the peaks of one wave align perfectly with the troughs of the other, and the signals cancel entirely, producing silence at that location.

Illustration 1.3 - Complete Destructive Interference - Waves out of phase by 180°

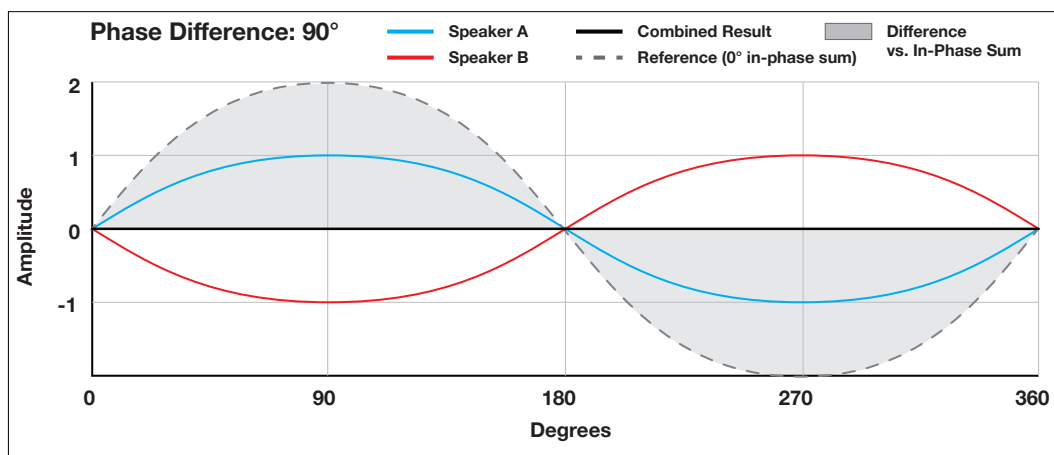

This demonstrates why proper delay alignment is so important—ensuring signals arrive in phase so that clarity and volume are preserved throughout the room.

High Pass Filter

A *high-pass filter* (HPF) allows high-frequency signals to pass through while reducing or eliminating low-frequency content below a specified cutoff point. It's sometimes called a *low-cut filter* because it effectively cuts the lower frequencies. This is useful for removing unwanted low-end noise such as rumble, handling noise, or proximity effect from microphones. In audio systems, applying an HPF helps clean up the mix and improve clarity, especially in speech or vocal applications. The high-pass filter has the following settings.

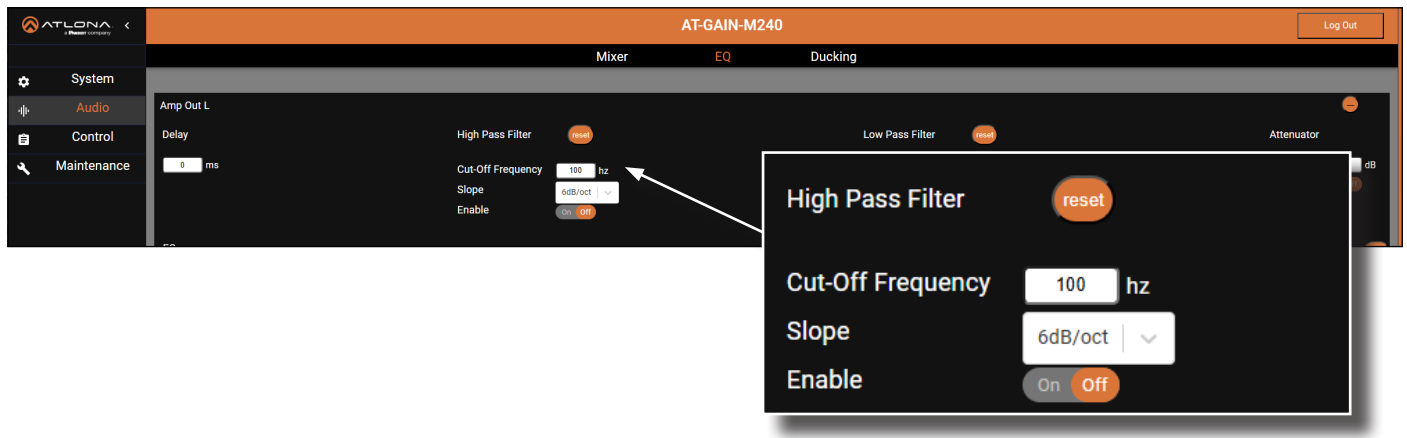

Reset

Click this button to reset the HPF to the default settings. The default HPF settings are:

Parameter	Setting
Cutoff Frequency	100 Hz
Slope	6dB/oct
Enable	Off

Cutoff Frequency

The *cutoff frequency* determines the point at which the filter begins to attenuate *low-end frequencies*. The cutoff frequency is also sometimes referred to as the *cutoff point* or *cutoff*.

Slope

The *slope*, sometimes called the *roll-off*, controls how quickly a filter reduces frequencies beyond the cutoff point. It's measured in decibels per octave (dB/octave). An *octave* is simply a doubling or halving of a frequency. For example, if the cutoff is set at 100 Hz, then one octave below that is 50 Hz. A 12 dB per octave slope means the signal will be reduced by 12 decibels for every octave away from the cutoff. The steeper the slope (like 24 dB/octave), the more quickly those frequencies are reduced. A gentle slope creates a smoother transition, while a steep slope cuts more aggressively, helping you control exactly how much of the signal is filtered out.

Setting	Other terms used in the audio industry
6dB/oct	First-order (1-pole) filter
12dB/oct	Second-order (2-pole) filter
18dB/oct	Third-order (3-pole) filter
24dB/oct	Fourth-order (4-pole) filter
30dB/oct	Fifth-order (5-pole) filter

Enable

Click this toggle to enable (**On**) or disable (**Off**) the HPF. If the Cutoff Frequency is changed to a value other than 100 Hz, then the HPF will automatically be enabled.

The Frequency Spectrum

The illustration below displays the frequency spectrum of an audio signal—a visual representation that shows how much energy (or amplitude) is present at each frequency across the audible range. It’s called a spectrum because it spreads the individual frequency components of the signal across the horizontal axis, from low to high. The horizontal axis represents frequency in Hertz (Hz), ranging from deep bass around 20 Hz to high treble at 20 kHz, the upper limit of human hearing.

The vertical axis shows level in decibels (dB). The 0 dB line is a reference level (unity gain), meaning “no change” relative to that reference. The gray area represents the original, unprocessed audio content, illustrating how sound energy is distributed across the spectrum before any EQ or processing is applied. This view helps visualize the balance of frequencies in a signal.

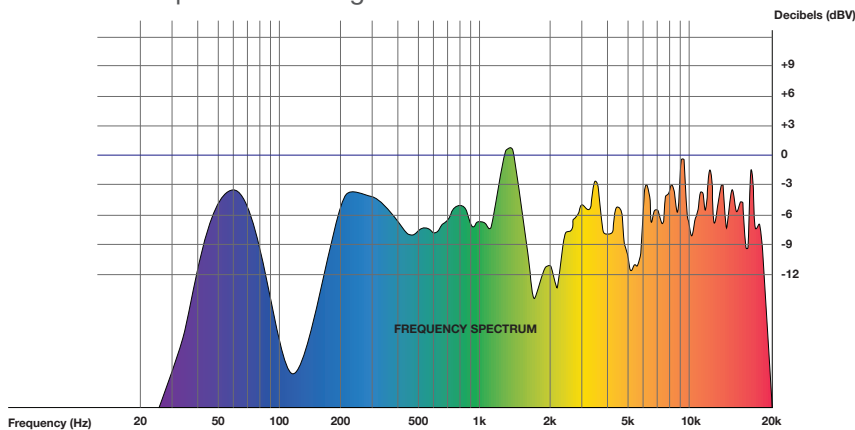

Example 1.2 - High-Pass Filter

This next illustration builds on the previous one by showing how a high-pass filter (HPF) affects an audio signal. The original signal is still visible in light gray, while the blue overlay represents the filtered output. A high-pass filter allows higher frequencies to pass through while reducing the lower frequencies. That’s why the left side of the graph—representing low bass—is diminished, while the higher-frequency content remains largely unchanged.

The filter is set to around 700 Hz. In many audio contexts, the cutoff (or corner) frequency is defined at the point where the level is about reduced by -3 dB. On the graph, this is shown where the filter curve intersects the -3 dB line near 700 Hz. Below that point, the curve continues downward, showing how the filter increasingly reduces lower frequencies. The result is a cleaner frequency range with less low-end rumble or “boominess”.

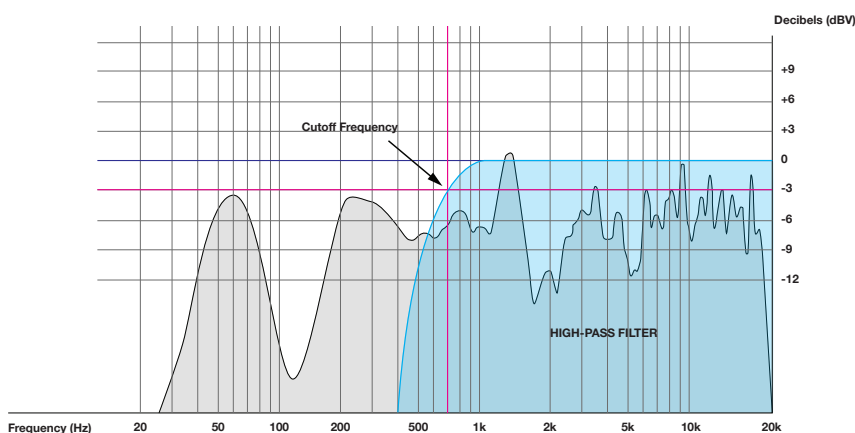

NOTE: Keep in mind that filter slope (roll-off) is not the same as volume level. Although both are measured in decibels, a high-pass filter with a slope of “30 dB per octave” only affects frequencies below the cutoff point—it does not reduce the overall volume of the audio. The rest of the signal remains unaffected; only the lower frequencies are gradually attenuated.

Low Pass Filter

A *low-pass filter* (LPF) works in the opposite way of a high-pass filter. It allows low-frequency signals to pass through while reducing or eliminating high-frequency content above a specified cutoff point. This type of filter is sometimes called a *high-cut filter* because it attenuates the higher frequencies. Low-pass filters are commonly used to reduce harshness, hiss, or other high-end noise, and can help smooth out the sound of certain instruments or recordings. In audio systems, applying an LPF can create a warmer, more controlled tone, especially when working with bass instruments or subwoofer outputs. The low-pass filter has the following settings.



Reset

Click this button to reset the LPF to the default settings. The default LPF settings are:

Parameter	Setting
Cutoff Frequency	12000 Hz
Slope	6dB/oct
Enable	Off

Cutoff Frequency

The *cutoff frequency* is the point at which the filter begins to attenuate high-end frequencies; above this frequency, the signal starts to roll off. The cutoff frequency is also sometimes referred to as the cutoff point, or simply the cutoff.

Slope

The *slope*, sometimes called the *roll-off*, controls how quickly a filter reduces frequencies beyond the cutoff point. It's measured in decibels per octave (dB/octave). An octave is simply a doubling or halving of a frequency. For example, if the cutoff is set at 1,000 Hz, then one octave above that is 2,000 Hz. A 12 dB per octave slope means the signal will be reduced by 12 decibels for every octave away from the cutoff. The steeper the slope (like 24 dB/octave), the more quickly those higher frequencies are reduced. A gentle slope creates a smoother transition, while a steep slope cuts more aggressively—helping control how much high-frequency content is filtered out.

Setting	Other terms used in the audio industry
6dB/oct	First-order (1-pole) filter
12dB/oct	Second-order (2-pole) filter
18dB/oct	Third-order (3-pole) filter
24dB/oct	Fourth-order (4-pole) filter
30dB/oct	Fifth-order (5-pole) filter

Enable

Click this toggle to enable (**On**) or disable (**Off**) the LPF. If the Cutoff Frequency is changed to a value other than 12000 Hz, then the LPF will automatically be enabled.

Example 1.3 - Low-Pass Filter

This graph shows how a low-pass filter (LPF) affects an audio signal. The original, unfiltered signal is shown in light gray, while the pink overlay represents the signal after the LPF is applied. A low-pass filter allows low-frequency content to pass through while attenuating higher frequencies beyond a certain point.

In this case, the filter's cutoff frequency is about 600 Hz, which is where the pink curve begins to slope downward. As with the high-pass filter, the cutoff (or corner) frequency is defined at the point where the level is about 3 dB down from the passband. This is the point where the LPF starts reducing the level of high-frequency content. The slope of the filter—approximately 30 dB per octave—determines how sharply those high frequencies are rolled off. Frequencies below the cutoff remain largely untouched, preserving the body and warmth of the original signal.

The LPF is useful for reducing harshness or hiss, shaping the tonal balance of instruments, or cleaning up high-frequency clutter in a mix. It's also frequently used when routing audio to subwoofers or isolating low-end elements in a sound system.

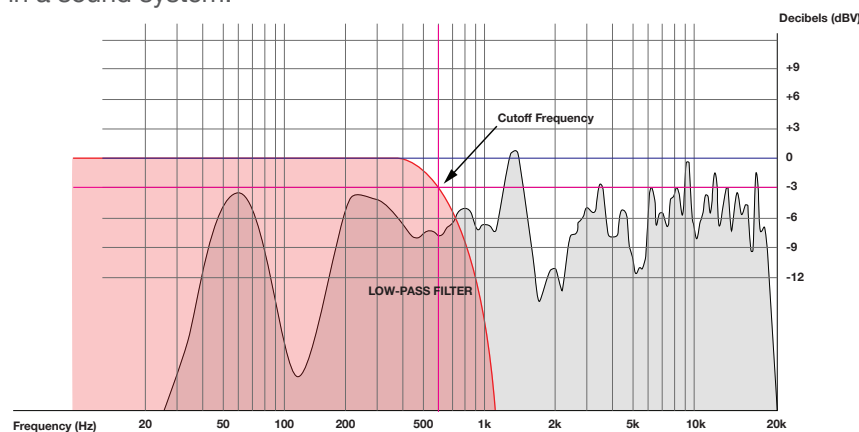

More on Filter Slope / Roll-Off Rate

The slope of a filter determines how sharply frequencies are reduced beyond the cutoff point. A gentle slope like 6 or 12 dB per octave results in a smoother, more gradual transition, which can preserve natural tone or avoid making the audio sound too “cut off.” A steeper slope, like 24 or 30 dB per octave, creates a more aggressive filter, quickly removing unwanted frequencies—but sometimes at the cost of musicality or warmth. The right slope depends on the situation. For subtle cleanup, a gentle roll-off may be ideal. For precise control—like removing mic rumble or isolating a subwoofer signal—a steeper slope might be more effective.

Some audio systems even allow for a slope of infinity dB per octave, sometimes called a *brick-wall filter* or *wall filter*. This type of filter cuts off all frequencies beyond the cutoff point with no gradual slope—like dropping off a cliff. While the AT-GAIN-M120 / M240 doesn't support this level of filtering, it's helpful to understand how extreme filters work and why most systems prefer smoother slopes that sound more natural to the ear.

Example 1.4 - Brick-Wall High-Pass Filter

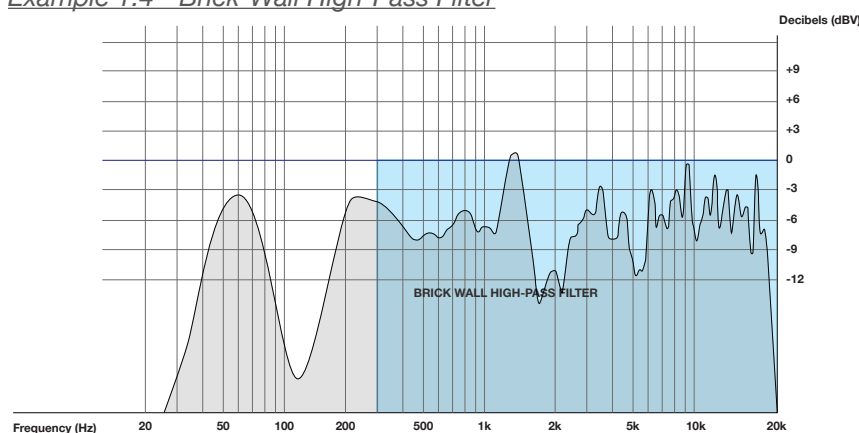

Band-pass Filters

A *band-pass* filter passes a selected range (“band”) of frequencies while attenuating frequencies below and above that range. One common way to create a band-pass filter is to combine a high-pass filter (HPF) with a low-pass filter (LPF): the HPF sets the lower cutoff frequency, and the LPF sets the upper cutoff frequency. Band-pass filters are often used to isolate instruments, reduce unwanted noise outside a target frequency range, or shape tonal balance in music production, live sound, and broadcast applications.

Example 1.5 - Band-pass Filter

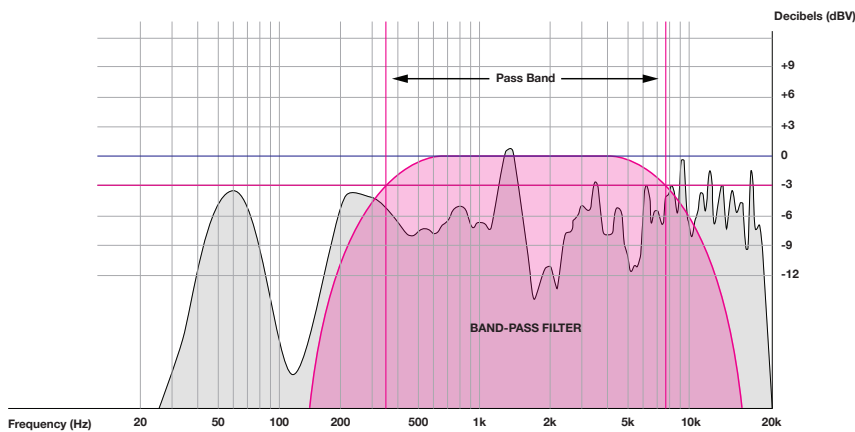

Attenuator

The *attenuator* setting reduces the amplitude (or volume) of an audio signal without distorting its waveform. It’s commonly used to lower signal levels before they reach the next stage in the signal chain—such as an amplifier, mixer, or recording device—in order to prevent distortion, protect equipment, and ensure proper level matching between components. The AT-GAIN-M120 / M240 offers a variable attenuator, allowing precise manual control.

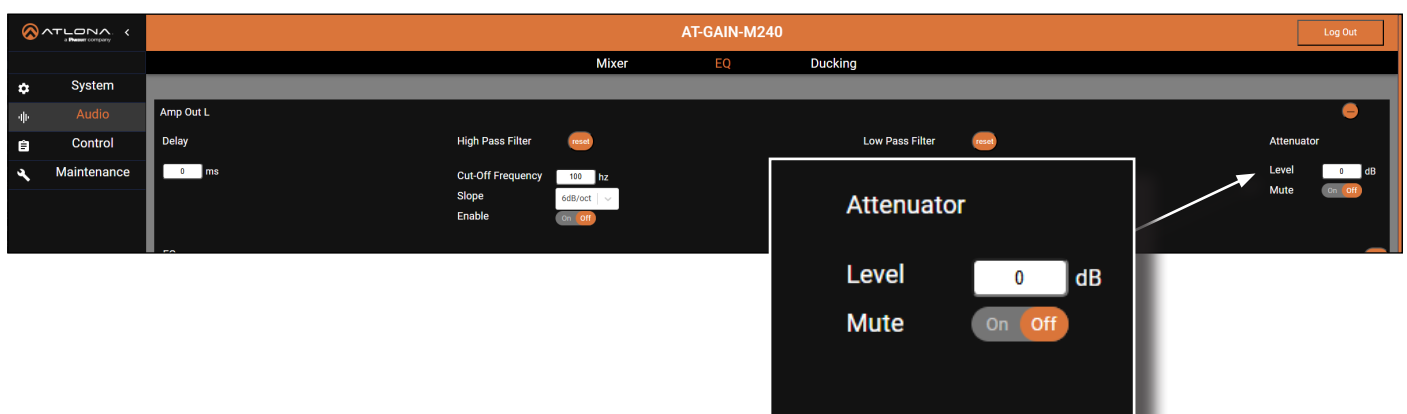

Level

Enter the desired attenuation amount in this field. The value should be specified in dBV.

Mute

This toggle switch allows you to instantly silence the audio signal passing through the attenuator. When set to **On**, the signal is muted; when set to **Off**, normal signal flow resumes. This is useful for quickly disabling audio without changing the attenuation level.

EQ

The EQ (equalizer) section features a flexible 5-band parametric equalizer designed for precise tone shaping and signal control. Each of the five bands can be individually enabled or disabled using dedicated toggle switches, allowing for custom configurations tailored to specific audio needs. For each active band, the center frequency, Q (bandwidth), and gain can be adjusted to fine-tune the signal. These settings provide the tools necessary to sculpt audio with accuracy and clarity. The following sections offer a closer look at each control and its impact on overall EQ performance.

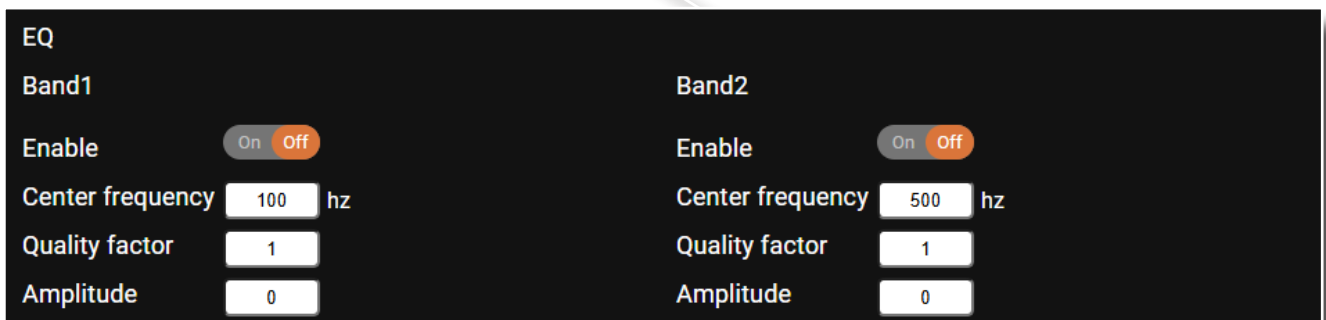
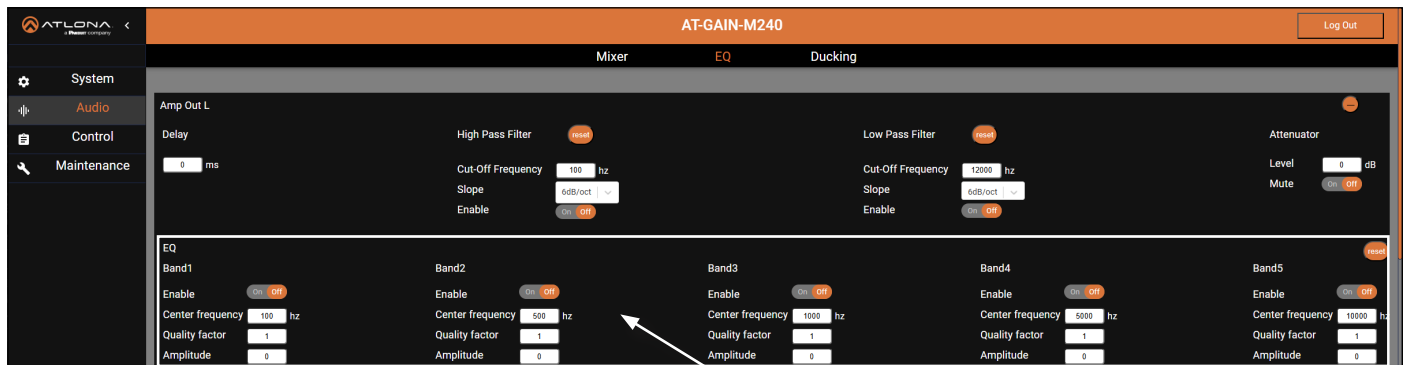

Enable

The **Enable** toggle switch allows each EQ band to be individually activated or bypassed. When set to **On**, the band is active and its **Center frequency**, **Q**, and **Amplitude** settings are applied to the audio signal. When set to **Off**, the band is bypassed, and no EQ adjustments from that band affect the signal. This feature provides flexible control over the equalizer, making it easy to engage only the bands needed for a particular application without altering other settings.

Center Frequency

The **Center frequency** field sets the specific frequency at the midpoint of the EQ band's effect. This is the frequency around which the band will apply boost or cut, depending on the amplitude setting. Selecting an appropriate center frequency allows targeted adjustments—such as reducing muddiness in the low mids or enhancing clarity in the upper range. Each EQ band operates independently, so different center frequencies can be set across all five bands for detailed and precise tonal shaping.

Quality factor

The **Quality factor** (or simply “Q”) controls the bandwidth of the EQ band, determining how wide or narrow the frequency range is around the selected center frequency. In EQ applications, a higher Q value results in a narrower bandwidth, affecting a smaller range of frequencies—ideal for surgical adjustments or removing specific tones. A lower Q value produces a wider bandwidth, impacting a broader portion of the frequency spectrum for more general tonal shaping. Adjusting the Q value allows for precise control over how focused or broad each EQ band's effect will be.

Amplitude

The **Amplitude** field sets the amount of boost or cut applied to the selected frequency band. Positive values increase the level of the band (boost), while negative values decrease it (cut). This control determines how much influence the EQ band has on the overall signal, allowing for subtle tonal adjustments or more pronounced shaping. Combined with the center frequency and Q settings, the amplitude field provides fine control over the EQ curve, helping to enhance or correct specific elements within the audio signal.

Example 1.6 - Corrective EQ

While equalization is often used to enhance sound—shaping bass, treble, and overall tone to suit a room or preference—it also serves a critical role in correcting audio issues. *Corrective EQ* focuses on identifying and reducing unwanted frequencies caused by problems like electrical interference, mechanical rumble, or room artifacts. A common technique involves temporarily boosting a single EQ band and sweeping the center frequency to locate the issue, then reducing the amplitude and adjusting the Q to precisely cut the problematic range. Even without a spectrum analyzer, this method can effectively clean up the signal through careful listening and subtle adjustments.

In the following example, an unwanted low-frequency “hum” (shaded region) is present in the audio signal—a common issue in many sound systems. This type of hum is often caused by unbalanced signal lines, improper grounding (typically resulting in a 60 Hz hum in North America or 50 Hz in other regions), or mechanical vibrations picked up by microphone stands, such as stage rumble or HVAC noise. With proper use of EQ, this hum can be significantly reduced or even completely removed.

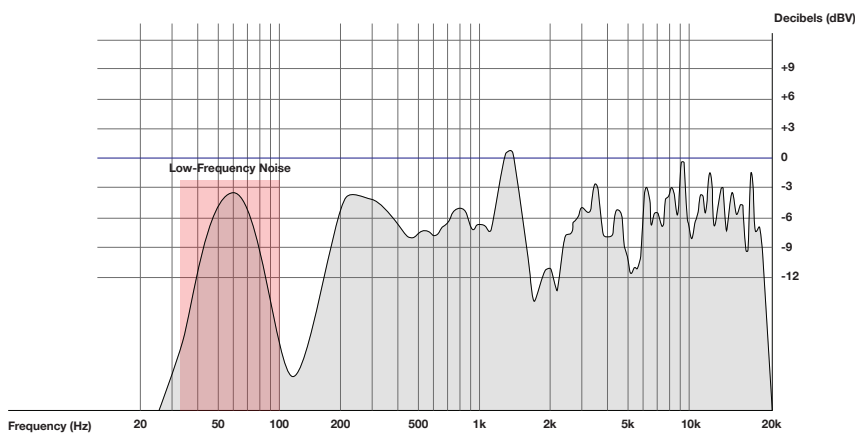

1. Select one of the five EQ bands and toggle the **Enable** switch to **On**. Since this is low-frequency hum, this example will use the settings for **Band1**. However, any of the five bands could be adjusted.

EQ		EQ	
Band1		Band2	
Enable	<input checked="" type="checkbox"/> On <input type="checkbox"/> Off	Enable	<input checked="" type="checkbox"/> On <input type="checkbox"/> Off
Center frequency	<input type="text" value="60"/> hz	Center frequency	<input type="text" value="500"/> hz
Quality factor	<input type="text" value="1"/>	Quality factor	<input type="text" value="1"/>
Amplitude	<input type="text" value="0"/>	Amplitude	<input type="text" value="0"/>

2. In the **Center frequency** field, enter a starting value within the problematic range—60 Hz is a good initial target, especially if the hum is related to electrical grounding or line noise.

- Increase the **Amplitude** slightly by entering a value of 7 to temporarily boost the selected frequency. Listen for a noticeable increase in the hum, confirming that the correct frequency has been targeted.

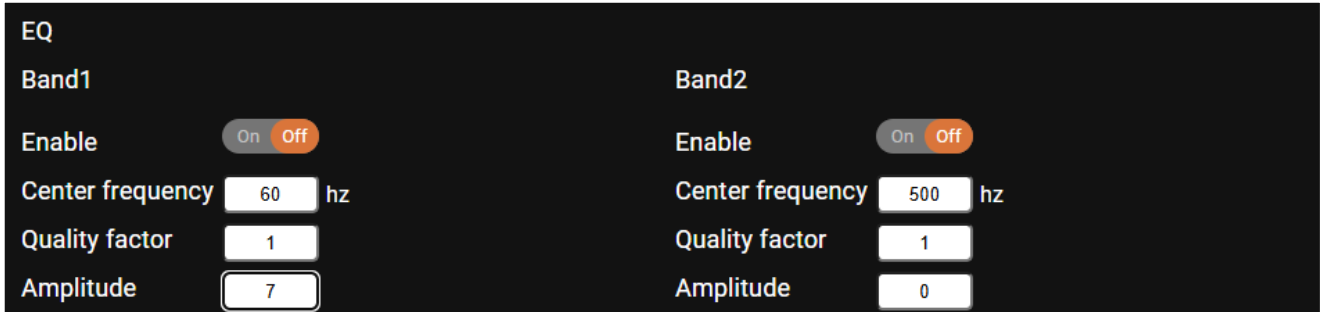

The illustration shows a single EQ band centered at 60 Hz, with a **Quality factor** of 1 and an amplitude boost of +7 dB, represented by the red EQ curve. This setup helps identify unwanted low-frequency hum—often caused by unbalanced lines or grounding issues. By gradually adjusting (“sweeping”) the center frequency across the frequency spectrum, the hum becomes more pronounced when the band aligns with the problem area.

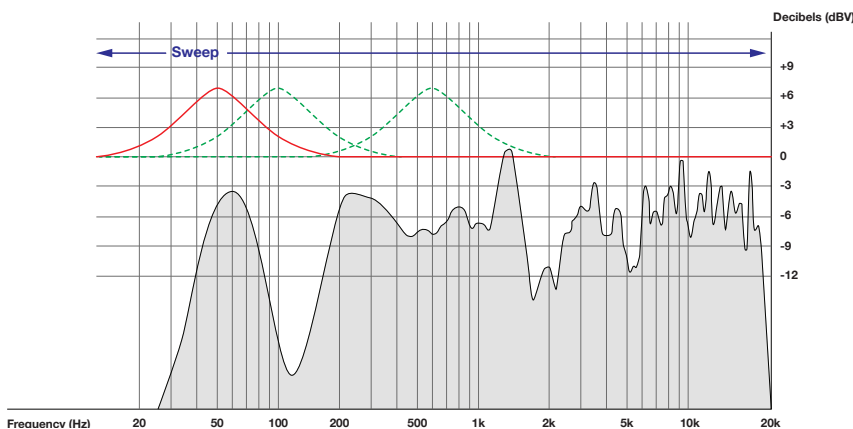

- Set the **Quality factor** value to a moderately high setting (e.g., 5.0) to create a narrow bandwidth, isolating the hum without impacting nearby frequencies. In the example shown below, the **Quality factor** value was increased to 10 (red line) which targeted where the hum was strongest. Additional Q values are also shown on the graph for comparison, illustrating how different bandwidth settings affect the range of frequencies impacted by the EQ band.

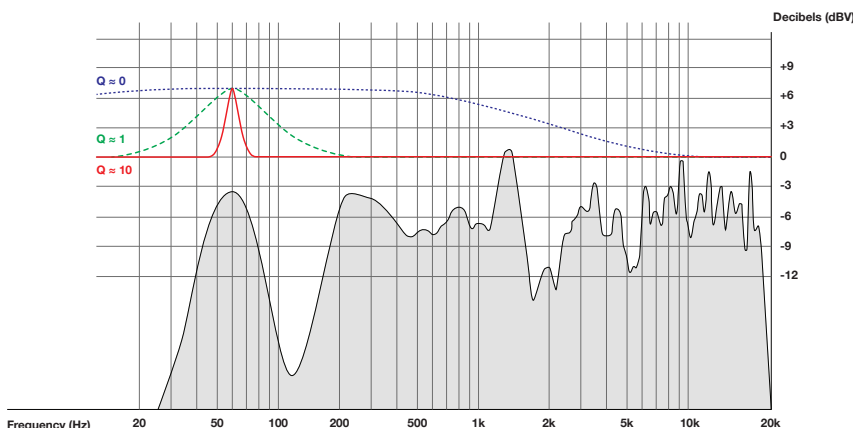

- Once the hum is isolated, reduce the **Amplitude** field to a negative value (e.g., -6 dB or more) to attenuate the unwanted frequency. In the example below, the **Amplitude** field was set to approximately -11 dB.

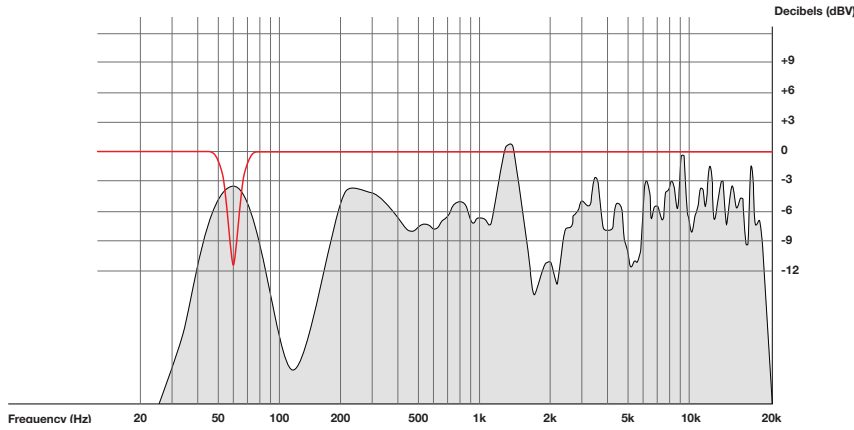

- Widen or narrow the **Q** to control how much of the surrounding frequency range is affected. Use the narrowest setting that effectively removes the hum without thinning the overall sound.

Ducking

Ducking is a dynamic audio processing technique that automatically lowers the level of one signal when another signal is present. It's commonly used to ensure that a primary sound—such as a voice—remains clear and intelligible when other sounds are playing. For example, in a live or broadcast setting, ducking can lower the volume of background music whenever someone speaks into a microphone. This effect is triggered by a separate audio source, known as the sidechain, which tells the processor when to reduce the level of the target signal. Ducking is especially useful for voiceovers, public address systems, podcasts, and mixing environments where clarity and priority are essential.

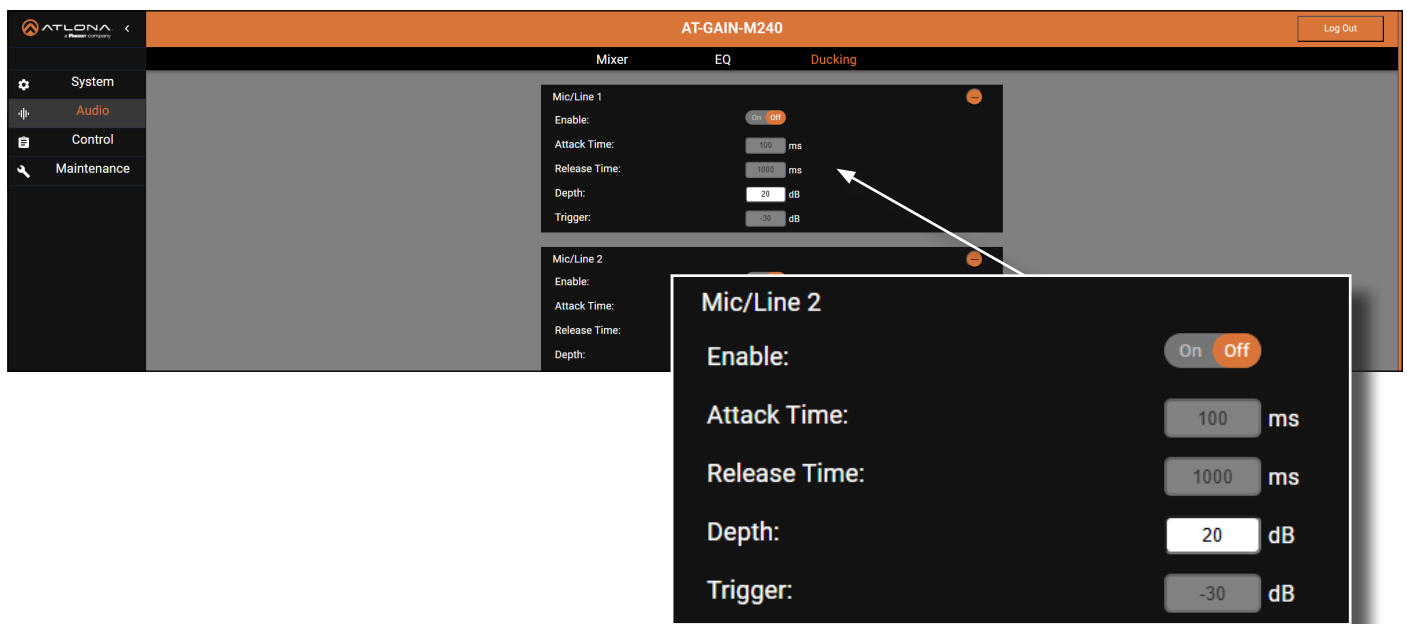

The AT-GAIN-M120 / M240 features four **Mic/Line** inputs (**Mic/Line1** – **Mic/Line4**), each with identical ducking controls: **Enable** (on/off toggle), **Attack Time**, **Release Time**, **Depth**, and **Trigger**. The **Depth** setting can only be adjusted when the corresponding **Mic/Line** input is disabled (**Off**), allowing the desired level of attenuation to be set prior to activating the ducking function.

In the illustration below, two audio channels are shown: voice and background audio. In the background audio channel, the region in purple, between 00:00:15 and approximately 00:00:22, represents the period during which ducking occurs—that is, when voice audio is present. At 00:00:15, the background audio is automatically lowered to the level shown in the orange-shaded area. This reduction is achieved using a technique called *sidechain compression*, where the signal from one audio channel (the voice) triggers a compressor to control the volume of another channel (the background audio).

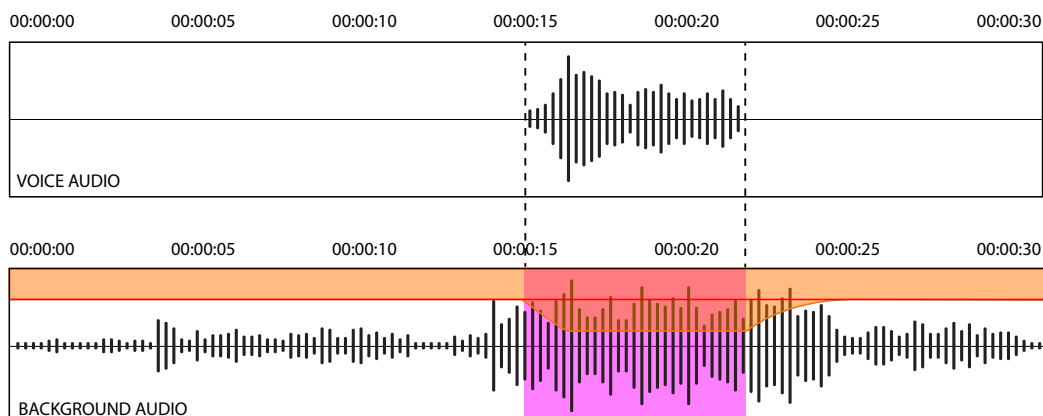

Enable

Activates or deactivates the ducking function for the selected **Mic/Line** input. When set to **On**, the input can trigger ducking based on its signal level and the defined parameters. When set to **Off**, ducking is disabled for that input. **Depth** is the only ducking parameter that can be adjusted while the input is disabled, allowing the desired attenuation level to be set in advance before enabling ducking.

Attack Time

Controls how quickly the background audio is reduced after the trigger signal (e.g., voice) is detected. Measured in milliseconds (ms), this setting determines the speed at which ducking engages. A shorter attack time results in a faster response, causing the background audio to drop almost immediately. A longer attack time creates a more gradual fade, which can sound more natural in certain applications. Adjusting this setting helps balance clarity and smoothness in the transition.

Release Time

Determines how quickly the background audio returns to its original level after the trigger signal (e.g., voice) stops. Measured in milliseconds (ms), this setting controls the speed at which ducking disengages. A shorter release time causes the background audio to rise back quickly, which can be useful for tight, responsive transitions. A longer release time results in a smoother, more gradual return, helping to avoid abrupt volume changes and maintain a polished sound during pauses or between phrases.

Depth

Sets the amount of volume reduction, measured in decibels (dB), applied to the background audio when ducking is active. This determines how far the signal is attenuated while the trigger input (e.g., voice) is present. A higher depth value results in a more noticeable drop in background audio, making the primary signal more prominent. A lower Depth value applies a gentler reduction, allowing the background audio to remain partially audible. Depth is the only ducking parameter that can be adjusted while the input is disabled, allowing the desired attenuation level to be set before enabling ducking.

Trigger

Defines the audio level, measured in decibels (dB), at which ducking is activated. When the input signal (e.g., voice) exceeds this threshold, ducking engages and reduces the background audio according to the set parameters. A lower trigger value makes ducking more sensitive, activating with softer input levels, while a higher value requires a louder signal to initiate ducking. Adjusting the trigger helps fine-tune when ducking should occur based on the dynamics of the incoming audio.

Configuration and Management Interfaces

Web Server

The AT-GAIN-M120 / M240 includes a built-in web server. Atlona recommends that the web server be used to set up the AT-GAIN-M120 / M240, as it provides intuitive management of all features. Refer to [Logging in after Registration \(page 35\)](#) for more information.

The AT-GAIN-M120 / M240 is shipped with DHCP enabled. Once connected to a network, the DHCP server will automatically assign an IP address to the unit. Use an IP scanner to determine the IP address of the AT-GAIN-M120 / M240. If a DHCP server cannot be located within 15 seconds, the AT-GAIN-M120 / M240 will be placed in [Automatic Private IP Addressing \(APIPA\) Mode \(page 18\)](#). If a static IP address is desired, refer to [IP Configuration \(page 17\)](#).

Login

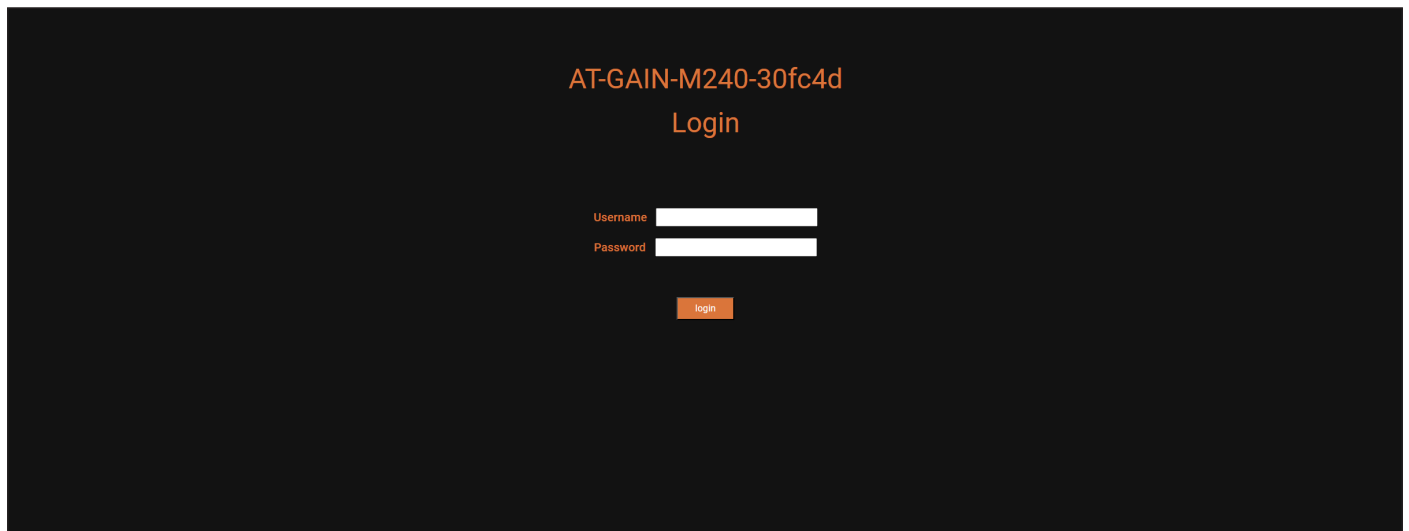

Username

Enter the username in this field. The default value is `admin`.

Password

Enter the password in this field. The default value is `Atlona`.

Login

Click this button to log in.

System > Info

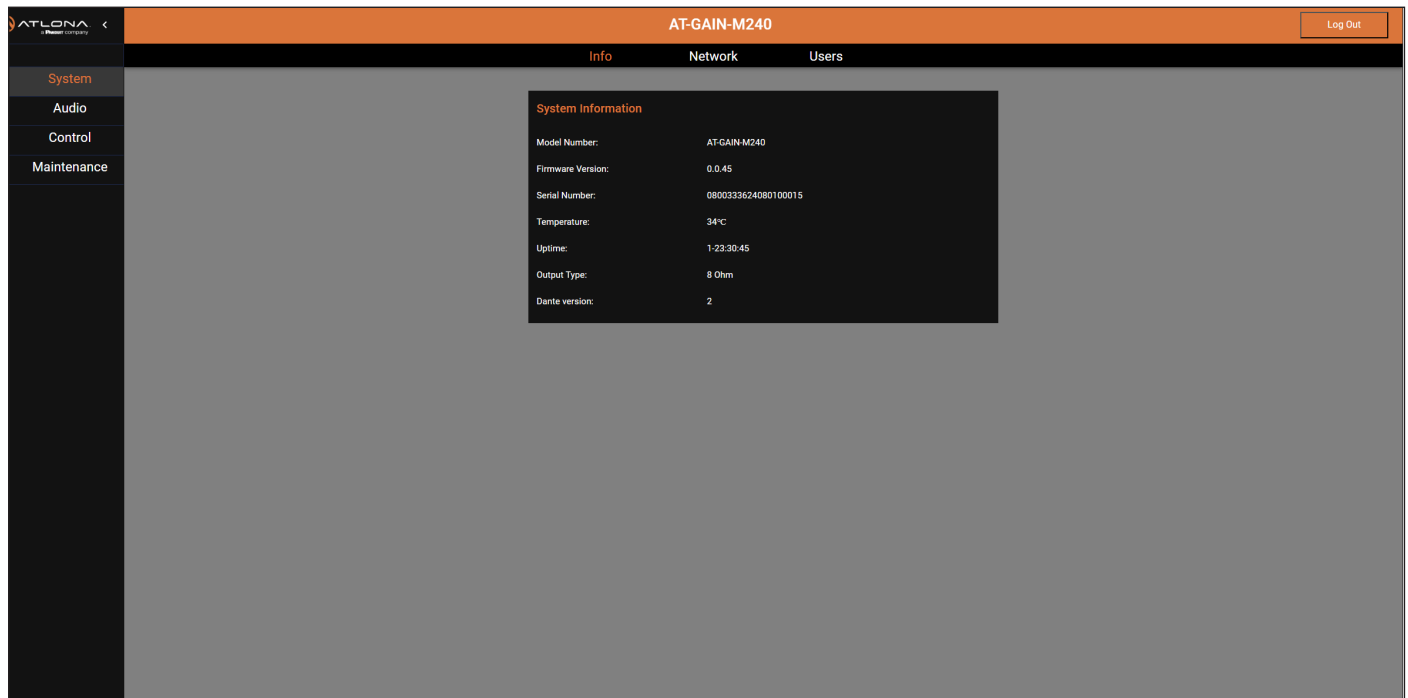

The screenshot shows the AT-GAIN-M240 configuration interface. The top navigation bar includes 'Info', 'Network', and 'Users'. The 'Info' tab is active, displaying a 'System Information' table with the following data:

System Information	
Model Number:	AT-GAIN-M240
Firmware Version:	0.0.45
Serial Number:	0800333624080100015
Temperature:	34°C
Uptime:	1-23:30:45
Output Type:	8 Ohm
Dante version:	2

System Info

Model Name

The model number of this product.

Firmware Version

The version of firmware that the AT-GAIN-M120 / M240 is running. Always make sure to check the AT-GAIN-M120 / M240 product page, on the Atlona web site, for the latest version of firmware.

Serial Number

The product serial number.

Temperature

Displays the internal temperature, in Celsius, of the AT-GAIN-M120 / M240.

Uptime

The length of time that the unit has been powered on. Format is in DD-HH:MM:SS.

Output Type

Indicates the output type. Stereo speaker impedance is specified as either 4 Ohm or 8 Ohm. Mono speakers are specified as 70 V or 100 V.

Dante Version

Displays the version of the Dante® firmware currently installed on the device. This information appears only when a Dante card is installed.

Configuration and Management Interfaces

System > Network

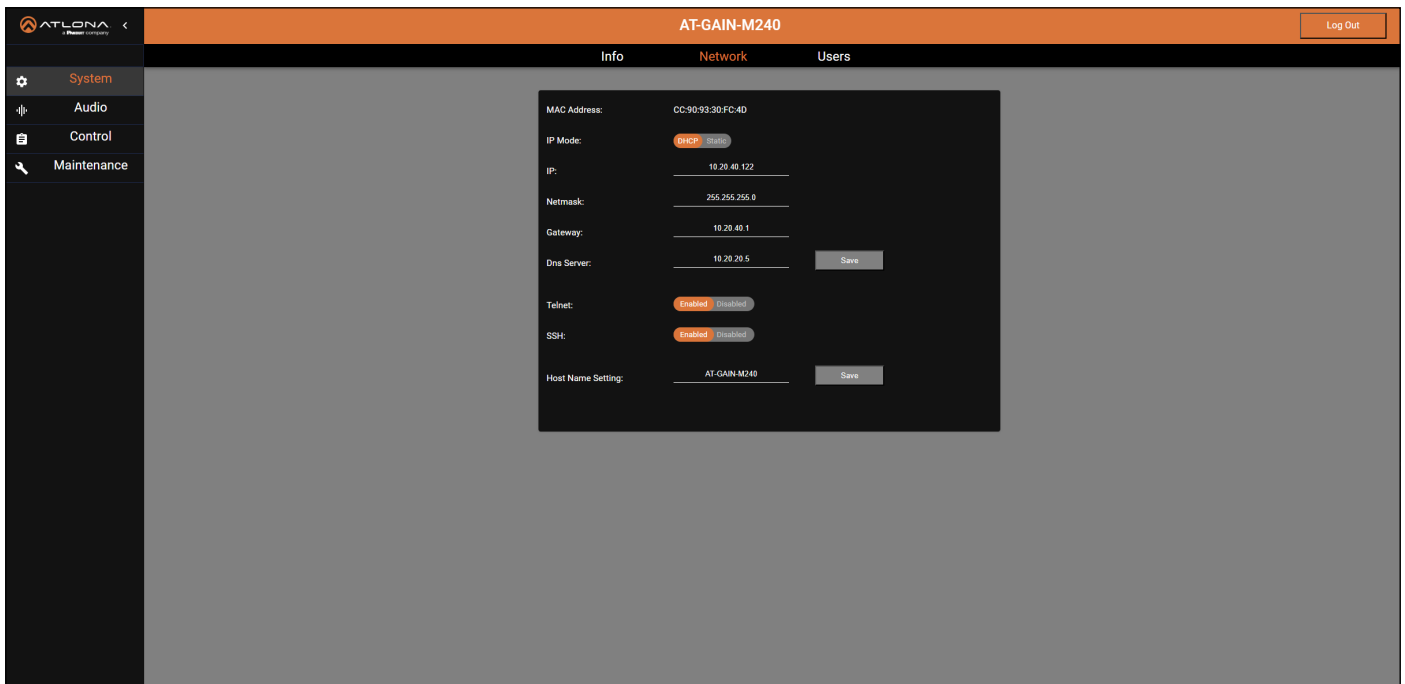

Network

MAC address

Displays the MAC address of the AT-GAIN-M120 / M240.

IP Mode

Click this toggle to set the IP mode of the AT-GAIN-M120 / M240.

Setting	Description
DHCP	Uses an available DHCP server to assign an IP address.
Static	Allows the IP address, subnet mask, and gateway IP address to be entered manually.

IP

Enter the IP address of the AT-GAIN-M120 / M240 in this field. This field will only be available if **IP Mode** is set to *Static*.

Netmask

Enter the subnet mask in this field. This field will only be available if **IP Mode** is set to *Static*.

Gateway

Enter the gateway (router) address in this field. This field will only be available if **IP Mode** is set to *Static*.

Dns Server

Enter the DNS address in this field. This address is used to specify the Domain Name System (DNS) server that the device will use to resolve domain names into IP addresses.

Save

Click this button to commit changes to the **IP**, **Netmask**, **Gateway**, and **Dns Server** fields.

Configuration and Management Interfaces

Telnet

Click this toggle switch to enable or disable Telnet. If disabled, then traffic on port 23 is forbidden.

SSH

Click this toggle switch to enable or disable SSH. If disabled, then traffic on port 22 is forbidden.

Hostname Setting

Enter the desired hostname in this field.

Save

Click this button to commit changes to the **Hostname Setting** field.

System > Users

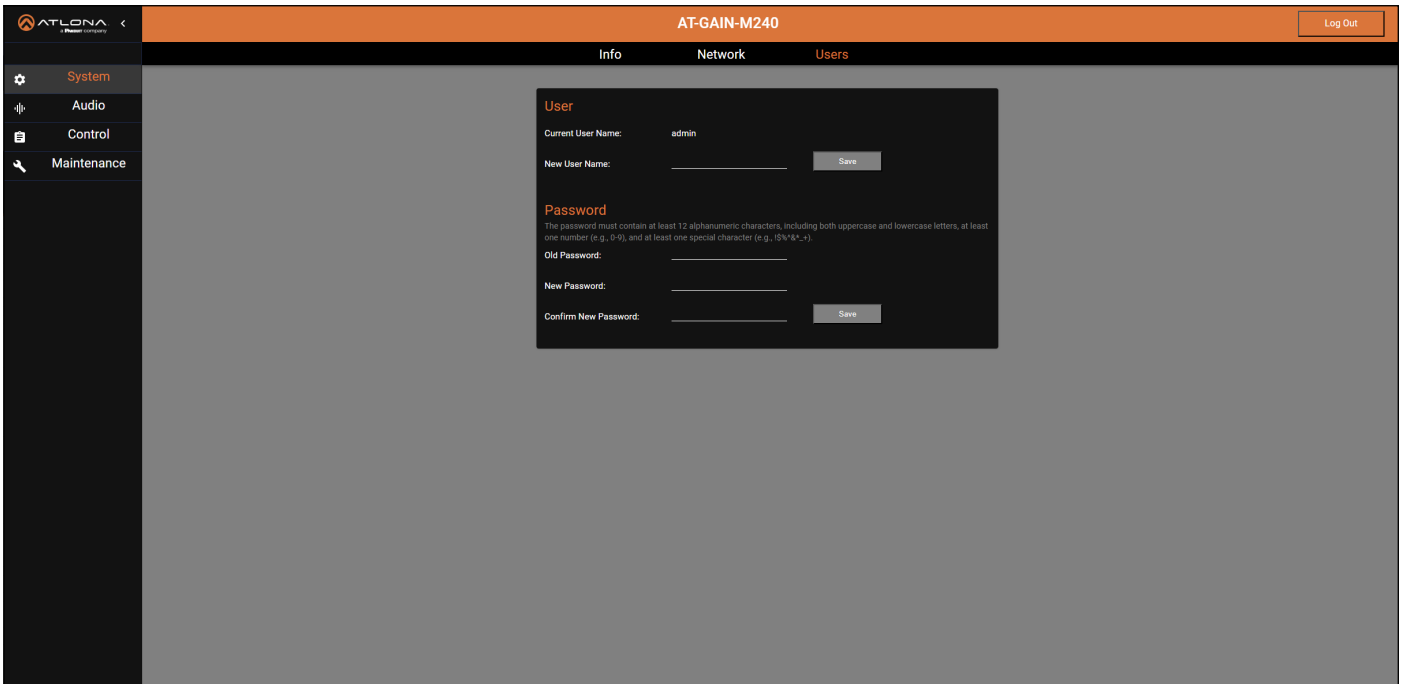

The screenshot shows the AT-GAIN-M240 web interface. The top navigation bar includes the ATLONA logo, the device model 'AT-GAIN-M240', and a 'Log Out' button. Below the navigation bar are tabs for 'Info', 'Network', and 'Users'. The 'Users' tab is active, displaying a 'User' configuration form. The form includes the following fields and buttons:

- Current User Name:** admin
- New User Name:** [text input field] [Save button]
- Password:** [text input field]
- Old Password:** [text input field]
- New Password:** [text input field]
- Confirm New Password:** [text input field] [Save button]

A password requirement note is visible: "The password must contain at least 12 alphanumeric characters, including both uppercase and lowercase letters, at least one number (e.g., 0-9), and at least one special character (e.g., !\$%^&*+_)." The sidebar on the left contains menu items: System, Audio, Control, and Maintenance.

User

Current User Name

Displays the current username.

New User Name

Enter the new username in this field, then click the **Save** button.

Save

Click this button to commit changes to the **New User Name** field.

Password

Passwords must be at least 12 characters long and include a combination of uppercase and lowercase letters, at least one number (0-9), and at least one special character (e.g., !\$%^&*+_).

Old Password

Displays the current username.

New Password

Enter the new username in this field.

Confirm New Password

Verify the new password by entering it in this field, then click the **Save** button.

Save

Click this button to commit changes to all fields in the **Password** section.

Configuration and Management Interfaces

Audio > EQ

The **EQ** section offers robust tools for adjusting the tonal balance of the output signal. It features high-pass and low-pass filters (HPF and LPF) with user-selectable frequency points and slope settings, enabling precise control over the frequency range passed to the output. Each output—such as Amp Out L, Amp Out R, and others—includes identical adjustable parameters. Refer to [EQ \(page 28\)](#) for more information.

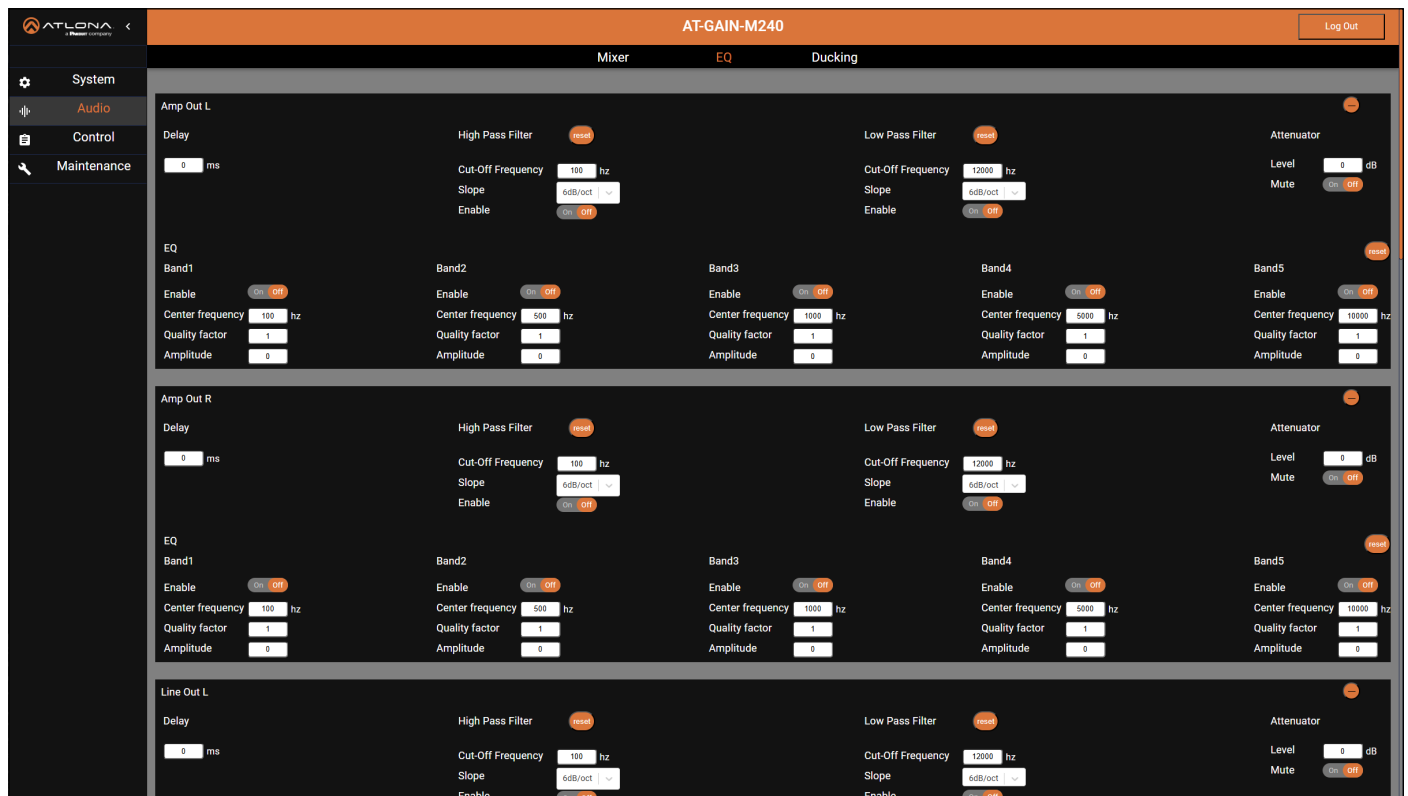

Delay

The delay setting is used to align audio signals that reach different speakers or listener positions at different times. Delay is in milliseconds.

High Pass Filter

High Pass Filter

A *high-pass filter* (HPF) allows high-frequency signals to pass through while reducing or eliminating low-frequency content below a specified cutoff point. Click the **reset** button to restore the filter to its default settings.

Cut-Off Frequency

The *cutoff frequency* determines the point at which the filter begins to attenuate *low-end frequencies*. The cutoff frequency is also referred to as the *cutoff point* or *cutoff*.

Slope

The *slope*, sometimes called the *roll-off*, controls how quickly a filter reduces frequencies beyond the cutoff point. It's measured in decibels per octave (dB/octave). The following values are available.

Slope
6dB/oct
12dB/oct
18dB/oct
24dB/oct
30dB/oct

Enable

Click this toggle to enable (**On**) or disable (**Off**) the HPF. If the **Cutoff Frequency** is changed to a value other than 100 Hz, then the HPF will automatically be enabled.

Configuration and Management Interfaces

Low Pass Filter

Low Pass Filter

A *low-pass filter* (LPF) allows low-frequency signals to pass through while reducing or eliminating high-frequency content below a specified cutoff point. Click the **reset** button to restore the filter to its default settings.

Cut-Off Frequency

The *cutoff frequency* determines the point at which the filter begins to attenuate *high-end frequencies*. The cutoff frequency is also referred to as the *cutoff point* or *cutoff*.

Slope

The *slope*, sometimes called the *roll-off*, controls how quickly a filter reduces frequencies beyond the cutoff point. It's measured in decibels per octave (dB/octave). The following values are available.

Enable

Click this toggle to enable (**On**) or disable (**Off**) the HPF. If the **Cutoff Frequency** is changed to a value other than 12000 Hz, then the LPF will automatically be enabled.

Attenuator

The *attenuator* setting reduces the amplitude (or volume) of an audio signal without distorting its waveform.

Level

Enter the desired attenuation amount in this field. The value should be specified in dBV.

Mute

This toggle switch allows you to instantly silence the audio signal passing through the attenuator. When set to **On**, the signal is muted; when set to **Off**, normal signal flow resumes. This is useful for quickly disabling audio without changing the attenuation level.

Band (1 - 5)

Enable

This toggle switch allows each EQ band to be individually activated or bypassed. When set to **On**, the band is active and its **Center frequency**, **Q**, and **Amplitude** settings are applied to the audio signal. When set to **Off**, the band is bypassed, and no EQ adjustments from that band affect the signal.

Center Frequency

This field sets the specific frequency at the midpoint of the EQ band's effect. This is the frequency around which the band will apply boost or cut, depending on the amplitude setting.

Q

This field controls the bandwidth of the EQ band, determining how wide or narrow the frequency range is around the selected center frequency. Q stands for "quality factor," a term originally used in electronics to describe how selective a filter is.

Amplitude

This field sets the amount of boost or cut applied to the selected frequency band. Positive values increase (boost) the level of the band, while negative values decrease (cut) it.

Configuration and Management Interfaces

Audio > Ducking

Ducking is a dynamic audio processing technique that automatically lowers the level of one signal when another signal is present. Each input—such as Mic/Line 1, Mic/Line 2, and others—includes identical adjustable parameters. Refer to [Ducking \(page 40\)](#) for more information.

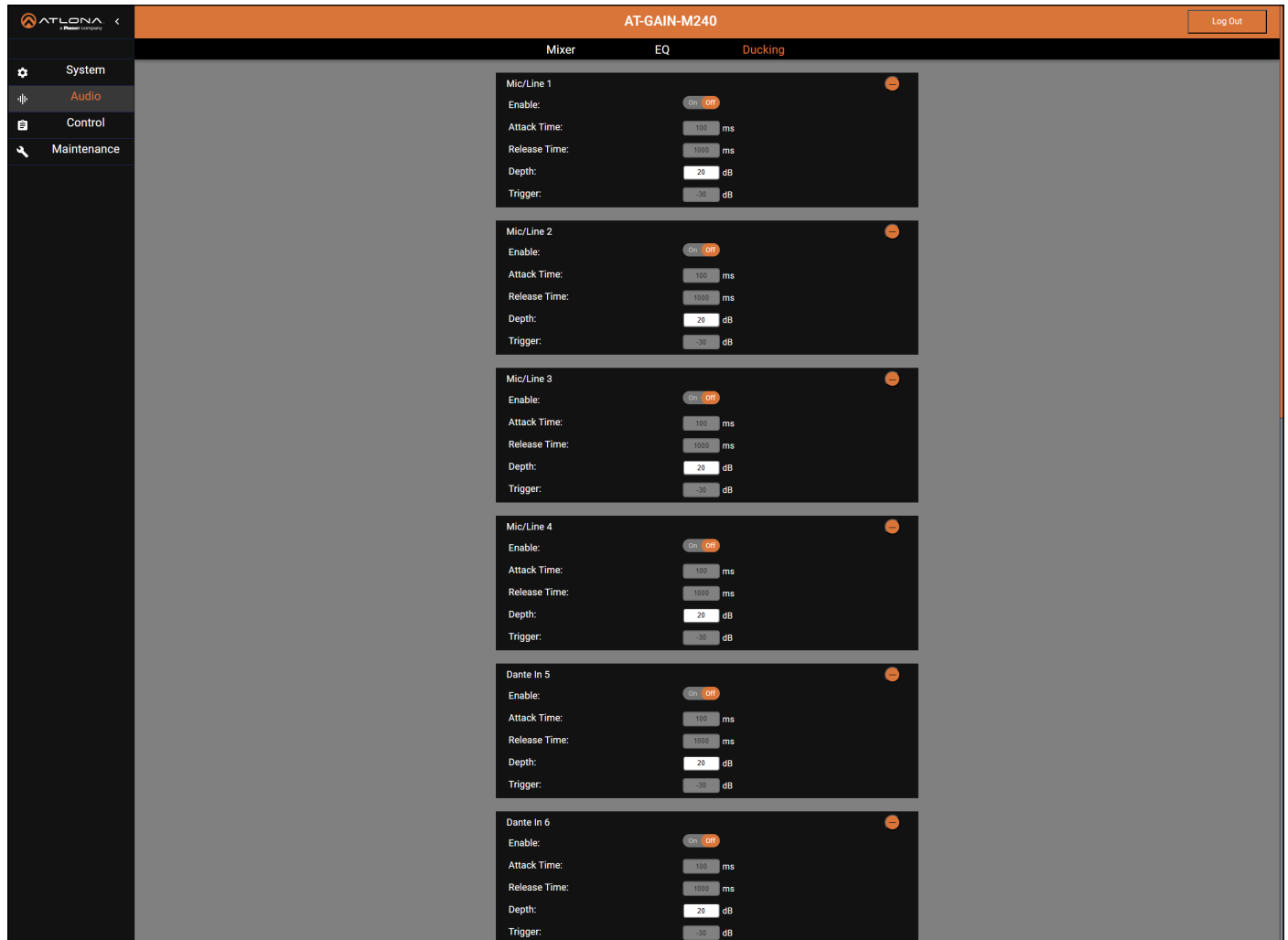

The screenshot displays the AT-GAIN-M240 configuration interface, specifically the 'Ducking' tab. The interface is organized into a sidebar on the left with navigation options: System, Audio (selected), Control, and Maintenance. The main content area shows six input channels, each with a set of adjustable parameters:

- Mic/Line 1**: Enable: On, Attack Time: 100 ms, Release Time: 1000 ms, Depth: 20 dB, Trigger: -30 dB
- Mic/Line 2**: Enable: On, Attack Time: 100 ms, Release Time: 1000 ms, Depth: 20 dB, Trigger: -30 dB
- Mic/Line 3**: Enable: On, Attack Time: 100 ms, Release Time: 1000 ms, Depth: 20 dB, Trigger: -30 dB
- Mic/Line 4**: Enable: On, Attack Time: 100 ms, Release Time: 1000 ms, Depth: 20 dB, Trigger: -30 dB
- Dante In 5**: Enable: On, Attack Time: 100 ms, Release Time: 1000 ms, Depth: 20 dB, Trigger: -30 dB
- Dante In 6**: Enable: On, Attack Time: 100 ms, Release Time: 1000 ms, Depth: 20 dB, Trigger: -30 dB

Enable

Click this toggle to enable or disable ducking for the selected input. When set to **On**, the input can trigger ducking based on its signal level and the defined parameters. When set to **Off**, ducking is disabled for that input.

Attack Time

This field controls how quickly the background audio is reduced after the trigger signal (e.g., voice) is detected. This value is in milliseconds (ms).

Release Time

This field determines how quickly the background audio returns to its original level after the trigger signal (e.g., voice) stops. This field is measured in milliseconds (ms).

Depth

Sets the amount of volume reduction, measured in decibels (dB), applied to the background audio when ducking is active. This is the only ducking parameter that can be adjusted while the input is disabled, allowing the desired attenuation level to be set in advance before enabling ducking.

Trigger

Defines the audio level, measured in decibels (dB), at which ducking is activated.

Control > Control

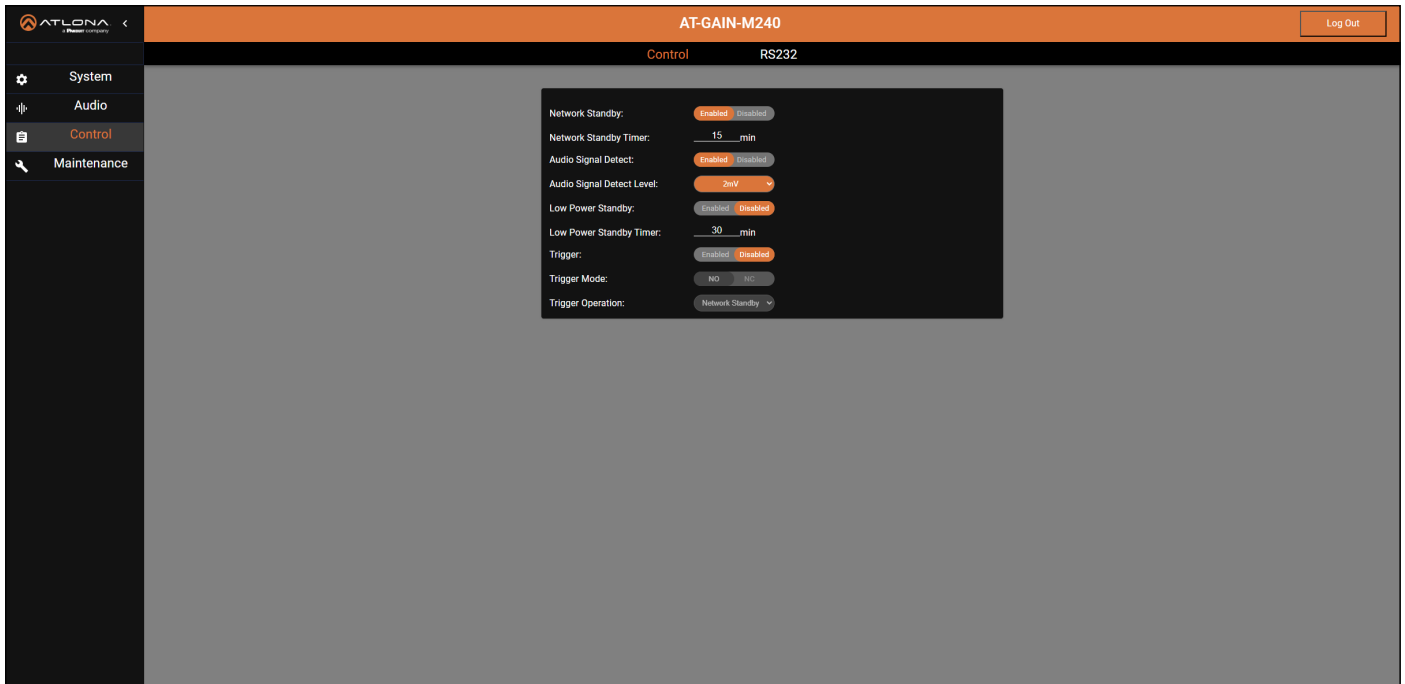

Network Standby

Use this toggle to enable or disable Network Standby. When enabled, the device enters a power-saving mode while remaining accessible on the network, allowing it to be awakened as needed using IP API commands.

Network Standby Timer

Specifies the number of minutes before the amplifier is placed in standby mode.

Audio Signal Detect

Defines the minimum voltage threshold of the incoming audio signal needed to activate detection. The available range is 2mV to 7mV. A lower setting, such as 2mV, increases sensitivity, allowing the device to respond to very low-level audio signals.

Low Power Standby

Set this toggle to **Enabled** to place the device into a deeper power-saving mode when not in use. This mode reduces power consumption compared to Network Standby and is ErP compliant. When set to **Enabled**, the device can be brought out of standby only via RS-232 or a trigger input. After waking, it may take a short time before the device becomes accessible over IP.

Low Power Standby Timer

Specifies how long the device must remain idle before switching to low power standby.

Trigger

Click this toggle switch to the **Enabled** position to control the power state through a physical trigger input.

Trigger Mode

Click this toggle switch to select between NO (Normally Open) or NC (Normally Closed) contact-closure behavior.

Trigger Operation

Click this drop-down list to select the desired operation: Network Standby, Low Power Standby, Mute.

Configuration and Management Interfaces

Control > RS232

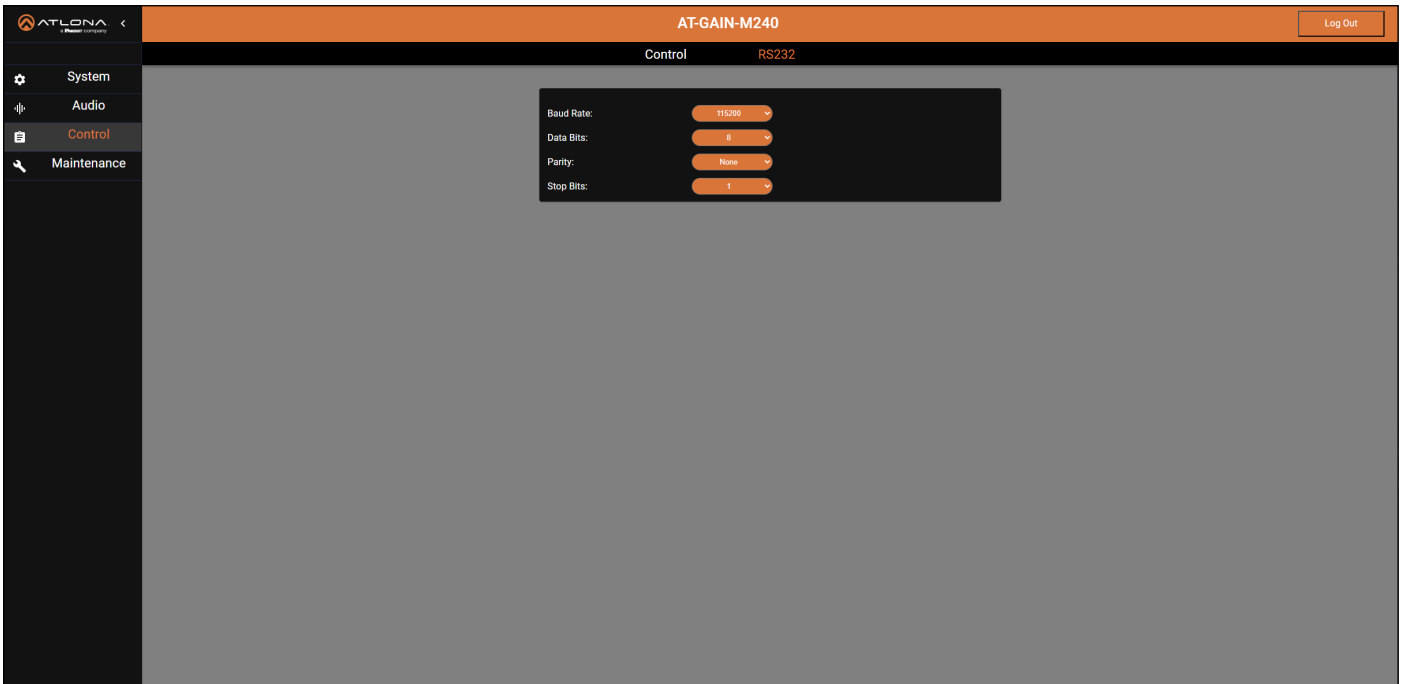

Baud Rate

Click this drop-down list to select the data transmission rate in bit-per-second (bps). Available options are 9600, 19200, 38400, 57600, or 115200. The default setting is 115200.

Data Bits

Click this drop-down list to select the number of data bits in each packet. Typically, packets are sent in bytes (8 bits). However, some older systems may use 7-bit data. Available options are 7 or 8. The default setting is 8.

Parity

Click this drop-down list to select the parity bit value. The parity bit helps detect single-bit errors in data transmission. The parity bit cannot correct errors. However, if an error does occur, the receiver can then request that the data be retransmitted.

Setting	Description
NONE	No parity (error checking) is applied. This is the default setting.
ODD	The parity bit is set so that the total number of 1 bits in the data, including the parity bit, is <i>odd</i> . For example, 10110011 contains five 1 bits, which is an odd value. Applying ODD parity, the parity bit is set to 0 and the data becomes 101100110, maintaining an odd number of 1 bits in the data.
EVEN	The parity bit is set so that the total number of 1 bits in the data, including the parity bit, is <i>even</i> . For example, 10110011 contains five 1 bits, which is an odd value. Applying EVEN parity, the parity bit is set to 1 and the data becomes 101100111, maintaining an even value of 1 bits in the data.

Stop Bits

Click this drop-down list to select the number of stop bits. Stop bits are used to signal the end of a data frame. A value of 1 is standard. Available options are 1 or 2.

Configuration and Management Interfaces

Maintenance > System

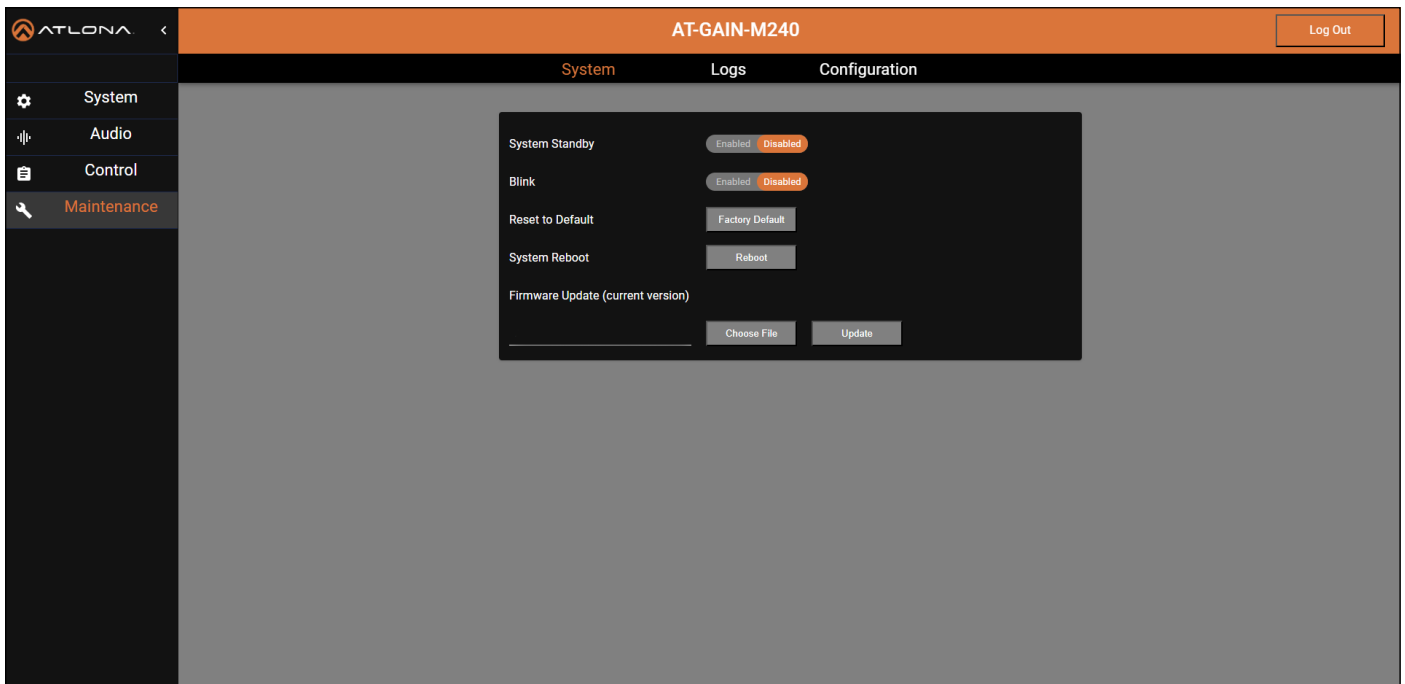

System Standby

Click this toggle to enable or disable System Standby. When set to **Enabled**, the AT-GAIN-M120 / M240 enters standby mode; the default setting is **Disabled**. This control manually places the device in and out of standby using the standby mode configured on the **Control** page. The two standby modes are interlocked—enabling one mode automatically disables the other (as shown in the web interface).

Blink

Click this toggle switch to **Enabled** or **Disabled**. When set to **Enabled**, the LED indicators on the front panel will blink. This is useful for identifying a unit, in a rack mount environment. This feature is set to **Disabled** by default.

Reset to Default

Click the **Factory Default** button to reset the AT-GAIN-M120 / M240 to factory-default settings.

System Reboot

Click the **Reboot** button to reset the AT-GAIN-M120 / M240 to factory-default settings.

Firmware Update

Click the **Choose File** button to begin the firmware update procedure. Refer to [Updating the Firmware \(page 55\)](#) for more information.

Configuration and Management Interfaces

Maintenance > Logs

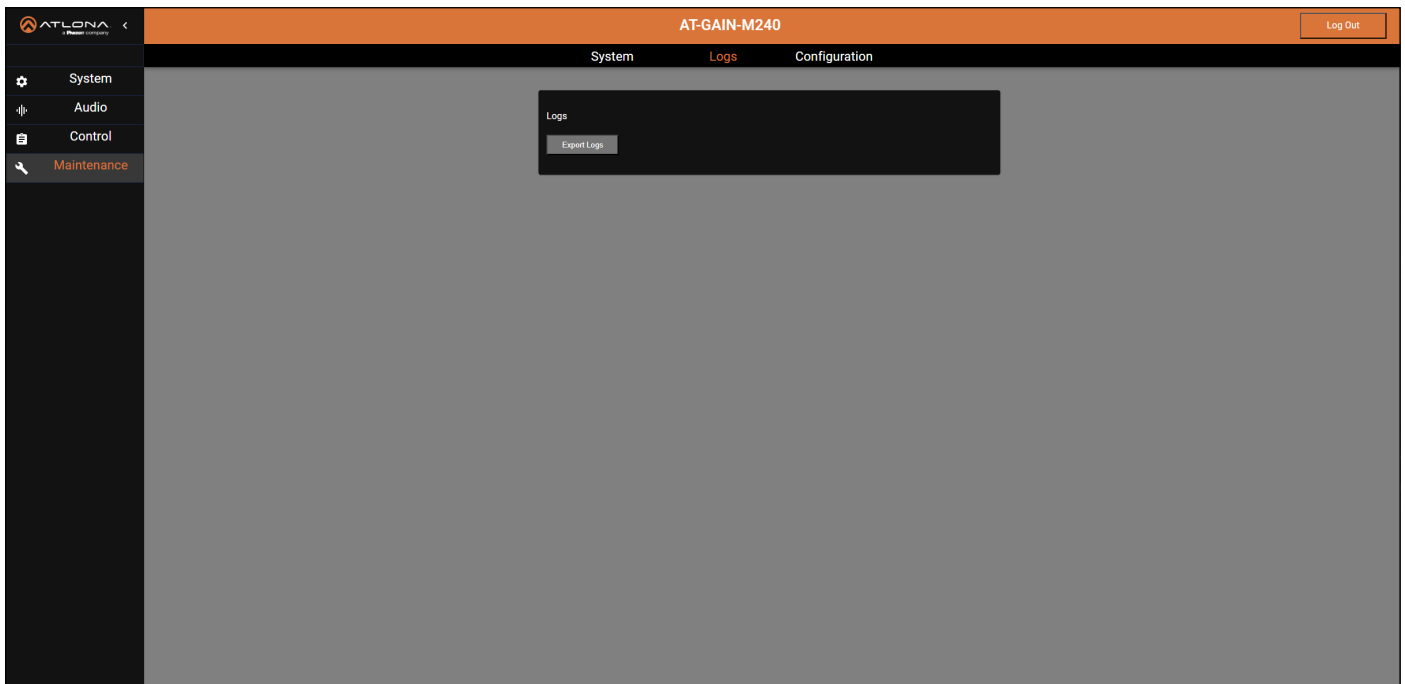

Logs

Click the **Export Logs** button to export the system log. A log of the ARM, MCU, and web sub-system can be exported for debugging and technical support purposes.

Configuration and Management Interfaces

Maintenance > Configuration

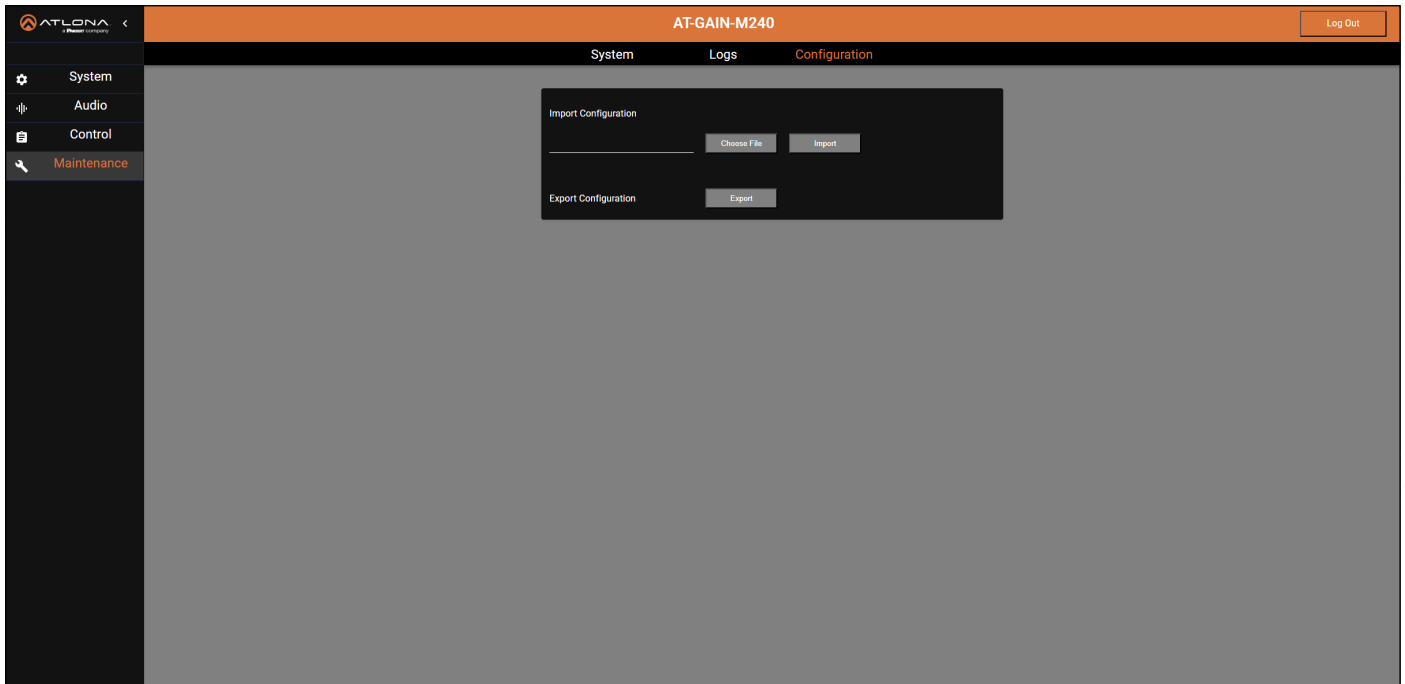

The AT-GAIN-M120 / M240 system configuration can be exported, if desired.

Choose File

Click this button to select the desired configuration file to be uploaded to the AT-GAIN-M120 / M240.

Update

Click this button to upload the configuration file.

Export

Click this button to export the system configuration file. System configuration files are exported in JSON format.

Appendix

Updating the Firmware

Updating the firmware can be performed using the built-in web server or over USB.

Updating using the built-in Web Server

Requirements:

- AT-GAIN-M120 / M240
 - Firmware file
 - Computer on the same network as the AT-GAIN-M120 / M240
1. Download the firmware file from atlon.com and extract the contents of the .zip file to a folder on the computer desktop. The firmware file will be in .dat format.
 2. Power on the unit and connect an Ethernet cable from the computer, containing the firmware, to the same network where the AT-GAIN-M120 / M240 is connected.
 3. Login to the web server.
 4. Click **System > Maintenance** in the menu bar.

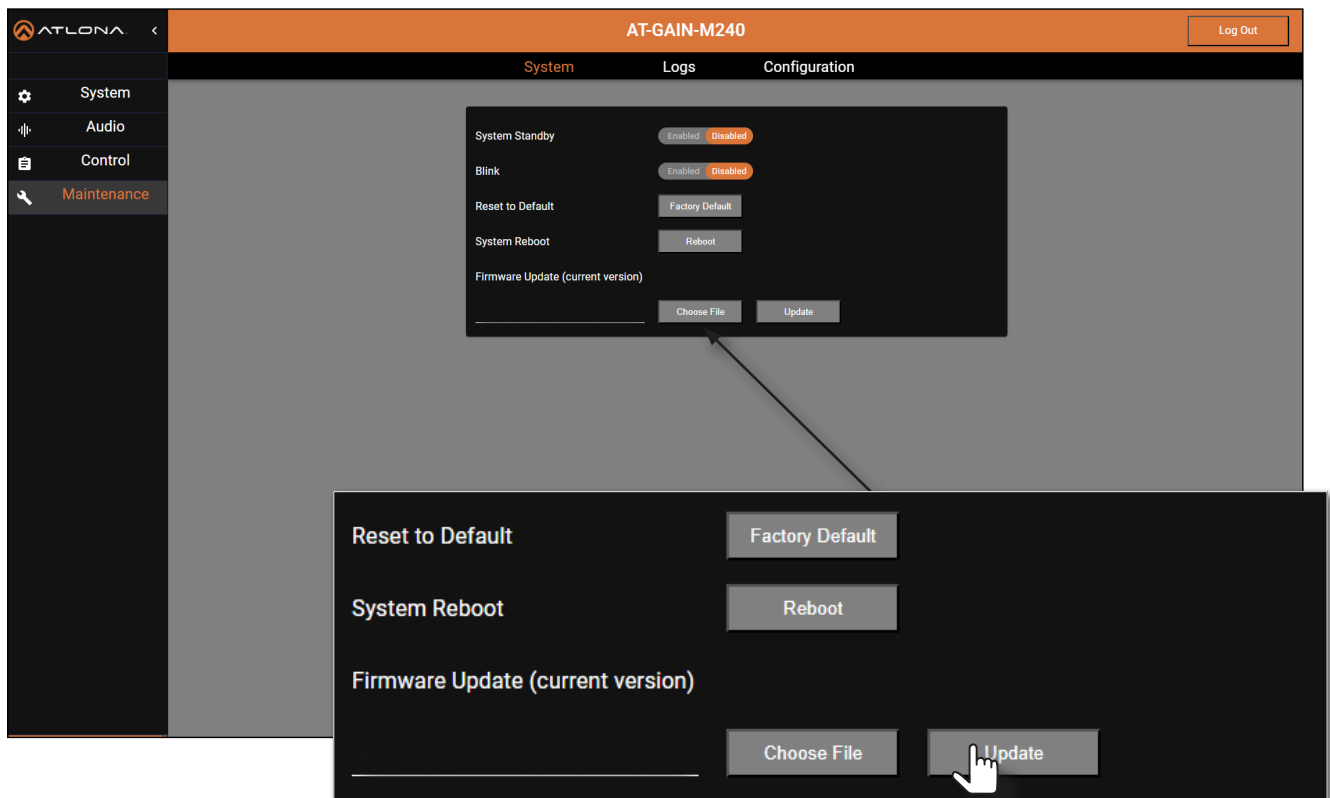

5. Click the **Choose File** button.
6. Browse to the location of the firmware file, select it, and click the **Open** button.
7. Click the **Update** button.



IMPORTANT: Do not power off the AT-GAIN-M120 / M240 during the update procedure.

8. After the update process has completed, the AT-GAIN-M120 / M240 will automatically reboot.
9. After rebooting, the **Login** screen will be displayed.

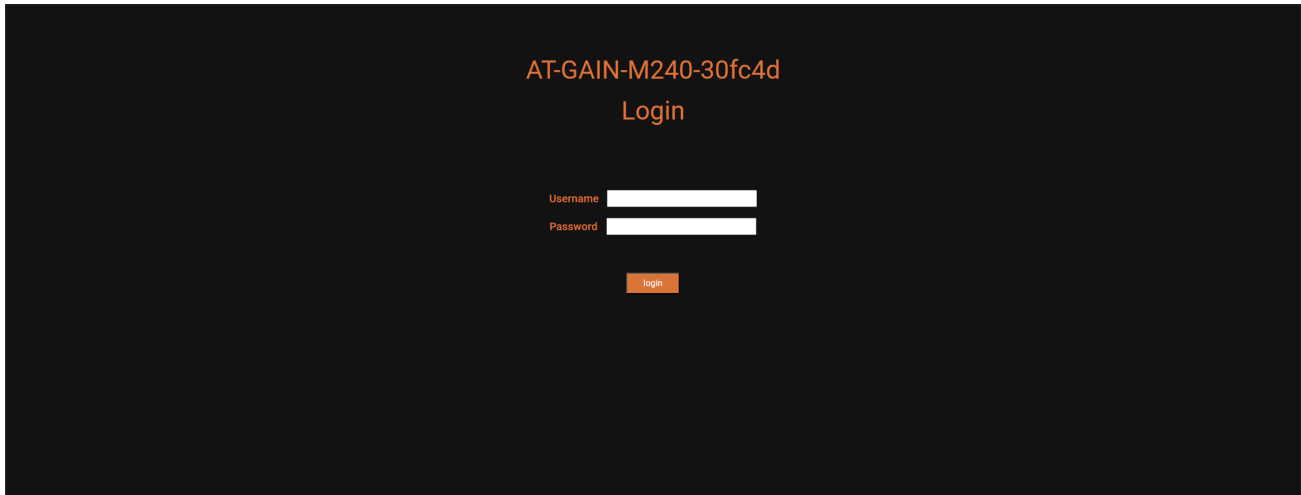

Updating over USB

Requirements:

- Use a USB-C flash drive with a capacity of 32 GB or less.
 - Format the USB-C flash drive as FAT32.
 - Unzip the firmware package and copy the firmware file to the root of the USB drive.
1. Power on the unit.
 2. Insert the USB-C flash drive (containing the firmware file) into the device.
 3. The device will automatically begin the update. Front-panel LEDs will flash while the firmware is being transferred and installed.
 4. If the firmware file is valid, the device will complete the update and reboot automatically. If the file is invalid, the update will stop and an error message will be shown in the web interface.
 5. After reboot, the device performs a file system check. **Do not** power off the device during this process. Powering off before the check completes may cause the device to roll back to the previous firmware version.

Web Interface Status Messages

During the update, the web interface displays the following messages:

1. When the update begins:
USB update is started. Please do not power off the device.
2. If the update fails, one of the following messages is shown:
 - *USB update failed: USB format is not correct, should be FAT32.*
 - *USB update failed: USB inserted does not contain a firmware file.*
 - *USB update failed: not a valid firmware.*
 - *USB update failed: read firmware failed.*
3. When the firmware update completes:
USB update finished. Please refresh the web page.

During the file system check after reboot:
Checking filesystem: progress%. Please do not power off the device.

When the file system check is complete:
Filesystem check finished.

Rack Mount Installation

The AT-GAIN-120 can be mounted in different ways, based on the number of units that are being installed. When installed into a standard 19" rack, the AT-RACK-1RU will need to be purchased from atlonacom.com.

The AT-RACK-1RU can be used to either mount a single AT-GAIN-M120 / M240 unit or it can be used to mount multiple half-rack Atlona products.



IMPORTANT: The AT-RACK-1RU rack shelf is a required accessory to ensure a proper, secure rack installation. Additionally, 2U of space will be required to install the AT-GAIN-M120 / M240 in a rack. Before mounting the AT-GAIN-M120 / M240 to the AT-RACK-1RU, remove the rubber feet from the bottom of the unit.

1. Place the AT-GAIN-M120 / M240 on a flat surface, upside down.
2. Turn the AT-RACK-1RU upside down, placing it on top of the AT-GAIN-120, as shown, and align the holes of the AT-RACK-1RU, marked in blue, with the mounting holes on the AT-GAIN-120.
3. Use the included 7 mm screws to secure the AT-RACK-1RU to the AT-GAIN-120.



IMPORTANT: To prevent possible damage to the device, rack, and/or screws, do not overtighten or use high-torque devices when securing the devices to the rack.

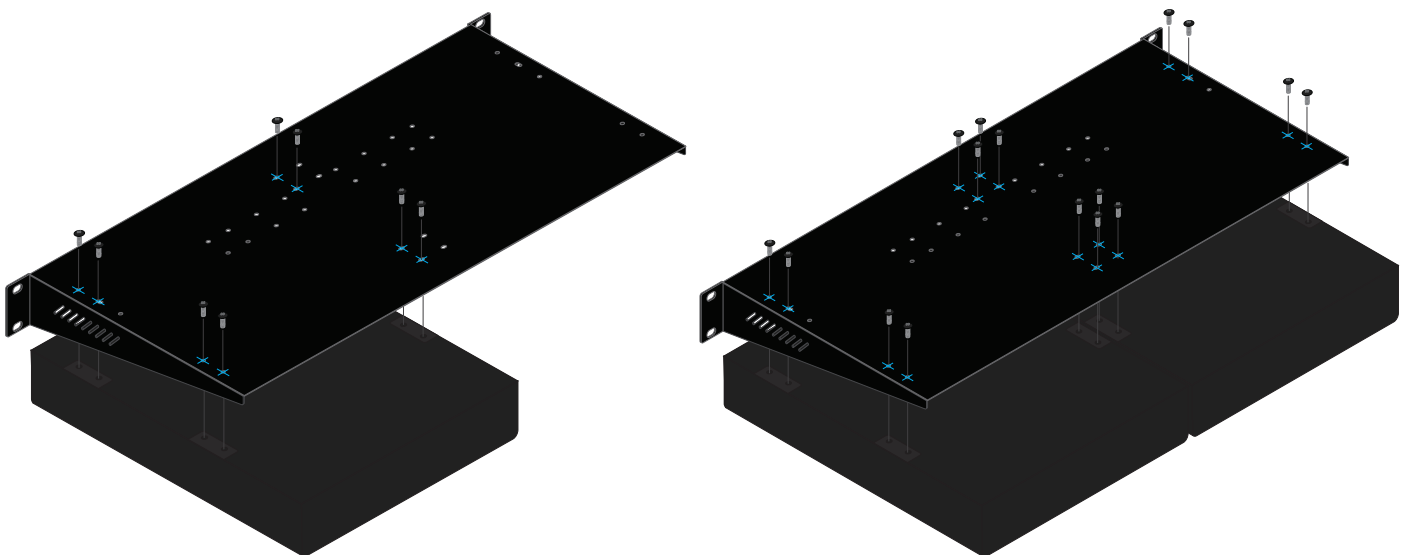

Specifications

AT-GAIN-M120

Inputs	
Mic / Line	4 analog inputs, configurable individually as microphone or line level Microphone Input Level: -50 dBV (typical) Consumer Line Level: -10 dBV Professional Line Level: +4 dBV
Dante	2 channels using AT-GAIN-NET (optional module)
Impedance	> 20 kΩ
Signal Detection Threshold	≤ 1 Vrms (-60 dBV) at 1 kHz
Phantom Power	+48 VDC, 10 mA (available when input is set to mic level)

Outputs	
Type	Class D
Modes	Stereo (4/8 Ω) or Mono 70V/100V
Impedance	< 10 kΩ
Line-Level	Stereo, unpowered

Amplifier Performance	
Power	2 × 60 W @ 4/8 Ω; 1 × 120 W @ 70V or 100V (mono)
Frequency Response	Low Impedance: 20 Hz – 20 kHz (±1 dB) High Impedance: 200 Hz – 12 kHz (±1 dB), 80 Hz – 20 kHz (±3 dB)
THD+N	0.1% @ 1 kHz, 3 dB below full output, 8 Ω 0.3% from 100 Hz to 16 kHz, 3 dB below full output, 4/8 Ω
SNR	> 85 dB
CMRR	> 75 dB @ 60 Hz, 1 kHz, 10 kHz

Signal Processing	
High-Pass Filter	Butterworth, selectable slopes: 6/12/18/24/30 dB/oct
Low-Pass Filter	Butterworth, selectable slopes: 6/12/18/24/30 dB/oct
5-Band Parametric EQ	Center Frequency: 20 Hz – 20 kHz Q Factor: 1 – 15 Gain: -36 dB to +12 dB
Delay	0 – 30 ms (adjustable in 0.1 ms steps)

Ethernet	
Port	1 x RJ45
Standards and Protocols	HTTP, HTTPS, mDNS
Speeds	10/100/1000 Mbps
Addressing	DHCP, Static

RS-232	
Port	1 x 8-pin captive screw, TX, RX, GND
Use	Device control and configuration
Baud Rates	9600, 19200, 38400, 57600, 115200
Data Flow	Bidirectional

Buttons and Indicators	
Buttons: IP MODE, RESET MODE	2 x momentary, tact-type, recessed 1 x 4-position slide switch
Indicators: PWR, MUTE MIC / LINE IN (1 - 4) NET IN (5 - 6) IP MODE, RESET VOL LEVEL	2 x LED, green 4 x LED, green 2 x LED, green 2 x LED, green 1 x 10-segment LED level meter (green, yellow, red)

Connectors	
MIC/LINE IN	2 x 6-pin captive screw
4/8 Ω OUT	1 x 4-pin, 5.08 mm lock-down screw connector
70V / 100V OUT	1 x 2-pin, 5.08 mm lock-down screw connector
LINE OUT	1 x 6-pin captive screw
TRIGGER/CTRL/RS-232	1 x 8-pin captive screw
LAN	1 x RJ45
FW	1 x USB type C, female
PWR	1 x IEC

Environmental	Fahrenheit	Celsius
Operating Temperature	+32 to +122	0 to +50
Storage Temperature	-4 to +140	-20 to +60
Operating Humidity (RH)	20% to 90%, non-condensing	

Power	
Low Power Mode	0.5 W
Network Standby Mode	2 W
Auto-Standby Timer	Configurable from 1 to 1440 minutes
BTU/h	12.3 (idle) 67.9 (maximum power)
Supply	100 - 240 V AC, 50/60 Hz

Dimensions (H x W x D)	Inches	Millimeters
Unit	1.75 x 8.875 x 13	44 x 225 x 330

Weight	Pounds	Kilograms
Device	6.94	3.15

Certification	
Device	CE, RoHS, FCC

Compliance	
NDAA-889	Yes
TAA	No

Warranty	
3 years	View the full warranty information here: https://atlon.com/warranty

AT-GAIN-M240

Inputs	
Mic / Line	4 analog inputs, configurable individually as microphone or line level Microphone Input Level: -50 dBV (typical) Consumer Line Level: -10 dBV Professional Line Level: +4 dBV
Dante	2 channels using AT-GAIN-NET (optional module)
Impedance	> 20 k Ω
Signal Detection Threshold	≤ 1 Vrms (-60 dBV) at 1 kHz
Phantom Power	+48 VDC, 10 mA (available when input is set to mic level)

Outputs	
Type	Class D
Modes	Stereo (4/8 Ω) or Mono 70V/100V
Impedance	< 10 k Ω
Line-Level	Stereo, unpowered

Amplifier Performance	
Power	2 x 120 W @ 4/8 Ω ; 1 x 240 W @ 70V or 100V (mono)
Frequency Response	Low Impedance: 20 Hz – 20 kHz (± 1 dB) High Impedance: 200 Hz – 12 kHz (± 1 dB), 80 Hz – 20 kHz (± 3 dB)
THD+N	0.1% @ 1 kHz, 3 dB below full output, 8 Ω 0.3% from 100 Hz to 16 kHz, 3 dB below full output, 4/8 Ω
SNR	> 85 dB
CMRR	> 75 dB @ 60 Hz, 1 kHz, 10 kHz

Signal Processing	
High-Pass Filter	Butterworth, selectable slopes: 6/12/18/24/30 dB/oct
Low-Pass Filter	Butterworth, selectable slopes: 6/12/18/24/30 dB/oct
5-Band Parametric EQ	Center Frequency: 20 Hz – 20 kHz Q Factor: 1 – 15 Gain: -36 dB to +12 dB
Delay	0 – 30 ms (adjustable in 0.1 ms steps)

Ethernet	
Port	1 x RJ45
Standards and Protocols	HTTP, HTTPS, mDNS
Speeds	10/100/1000 Mbps
Addressing	DHCP, Static

RS-232	
Port	1 x 8-pin captive screw, TX, RX, GND
Use	Device control and configuration
Baud Rates	9600, 19200, 38400, 57600, 115200
Data Flow	Bidirectional

Buttons and Indicators	
Buttons: IP MODE, RESET MODE	2 x momentary, tact-type, recessed 1 x 4-position slide switch
Indicators: PWR, MUTE MIC / LINE IN (1 - 4) NET IN (5 - 6) IP MODE, RESET VOL LEVEL	2 x LED, green 4 x LED, green 2 x LED, green 2 x LED, green 1 x 10-segment LED level meter (green, yellow, red)

Connectors	
MIC/LINE IN	2 x 6-pin captive screw
4/8 Ω OUT	1 x 4-pin, 5.08 mm lock-down screw connector
70V / 100V OUT	1 x 2-pin, 5.08 mm lock-down screw connector
LINE OUT	1 x 6-pin captive screw
TRIGGER/CTRL/RS-232	1 x 8-pin captive screw
LAN	1 x RJ45
FW	1 x USB type C, female
PWR	1 x IEC

Environmental	Fahrenheit	Celsius
Operating Temperature	+32 to +122	0 to +50
Storage Temperature	-4 to +140	-20 to +60
Operating Humidity (RH)	20% to 90%, non-condensing	

Power	
Low Power Mode	0.5 W
Network Standby Mode	2 W
Auto-Standby Timer	Configurable from 1 to 1440 minutes
BTU/h	12.3 (idle) 67.9 (maximum power)
Supply	100 - 240 V AC, 50/60 Hz

Dimensions (H x W x D)	Inches	Millimeters
Unit	1.75 x 8.875 x 13	44 x 225 x 330

Weight	Pounds	Kilograms
Device	6.94	3.15

Certification	
Device	CE, RoHS, FCC

Compliance	
NDAA-889	Yes
TAA	No

Warranty	
3 years	View the full warranty information here: https://atlon.com/warranty

Accessories

SKU	Description
AT-GAIN-VOL	Volume Control Wallplate
AT-GAIN-NET	AES67 / Dante Network Audio Interface

