

USB to IP Adapter for Host Device

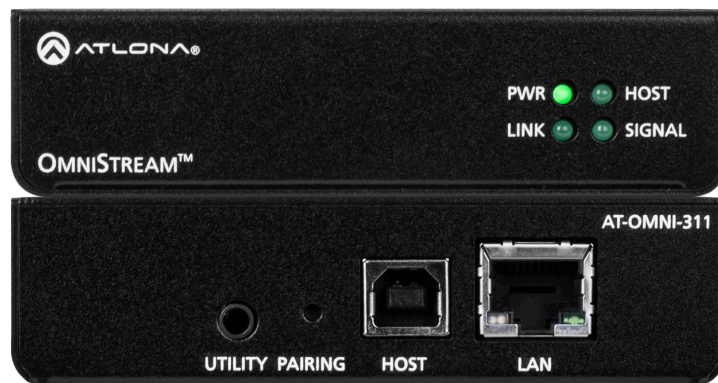

Version Information

Version	Release Date	Notes
4	Jan 2024	Updated warranty information

Sales, Marketing, and Customer Support

Main Office

Atlona Incorporated
70 Daggett Drive
San Jose, CA 95134
United States

Office: +1.408.962.0515

Sales and Customer Service Hours
Monday - Friday: 6:00 a.m. - 4:30 p.m. (PST)

<https://atlona.com/>

International Headquarters

Atlona International AG
Tödistrasse 18
8002 Zürich
Switzerland

Office: +41.43.508.4321

Sales and Customer Service Hours
Monday - Friday: 09:00 - 17:00 (UTC +1)

Operating Notes



IMPORTANT: Visit <http://www.atlona.com/product/AT-OMNI-311> for the latest firmware updates and User Manual.

Warranty



To view the product warranty, use the following link or QR code:

<https://atlona.com/warranty/>.

Important Safety Information



CAUTION: TO REDUCE THE RISK OF ELECTRIC SHOCK DO NOT OPEN ENCLOSURE OR EXPOSE TO RAIN OR MOISTURE. NO USER-SERVICEABLE PARTS INSIDE REFER SERVICING TO QUALIFIED SERVICE PERSONNEL.



The exclamation point within an equilateral triangle is intended to alert the user to the presence of important operating and maintenance instructions in the literature accompanying the product.



The information bubble is intended to alert the user to helpful or optional operational instructions in the literature accompanying the product.

1. Read these instructions.
2. Keep these instructions.
3. Heed all warnings.
4. Follow all instructions.
5. Do not use this product near water.
6. Clean only with a dry cloth.
7. Do not block any ventilation openings. Install in accordance with the manufacturer's instructions.
8. Do not install or place this product near any heat sources such as radiators, heat registers, stoves, or other apparatus (including amplifiers) that produce heat.
9. Do not defeat the safety purpose of a polarized or grounding-type plug. A polarized plug has two blades with one wider than the other. A grounding type plug has two blades and a third grounding prong. The wide blade or the third prong are provided for your safety. If the provided plug does not fit into your outlet, consult an electrician for replacement of the obsolete outlet.
10. Protect the power cord from being walked on or pinched particularly at plugs, convenience receptacles, and the point where they exit from the product.
11. Only use attachments/accessories specified by Atlona.
12. To reduce the risk of electric shock and/or damage to this product, never handle or touch this unit or power cord if your hands are wet or damp. Do not expose this product to rain or moisture.
13. Unplug this product during lightning storms or when unused for long periods of time.
14. Refer all servicing to qualified service personnel. Servicing is required when the product has been damaged in any way, such as power-supply cord or plug is damaged, liquid has been spilled or objects have fallen into the product, the product has been exposed to rain or moisture, does not operate normally, or has been dropped.



FCC Compliance

FCC Compliance and Advisory Statement: This hardware device complies with Part 15 of the FCC rules. Operation is subject to the following two conditions: 1) this device may not cause harmful interference, and 2) this device must accept any interference received including interference that may cause undesired operation. This equipment has been tested and found to comply with the limits for a Class A digital device, pursuant to Part 15 of the FCC Rules. These limits are designed to provide reasonable protection against harmful interference in a commercial installation. This equipment generates, uses, and can radiate radio frequency energy and, if not installed or used in accordance with the instructions, may cause harmful interference to radio communications. However there is no guarantee that interference will not occur in a particular installation. If this equipment does cause harmful interference to radio or television reception, which can be determined by turning the equipment off and on, the user is encouraged to try to correct the interference by one or more of the following measures: 1) reorient or relocate the receiving antenna; 2) increase the separation between the equipment and the receiver; 3) connect the equipment to an outlet on a circuit different from that to which the receiver is connected; 4) consult the dealer or an experienced radio/TV technician for help. Any changes or modifications not expressly approved by the party responsible for compliance could void the user's authority to operate the equipment. Where shielded interface cables have been provided with the product or specified additional components or accessories elsewhere defined to be used with the installation of the product, they must be used in order to ensure compliance with FCC regulations.

Copyright, Trademark, and Registration

2024 Atlona Inc. All rights reserved. "Atlona" and the Atlona logo are registered trademarks of Atlona Inc. Pricing, specifications and availability subject to change without notice. Actual products, product images, and online product images may vary from images shown here.

All other trademark(s), copyright(s), and registered technologies mentioned in this document are the properties of their respective owner(s).

Table of Contents

Introduction	6
Features	6
Package Contents	6
Panel Description	7
Installation	8
Connection Instructions	8
Over a Network	8
Direct Connection	8
Connection Diagrams	9
Basic Operation	10
LED Indicators	10
Pairing	11
Manual Pairing	11
Unpairing an Extender	12
Using Velocity™	12
DHCP Reset	21
Appendix	22
Specifications	22

Introduction

The Atlona OmniStream™ USB 311 (**AT-OMNI-311**) works in tandem with the OmniStream USB 324 (AT-OMNI-324) for extending USB from peripheral devices to a PC over Gigabit Ethernet. The OmniStream USB 311 interfaces with a PC or other host device, while the OmniStream USB 324 features a four-port USB hub for peripherals. The OmniStream USB over IP system is compatible with USB 2.0 data rates of up to 480 Mbps. It can be used with high-bandwidth devices including cameras, speaker phones, microphones, and DSPs, plus standard USB HID class devices such as a keyboard, mouse, or touch display. Up to seven OmniStream USB 324 units can be simultaneously paired to an OmniStream USB 311. Additionally, USB routing over the network can be managed using Atlona Management System (AMS) 2.0.

OmniStream USB products can be used in a wide variety of system design scenarios for soft codec conferencing and remote keyboard / mouse control. They are ideal for integrating USB audio and video devices as part of a fully IP-based meeting room system, in conjunction with OmniStream AV over IP devices and the Velocity Control System.

Features

- Extend USB over Gigabit Ethernet using CAT5e/6 cable
- USB host connection for PC
- Compatible with USB 2.0 data rates up to 480 Mbps
- Ideal for meeting room applications to extend USB from touch displays, cameras, speakerphones, DSPs, and more
- Design flexible and scalable AV systems in combination with OmniStream AV encoders and decoders
- Pairs simultaneously with up to seven OmniStream 324 units over a network
- USB signal routing configured and managed by AMS 2.0 (Atlona Management System)
- Ready for integration with Atlona Velocity™ Control System to manage USB signal routing
- Front panel LED indicators for power, network and USB host connectivity, and USB signal presence over IP
- Low-profile, 1 inch (25 mm) high enclosure
- Powered directly by the USB host device
- Includes installation guide and surface mounting brackets
- Award-winning 10 year limited product warranty

Package Contents

1 x AT-OMNI-311
2 x Mounting brackets
1 x Installation Guide

Panel Description

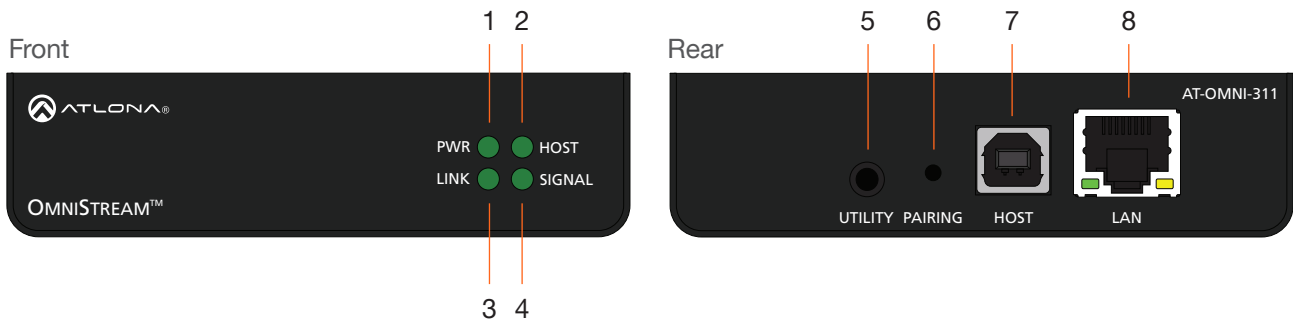

- 1 PWR**
 This LED indicator glows solid green when the unit is powered. This unit is powered by the host device using USB. No external power supply is required. Refer to [LED Indicators \(page 10\)](#) for more information.
- 2 HOST**
 This LED indicator glows green when a USB host device is connected to the unit. Refer to [LED Indicators \(page 10\)](#) for more information.
- 3 LINK**
 This LED indicator is solid green when a solid connection between this unit and the receiver has been established. Refer to [LED Indicators \(page 10\)](#) for more information.
- 4 SIGNAL**
 This LED indicator monitors data transmission between this unit and the receiver. The LED will blink intermittently whether or not a USB device is connected. Refer to [LED Indicators \(page 10\)](#) for more information.
- 5 UTILITY**
 This port is for factory programming.
- 6 PAIRING**
 Press this button to begin the pairing process.
- 7 HOST**
 Connect a USB type-B connector from this port to the host computer.
- 8 LAN**
 Connect an Ethernet cable from this port to the Local Area Network (LAN).

Installation

Connection Instructions



IMPORTANT: All network switch ports these devices are connected to should be configured as spanning tree edge ports or have the port configured with spanning tree PortFast enabled (depending on the switch manufacturer).



IMPORTANT: The AT-OMNI-324 supports a maximum of 3 additional USB hubs that may be connected downstream. Up to 7 AT-OMNI-324 units may be paired to an AT-OMNI-311, allowing up to a maximum of 31 USB devices.

1. Place the AT-OMNI-311 next to the USB host device and connect a USB cable from the **HOST** port to the host computer.

The AT-OMNI-311 can be connect to a AT-OMNI-324 (not included) in one of two ways:

Over a Network

- a. Connect an Ethernet cable, up to 330 feet (100 meters), from the **LAN** port on the AT-OMNI-311 to the network switch.
- b. Connect an Ethernet cable, up to 330 feet (100 meters), from the receiver (AT-OMNI-324; not included) to a switch on the same network.



NOTE: When connecting a transmitter and receiver, over a network, the cable distance between hops must not exceed 330 feet (100 meters) for copper connections (fiber extenders can be used to create longer runs). For example, connecting up to five network switches, using copper cabling, can be used to extend USB up to 1980 feet (600 meters).

Direct Connection

- a. Connect an Ethernet cable, up to 330 feet (100 meters), from the LAN port of the AT-OMNI-311 directly to the AT-OMNI-324 (not included).
2. The AT-OMNI-311 is powered by the host computer. No external power supply is required.
 3. Refer to [Pairing \(page 11\)](#) for instructions on pairing.

Connection Diagrams

Connection over a Local Area Network (LAN)

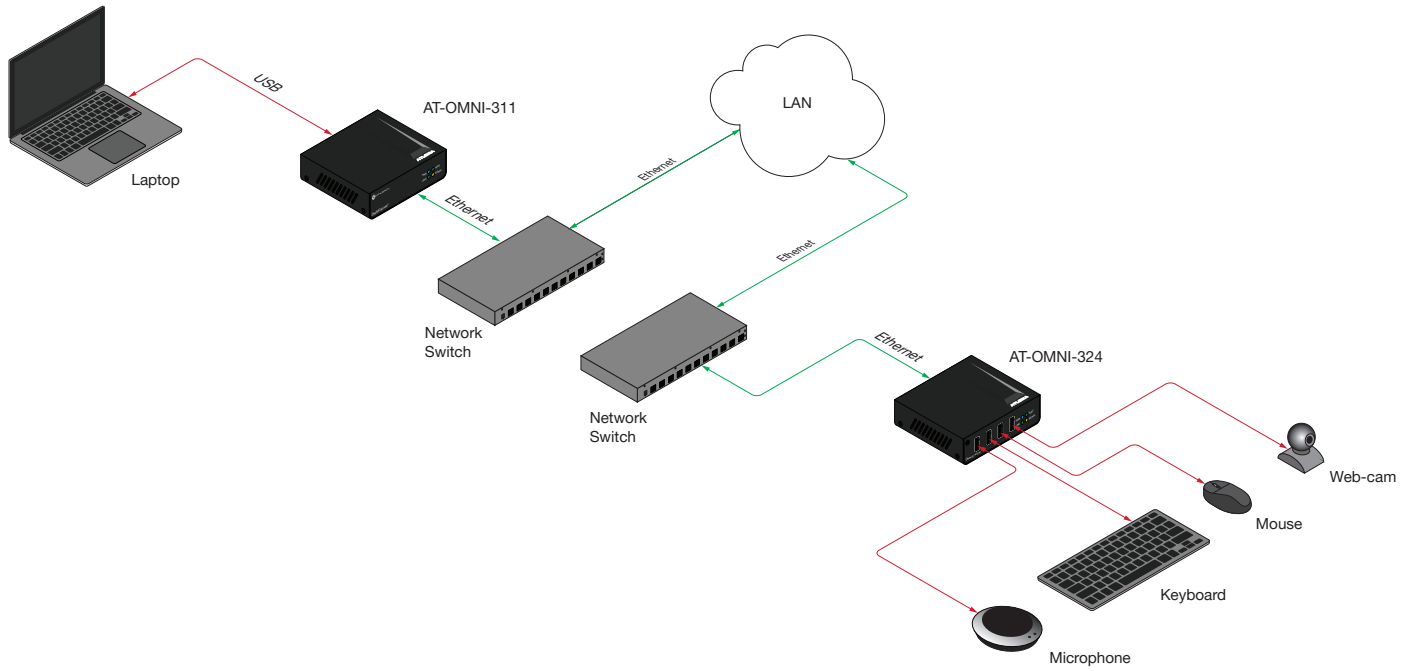



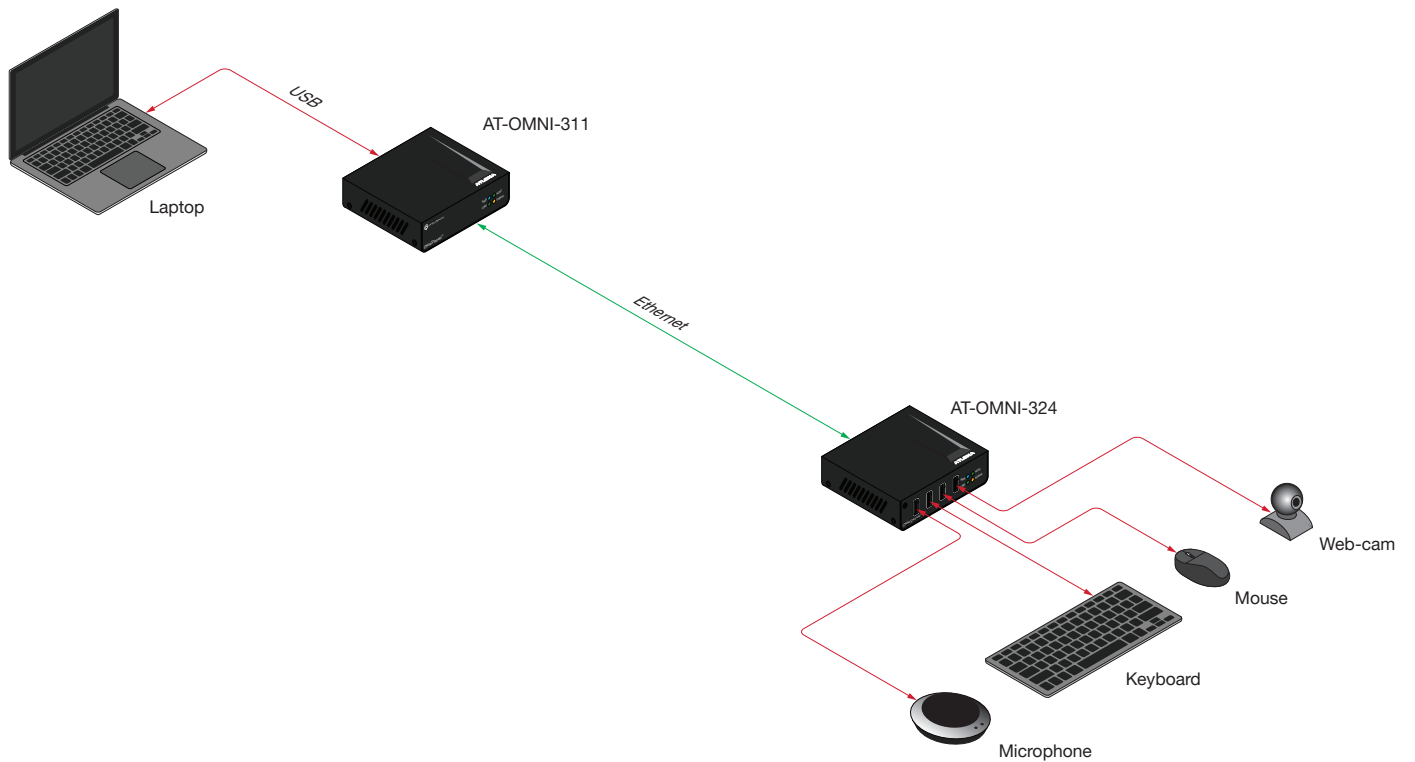







Direct Connection



Basic Operation

LED Indicators

The **PWR**, **LINK**, **HOST**, and **SIGNAL** LED indicators on the OmniStream 311 provide basic information on the current status of the unit.

LED		Description
PWR	Solid green 	Unit is powered.
	Off 	Unit is not powered. <ul style="list-style-type: none"> Verify that a USB Type-B cable is connected from the HOST port to the host computer.
LINK	Solid green 	The link integrity between the transmitter and the receiver is good.
	Blinking green (slow) 	The transmitter is attempting to establish a link to the receiver.
	Blinking green (fast) 	The transmitter is in Pairing Mode.
	Off 	There is no link between the transmitter and the receiver. <ul style="list-style-type: none"> Direct Mode: Verify that an Ethernet cable is connected between the LAN port on the transmitter and the receiver. Network Mode: Verify that an Ethernet cable is connected between the LAN port on the transmitter and the network switch. Check that the Ethernet cable is not physically damaged. Make sure that the Ethernet cable does not exceed 330 feet (100 meters).
HOST	Solid green 	The transmitter is properly enumerated on the host computer.
	Blinking green 	The transmitter is in a suspended state.
SIGNAL	Blinking green 	This LED indicator will blink intermittently when data is being transmitted between the transmitter and the receiver.
	Off 	The transmitter is in Suspend Mode.

Pairing

Manual Pairing

The OmniStream 311 and OmniStream 324 can also be paired manually. This applies when the OmniStream 311 and OmniStream 324 are connected, either through a network switch (on the same broadcast domain) or directly to one another using category cable. This instructions below cover manual pairing for both the OmniStream 311 and OmniStream 324.

1. Make sure both the OmniStream 311 and OmniStream 324 are connected, either directly or through a network switch, and that all USB connections have been made.

OmniStream 311

2. Press and hold the **PAIRING** button, for no more than 10 seconds, on the OmniStream 311 using the end of a paperclip or other pointed object.



IMPORTANT: Pressing the **PAIRING** button for *more* than 10 seconds will cancel the pairing mode.

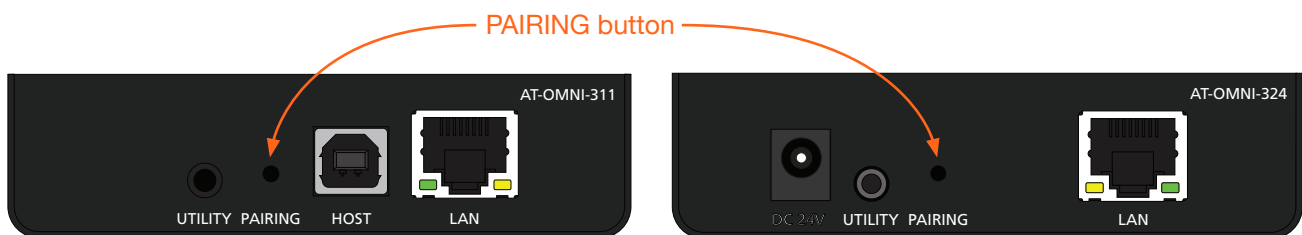

3. Release the **PAIRING** button. The **LINK** LED indicator will begin flashing. Pairing mode is now active on the OmniStream 311.



NOTE: To cancel pairing mode, press and hold the **PAIRING** button for more than 10 seconds.

OmniStream 324

4. Press and hold the **PAIRING** button on the OmniStream 324, for *no more* than 10 seconds, using the end of a paperclip or other pointed object.



IMPORTANT: Pressing the **PAIRING** button for *more* than 10 seconds will cancel the pairing mode. The **PAIRING** button on the OmniStream 324 must be pressed within 10 minutes of activating pairing mode on the OmniStream 311. If not, then the pairing process will automatically be cancelled.

5. Release the **PAIRING** button. The **LINK** LED indicator will begin flashing. Pairing mode is now active on the OmniStream 324.

The OmniStream 311 and OmniStream 324 will begin the linking process. During the linking process, the **LINK** LED indicator on both unit may flash more slowly. This is normal behavior.

Once both **LINK** LED indicators are solid green, the pairing process will be complete.

Unpairing an Extender

To unpair one extender from the other, press and hold the **PAIRING** button, on either of the connected units, for *more* than 10 seconds, then release.

Using Velocity™

The following section provides instructions on pairing AT-OMNI-311 units with AT-OMNI-324 units using the Atlona Velocity Control Software. Familiarity with the Velocity software is assumed. Refer to the *Atlona Velocity User Manual* for more information, if necessary.

1. Launch a web browser and enter the IP address of Velocity, in the address bar.
2. Enter the required login credentials.
3. Click the **Login** button.
4. The Velocity Dashboard will be displayed.
5. Click the ☰ icon, in the upper-left corner, to display the fly-out menu.

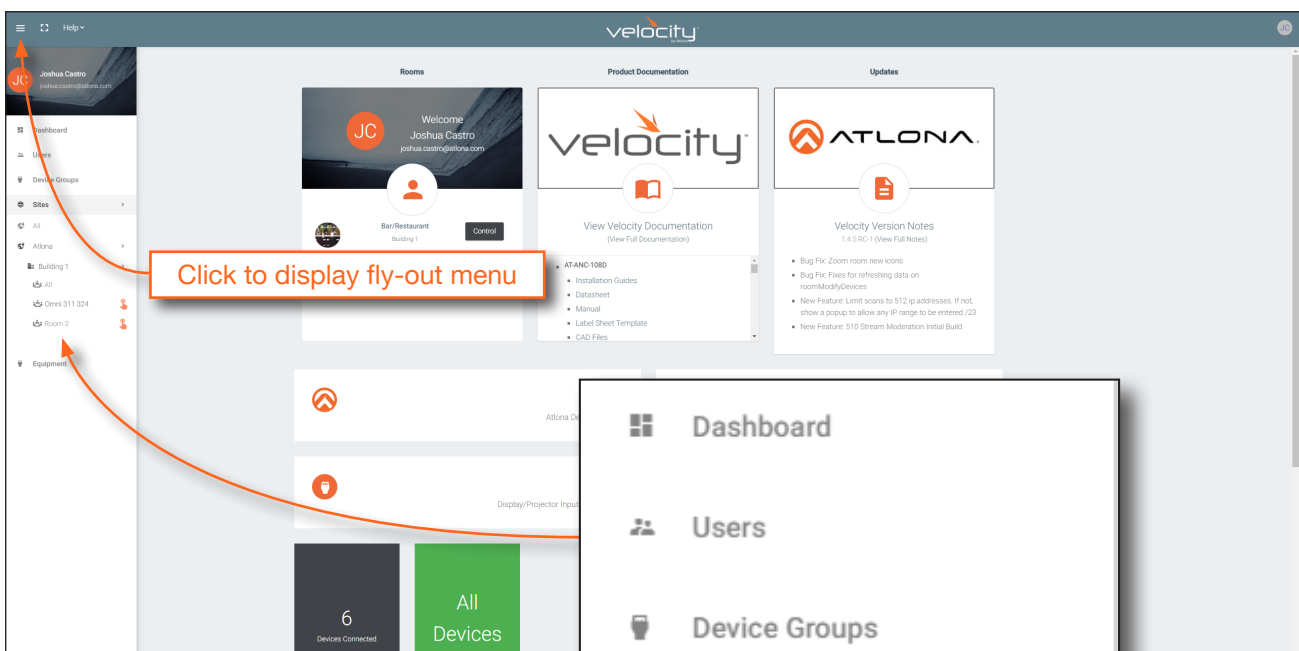

6. Click **Sites** in the menu bar to expand the list of buildings and rooms.
7. Click the desired room from the list.

In the example on the right, a set of units have been set up in a room called **Omni 311 324** within **Building 1**.

Refer to the *Velocity User Manual* for instructions on creating rooms and adding devices to rooms.

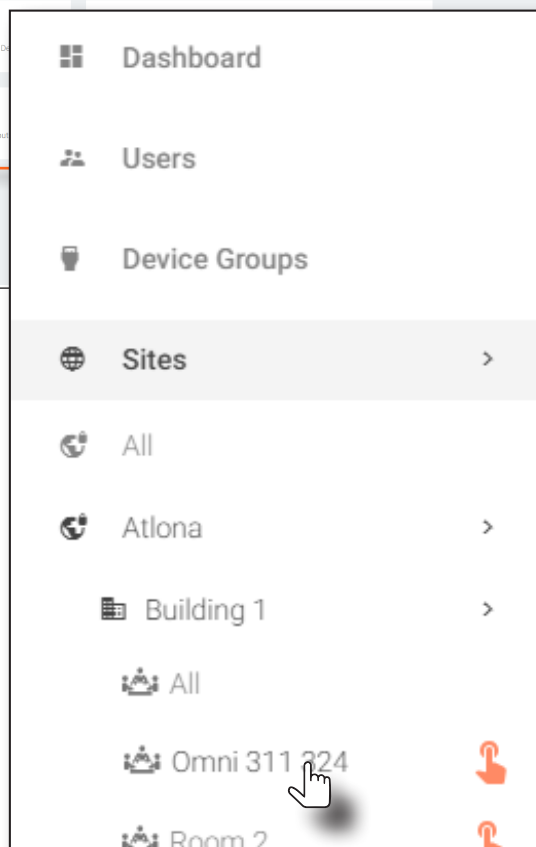

- The **Modify Room** screen will be displayed. Click the **Room Control Options** icon, in the upper-right corner of the **Technology** bar.

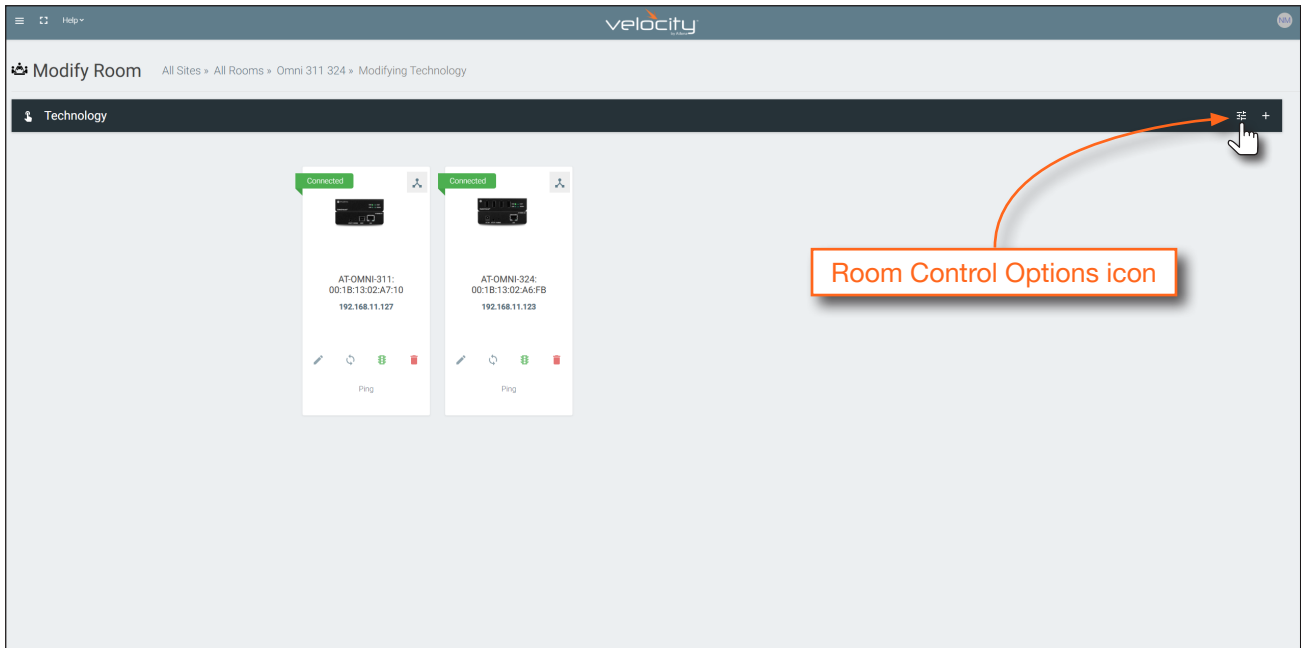

- The **Room Control Options** screen will be displayed. In order to allow units to be paired or unpaired, two macros will need be created: one for pairing and one for unpairing.

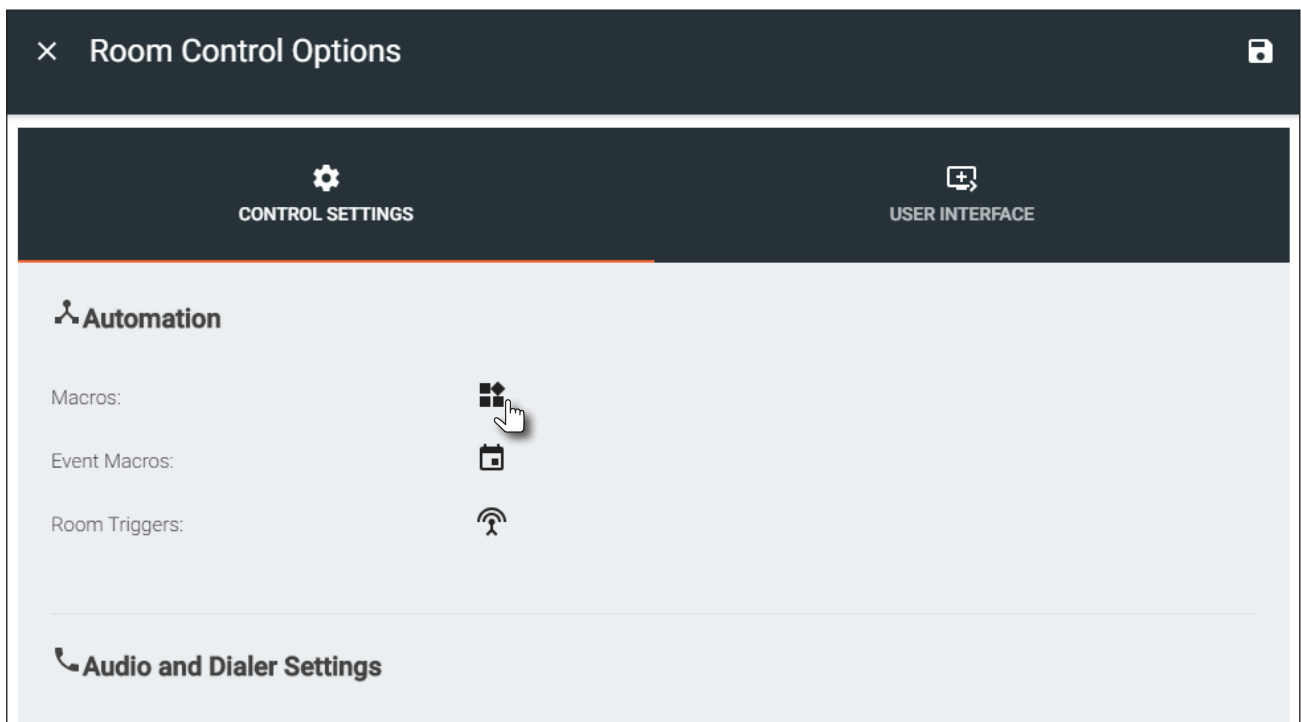

- Click the **Macros** icon to display the **Room Macros** screen.

Creating the Unpair Macro

9. The **Room Control Options** screen will be displayed. In order to allow units to be paired or unpaired, two

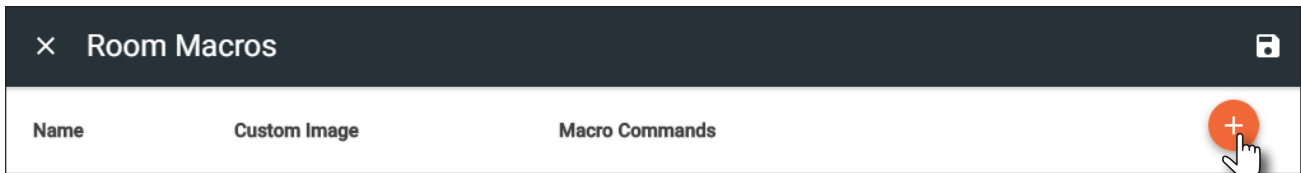

macros will need be created: one for pairing and one for unpairing.

10. Click the **Macros** icon to display the **Room Macros** screen.

1. In the **Room Macros** screen, click the **+** icon, in the upper-right corner of the screen.



2. Enter the name of the macro in both the **Name** and **Macro Commands** text field. The name of the macro should be descriptive of what option is being performed.

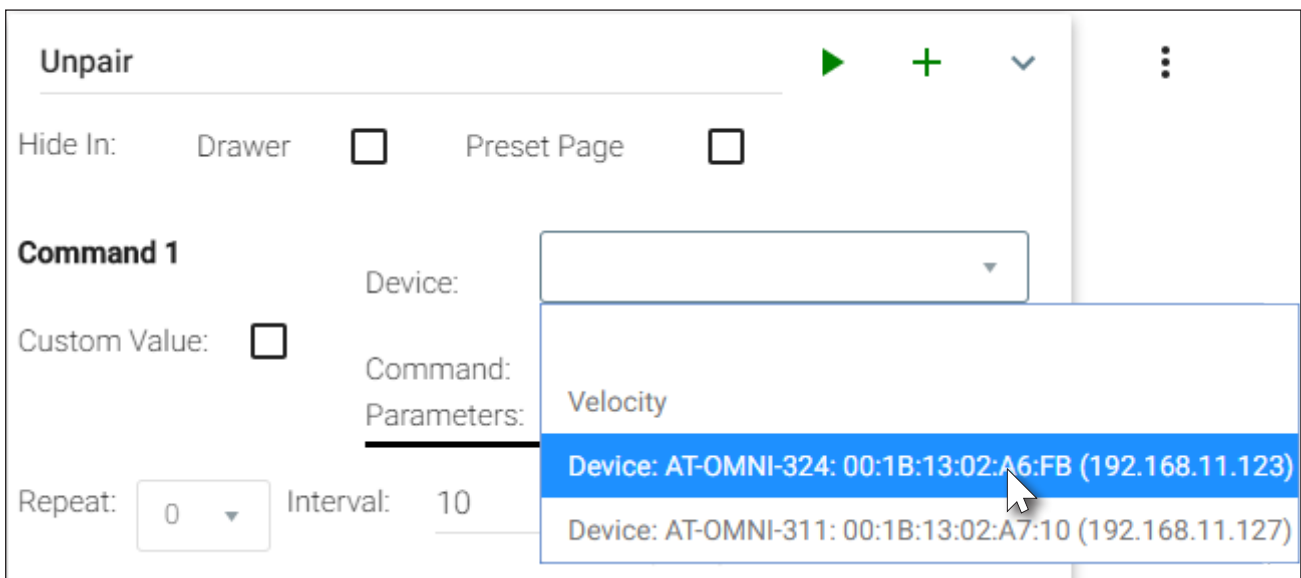

3. Click the **+** icon to display the macro configuration dialog.

4. Click the **Device** drop-down list and select one of the device from this list. Since the “Unpair” macro will disconnect the two units from one another, either the AT-OMNI-311 or AT-OMNI-324 can be selected from this drop-down list. In this example, the AT-OMNI-324 is selected.

Creating the Pair Macro

- Click the **Command** drop-down list and select **Remove All Pairings**.

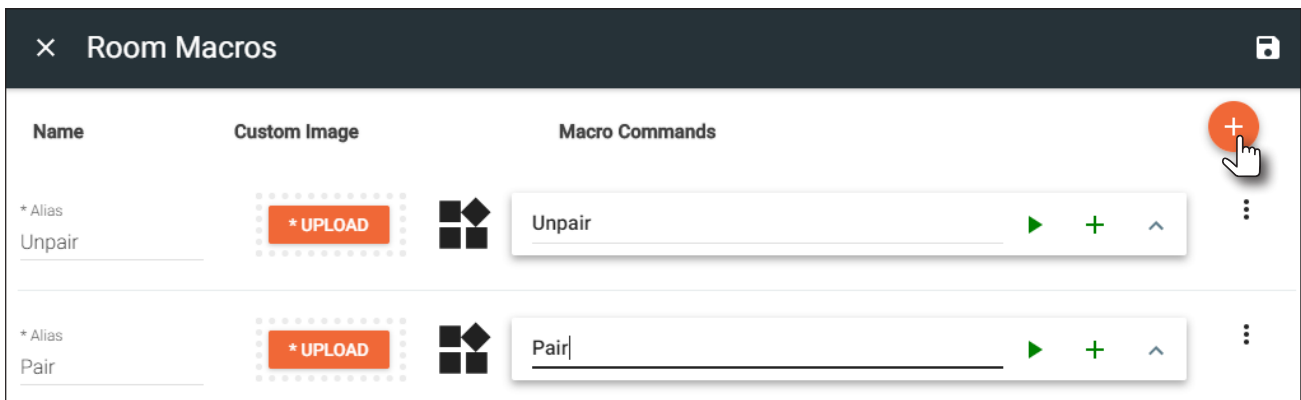

- Repeat steps 3 through 5: when repeating these steps, select the AT-OMNI-311 from the **Device** drop-down list.

- Click the **Save** icon in the top-right portion of the **Room Macros** bar.

- In the **Room Macros** screen, click the **+** icon, in the upper-right corner of the screen.
- Enter the name of the macro in both the **Name** and **Macro Commands** text field. In this example, “Pair” will be used.
- Click the **+** icon to display the macro configuration dialog.

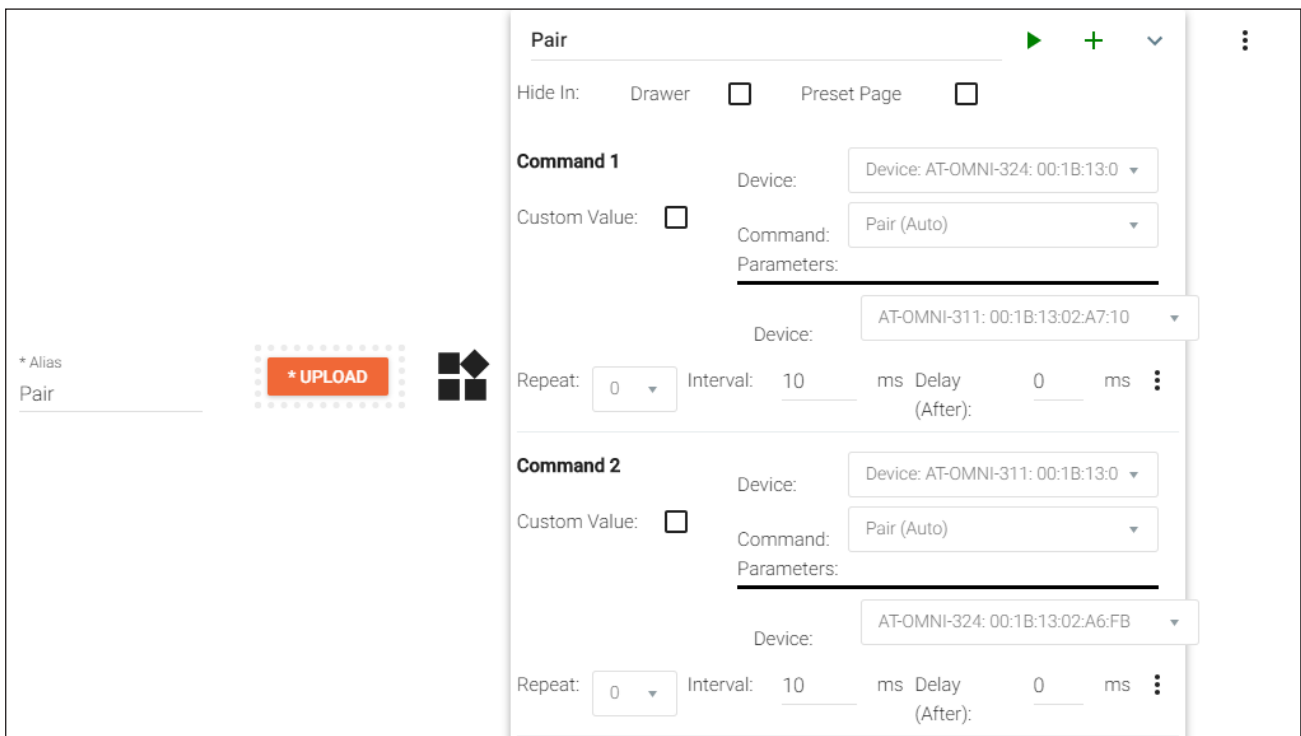

- Click the **Device** drop-down list and select the AT-OMNI-324.
- Click the **Command** drop-down list and select **Pair (Auto)**.

Basic Operation

6. Click the second **Device** drop-down list and select the unit to be paired. Since the AT-OMNI-324 was already selected, select the AT-OMNI-311 from the drop-down list.
7. Repeat steps 2 through 5: For the first **Device** drop-down list, select the AT-OMNI-324, and for the second **Device** drop-down list, select the AT-OMNI-311. When this macro is completed, it should appear similar to the following:
8. Click the **Save** icon, in the top-right portion of the **Room Macros** bar.

Pairing and Unpairing Units

IMPORTANT: Before pairing units, make sure to unpair (remove) any existing pairings using the “unpair” macro that was created on page 19.

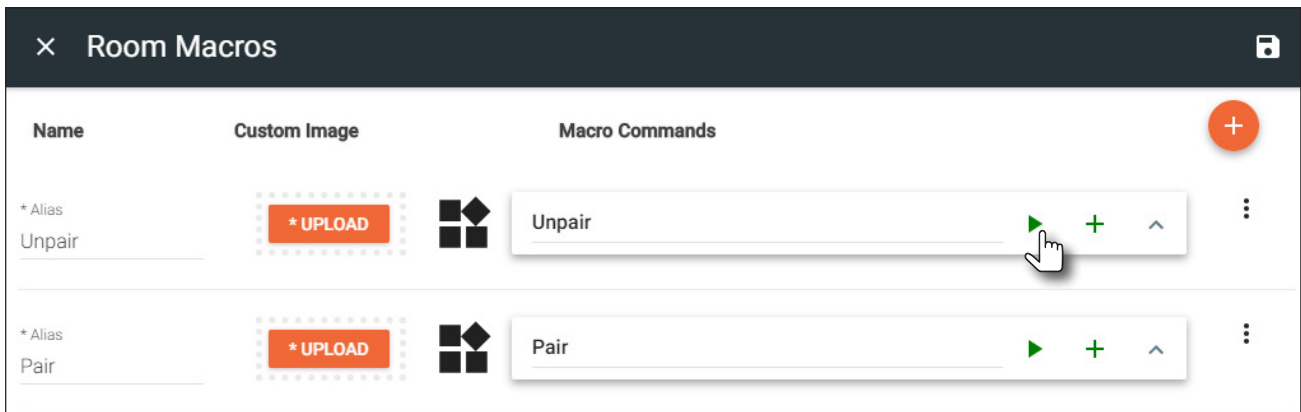

1. Click the ▶ icon for the “Unpair” macro. This will remove any possible “out-of-the-box” (factory) pairing that may exist.
2. Click the ▶ icon for the “Pair” macro to pair the two units.

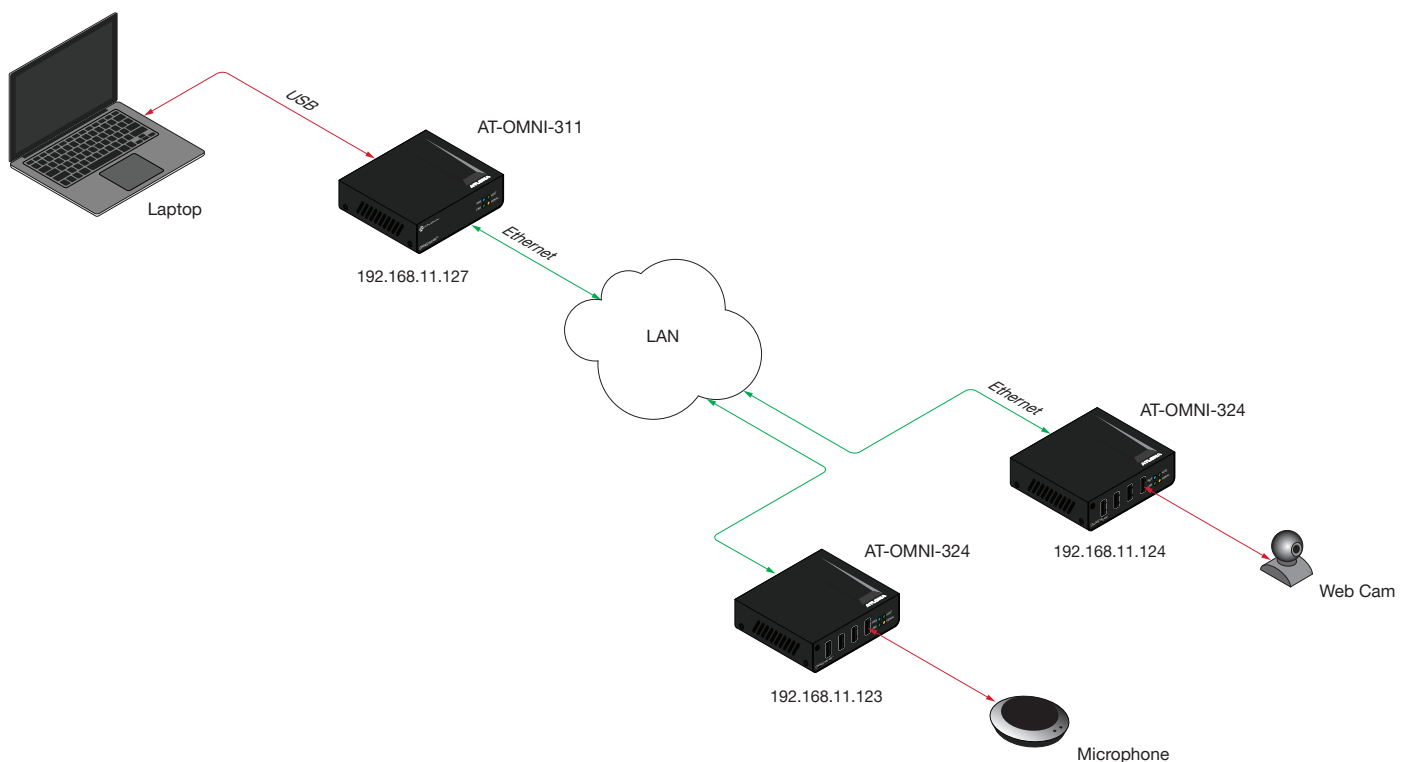

Example: Pairing two AT-OMNI-324 to a single AT-OMNI-311

The following illustration depicts an example of how to pair two AT-OMNI-324 units to a single AT-OMNI-311. Refer to the instructions on the following page for how to configure this setup. Note that arbitrary IP addresses have been assigned for reference.



1. In the **Room Macros** screen, click the  icon, in the upper-right corner of the screen.
2. Enter “Unpair” for both the **Name** and **Macro Commands** text field.
3. Click the  icon to display the macro configuration dialog.
4. Click the **Device** drop-down list and select one of the devices from this list. Since the “Unpair” macro will be disconnecting a total of three units from one another, the “Unpair” macro will contain a total of three commands. In this example, the AT-OMNI-324 is arbitrarily selected.

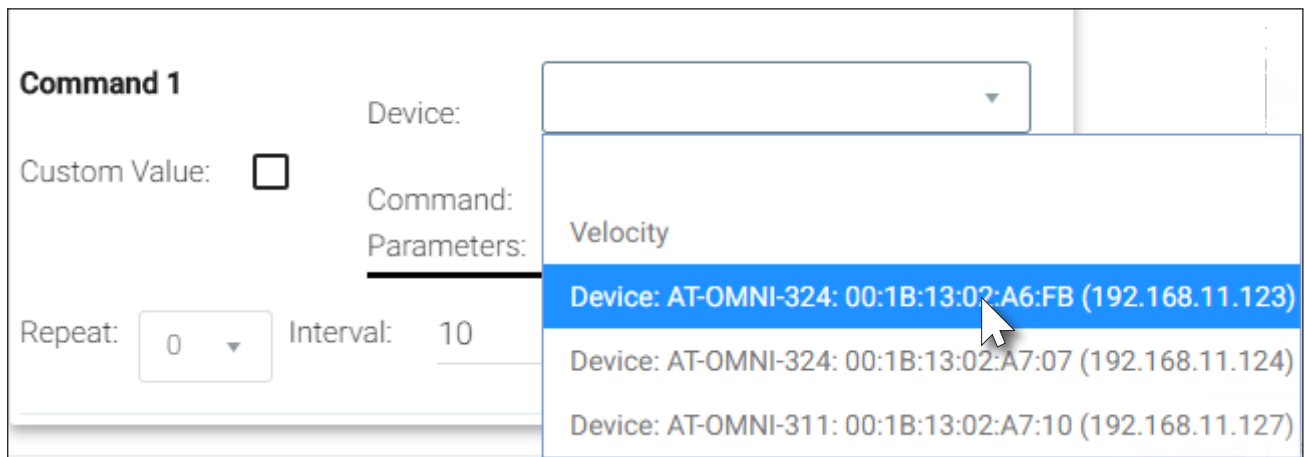

Command 1

Device: ▼

Command: **Velocity**

Parameters:

Device: AT-OMNI-324: 00:1B:13:02:A6:FB (192.168.11.123)

Device: AT-OMNI-324: 00:1B:13:02:A7:07 (192.168.11.124)

Device: AT-OMNI-311: 00:1B:13:02:A7:10 (192.168.11.127)

Custom Value:

Repeat: Interval:

5. Click the **Command** drop-down list and select **Remove All Pairings**.
6. Repeat steps 3 through 5, selecting the second AT-OMNI-324 and then the AT-OMNI-311 from the **Device** drop-down list. When completed, the “Unpair” macro should appear as follows:

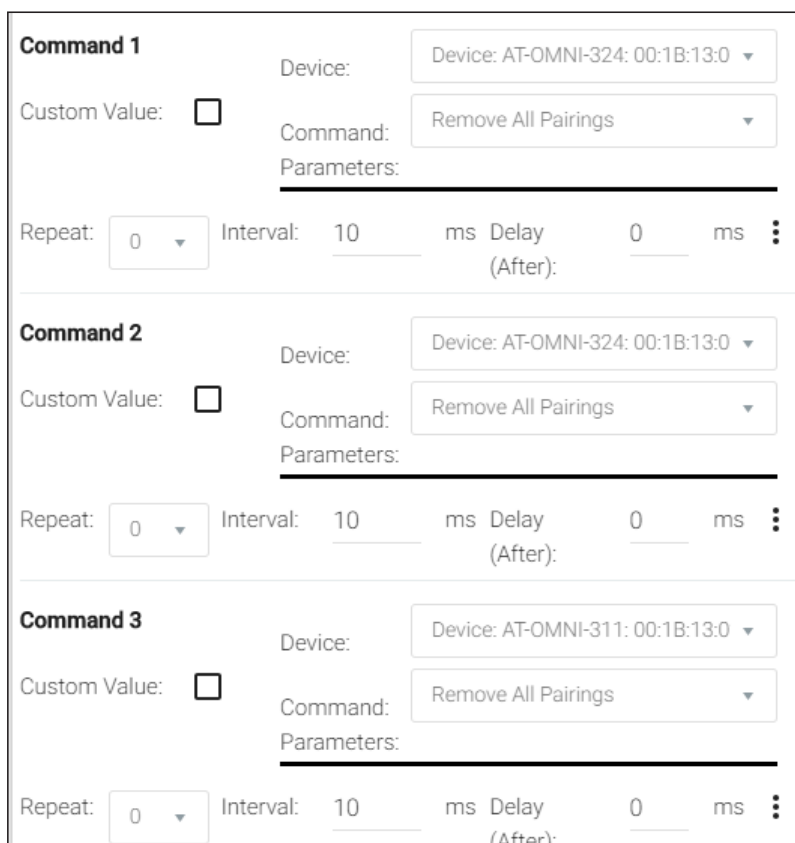

Command 1

Device: Device: AT-OMNI-324: 00:1B:13:0 ▼

Command: Remove All Pairings ▼

Parameters:

Repeat: Interval: ms Delay ms ⋮
(After):

Command 2

Device: Device: AT-OMNI-324: 00:1B:13:0 ▼

Command: Remove All Pairings ▼

Parameters:

Repeat: Interval: ms Delay ms ⋮
(After):

Command 3

Device: Device: AT-OMNI-311: 00:1B:13:0 ▼

Command: Remove All Pairings ▼

Parameters:

Repeat: Interval: ms Delay ms ⋮
(After):

7. Click the **Save** icon in the top-right portion of the **Room Macros** bar.
8. Create a “pairing” macro by clicking the  icon, in the upper-right corner of the screen.

Note that since there are two AT-OMNI-324 units, creating the “Pair” macro can be achieved using two different methods:

- a. Create two separate macros: one to pair the AT-OMNI-311 and the AT-OMNI-324 with the camera, and another one to pair the AT-OMNI-311 with the AT-OMNI-324 with the speakerphone. This method provides more control, providing the option of which AT-OMNI-324 is paired with the AT-OMNI-311.
- b. Create a single macro which pairs both AT-OMNI-324 units to the AT-OMNI-311. This method is more convenient, but does not provide the option of which AT-OMNI-324 is paired with the AT-OMNI-311.

For this example, two separate pairing macros will be created:

9. Enter “Pair to camera” in both the **Name** and **Macro Commands** text field. This macro will be used to pair the computer with the camera.
10. Click the  icon to display the macro configuration dialog.
11. Click the **Device** drop-down list and select the AT-OMNI-324 that is connected to the camera. In this example, the AT-OMNI-324 with the IP address of 192.168.11.124 will be selected.
12. Click the **Command** drop-down list and select **Pair (Auto)**.
13. Click the second **Device** drop-down list and select the AT-OMNI-311.
14. Repeat steps 10 through 13: select the AT-OMNI-311 in the first **Device** drop-down list, and then the AT-OMNI-324 with the camera, from the second **Device** drop-down list. The “Pair to camera” macro should now appear as follows:

Pair to camera ▶ + ▾

Hide In: Drawer Preset Page

Command 1

Custom Value:

Device:

Command:

Parameters: _____

Device:

Repeat: Interval: ms Delay ms ⋮

(After):

Command 2

Custom Value:

Device:



Command:

Parameters: _____



Device:

Repeat: Interval: ms Delay ms ⋮

(After):

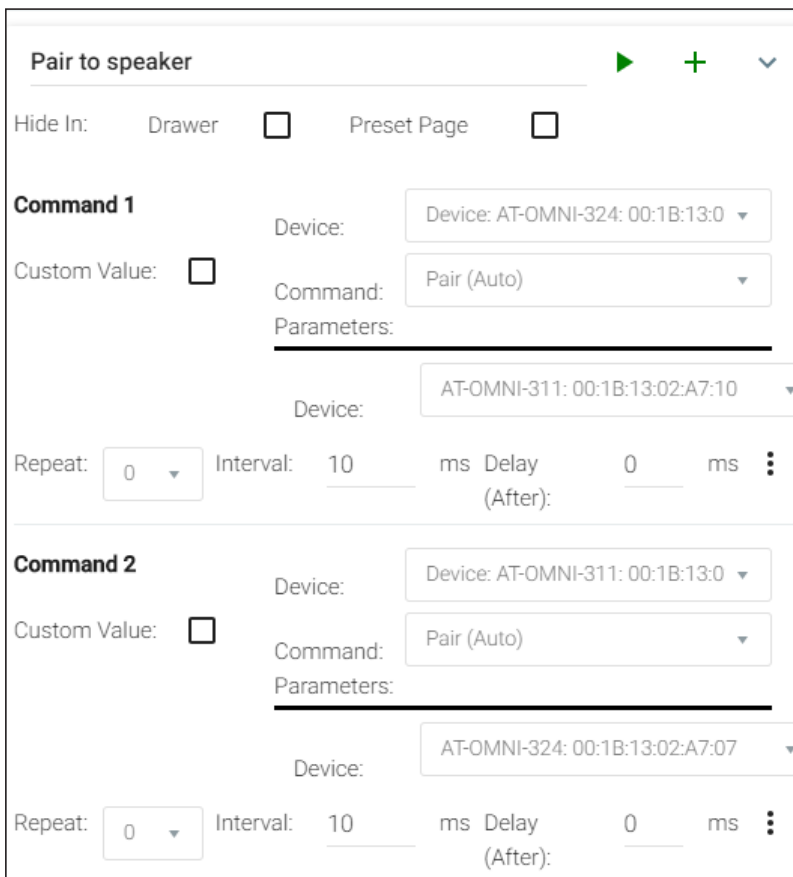
15. Click the **Save** icon in the top-right portion of the **Room Macros** bar.
16. Click the  icon, in the upper-right corner of the screen to create the final macro. This macro will be used to pair the computer with the speakerphone.
17. Enter “Pair to speaker” in both the **Name** and **Macro Commands** text field.
18. Click the  icon to display the macro configuration dialog.
19. Click the **Device** drop-down list and select the AT-OMNI-324 that is connected to the speakerphone. The AT-OMNI-324 with the IP address of 192.168.11.123 will be selected
20. Click the **Command** drop-down list and select **Pair (Auto)**.
21. Click the second **Device** drop-down list and select the AT-OMNI-311.
22. Repeat steps 18 through 21: select the AT-OMNI-311 in the first **Device** drop-down list, and then the AT-OMNI-324 with the speakerphone, from the second **Device** drop-down list. The “Pair to speaker” macro should now appear as follows:



Pair to speaker   

Hide In: Drawer Preset Page

Command 1

Custom Value:

Device:

Command:

Parameters: _____

Device:

Repeat: Interval: ms Delay ms 

(After): _____

Command 2

Custom Value:

Device:

Command:

Parameters: _____

Device:

Repeat: Interval: ms Delay ms 

(After): _____

23. Click the **Save** icon in the top-right portion of the **Room Macros** bar.

DHCP Reset

Use the following instructions to reset the device to DHCP mode. Resetting to DHCP mode will not remove any pairings and if the device is already paired, it will remain paired.

1. Disconnect power from the unit.
2. Reconnect power to the unit, and within 5 seconds, press and hold the **PAIRING** button.



3. Continue holding the **PAIRING** button for 15 seconds, then release.
4. Power-cycle the unit once again, by disconnecting and reconnecting the power. Let the unit boot up normally.
5. The unit is now in DHCP mode and will automatically be assigned an IP address by the DHCP server, if one is present on the network.

Appendix

Specifications

USB	
Signal	2.0
Maximum Data Rate	480 Mbps

Distance	Feet	Meters
Per hop of Ethernet cable	330	100

Connectors, Controls, and Indicators	
USB	1 - Type B, 4-pin female
LAN	1 - RJ45, shielded
UTILITY	1 - 3.5 mm mini-stereo
PAIRING	1 - Push button, tact-type, recessed
PWR indicator	1 - LED, green
LINK indicator	1 - LED, green
HOST indicator	1 - LED, green
SIGNAL indicator	1 - LED, green

Temperature	Fahrenheit	Celsius
Operating	32 to 122	0 to 50
Storage	-20 to 70	-4 to 158

Humidity	
Operating (RH)	20% to 80% (non-condensing)
Storage (RH)	10% to 90% (non-condensing)

Power	
Supply	Powered by USB host device

Dimensions	Inches	Millimeters
H x W x D	1.04 x 3.92 x 3.01	26.40 x 99.50 x 76.45

Weight	Pounds	Kilograms
Device	0.50	0.23

Certifications	
Device	CE, FCC, CB, RoHS

Warranty	
Device	To view the product warranty, use the following link: https://atlona.com/warranty

