



Soft Codec Conferencing System



AT-UHD-HDVS-300-KIT

Atlona Manuals
Switchers

Version Information

Version	Release Date	Notes
1	01/16	Initial release
2	02/18	New manual format

Welcome to Atlona!

Thank you for purchasing this Atlona product. We hope you enjoy it and will take an extra few moments to register your new purchase.

Registration only takes a few minutes and protects this product against theft or loss. In addition, you will receive notifications of product updates and firmware. Atlona product registration is voluntary and failure to register will not affect the product warranty.

To register your product, go to <http://www.atlona.com/registration>

Sales, Marketing, and Customer Support

Main Office

Atlona Incorporated
70 Daggett Drive
San Jose, CA 95134
United States

Office: +1.877.536.3976 (US Toll-free)
Office: +1.408.962.0515 (US/International)

Sales and Customer Service Hours
Monday - Friday: 6:00 a.m. - 4:30 p.m. (PST)

<http://www.atlona.com/>

International Headquarters

Atlona International AG
Ringstrasse 15a
8600 Dübendorf
Switzerland

Office: +41 43 508 4321

Sales and Customer Service Hours
Monday - Friday: 09:00 - 17:00 (UTC +1)

Operating Notes



IMPORTANT: Visit <http://www.atlona.com/product/AT-UHD-HDVS-300-KIT> for the latest firmware updates and User Manual.

Atlona, Inc. (“Atlona”) Limited Product Warranty

Coverage

Atlona warrants its products will substantially perform to their published specifications and will be free from defects in materials and workmanship under normal use, conditions and service.

Under its Limited Product Warranty, Atlona, at its sole discretion, will either:

- repair or facilitate the repair of defective products within a reasonable period of time, restore products to their proper operating condition and return defective products free of any charge for necessary parts, labor and shipping.

OR

- replace and return, free of charge, any defective products with direct replacement or with similar products deemed by Atlona to perform substantially the same function as the original products.

OR

- refund the pro-rated value based on the remaining term of the warranty period, not to exceed MSRP, in cases where products are beyond repair and/or no direct or substantially similar replacement products exist.

Repair, replacement or refund of Atlona products is the purchaser’s exclusive remedy and Atlona liability does not extend to any other damages, incidental, consequential or otherwise.

This Limited Product Warranty extends to the original end-user purchaser of Atlona products and is non-transferrable to any subsequent purchaser(s) or owner(s) of these products.

Coverage Periods

Atlona Limited Product Warranty Period begins on the date of purchase by the end-purchaser. The date contained on the end-purchaser’s sales or delivery receipt is the proof purchase date.

Limited Product Warranty Terms – New Products

- 10 years from proof of purchase date for hardware/electronics products purchased on or after June 1, 2013.
- 3 years from proof of purchase date for hardware/electronics products purchased before June 1, 2013.
- Lifetime Limited Product Warranty for all cable products.

Limited Product Warranty Terms – Refurbished (B-Stock) Products

- 3 years from proof of purchase date for all Refurbished (B-Stock) hardware and electronic products purchased on or after June 1, 2013.

Remedy

Atlona recommends that end-purchasers contact their authorized Atlona dealer or reseller from whom they purchased their products. Atlona can also be contacted directly. Visit www.atlona.com for Atlona’s contact information and hours of operation. Atlona requires that a dated sales or delivery receipt from an authorized dealer, reseller or end-purchaser is provided before Atlona extends its warranty services. Additionally, a return merchandise authorization (RMA) and/or case number, is required to be obtained from Atlona in advance of returns.

Atlona requires that products returned are properly packed, preferably in the original carton, for shipping. Cartons not bearing a return authorization or case number will be refused. Atlona, at its sole discretion, reserves the right to reject any products received without advanced authorization. Authorizations can be requested by calling 1-877-536-3976 (US toll free) or 1-408- 962-0515 (US/international) or via Atlona’s website at www.atlona.com.

Exclusions

This Limited Product Warranty excludes:

- Damage, deterioration or malfunction caused by any alteration, modification, improper use, neglect, improper packaging or shipping (such claims must be presented to the carrier), lightning, power surges, or other acts of nature.

Atlona, Inc. (“Atlona”) Limited Product Warranty

- Damage, deterioration or malfunction resulting from the installation or removal of this product from any installation, any unauthorized tampering with this product, any repairs attempted by anyone unauthorized by Atlona to make such repairs, or any other cause which does not relate directly to a defect in materials and/or workmanship of this product.
- Equipment enclosures, cables, power supplies, batteries, LCD displays, and any accessories used in conjunction with the product(s).
- Products purchased from unauthorized distributors, dealers, resellers, auction websites and similar unauthorized channels of distribution.

Disclaimers

This Limited Product Warranty does not imply that the electronic components contained within Atlona’s products will not become obsolete nor does it imply Atlona products or their electronic components will remain compatible with any other current product, technology or any future products or technologies in which Atlona’s products may be used in conjunction with. Atlona, at its sole discretion, reserves the right not to extend its warranty offering in instances arising outside its normal course of business including, but not limited to, damage inflicted to its products from acts of god.

Limitation on Liability

The maximum liability of Atlona under this limited product warranty shall not exceed the original Atlona MSRP for its products. To the maximum extent permitted by law, Atlona is not responsible for the direct, special, incidental or consequential damages resulting from any breach of warranty or condition, or under any other legal theory. Some countries, districts or states do not allow the exclusion or limitation of relief, special, incidental, consequential or indirect damages, or the limitation of liability to specified amounts, so the above limitations or exclusions may not apply to you.

Exclusive Remedy

To the maximum extent permitted by law, this limited product warranty and the remedies set forth above are exclusive and in lieu of all other warranties, remedies and conditions, whether oral or written, express or implied. To the maximum extent permitted by law, Atlona specifically disclaims all implied warranties, including, without limitation, warranties of merchantability and fitness for a particular purpose. If Atlona cannot lawfully disclaim or exclude implied warranties under applicable law, then all implied warranties covering its products including warranties of merchantability and fitness for a particular purpose, shall provide to its products under applicable law. If any product to which this limited warranty applies is a “Consumer Product” under the Magnuson-Moss Warranty Act (15 U.S.C.A. §2301, ET SEQ.) or other applicable law, the foregoing disclaimer of implied warranties shall not apply, and all implied warranties on its products, including warranties of merchantability and fitness for the particular purpose, shall apply as provided under applicable law.

Other Conditions

Atlona’s Limited Product Warranty offering gives legal rights, and other rights may apply and vary from country to country or state to state. This limited warranty is void if (i) the label bearing the serial number of products have been removed or defaced, (ii) products are not purchased from an authorized Atlona dealer or reseller. A comprehensive list of Atlona’s authorized distributors, dealers and resellers can be found at www.atlona.com.

Important Safety Information

CAUTION
RISK OF ELECTRIC SHOCK
DO NOT OPEN

CAUTION: TO REDUCT THE RISK OF
ELECTRIC SHOCK
DO NOT OPEN ENCLOSURE OR EXPOSE
TO RAIN OR MOISTURE.
NO USER-SERVICEABLE PARTS
INSIDE REFER SERVICING TO
QUALIFIED SERVICE PERSONNEL.



The exclamation point within an equilateral triangle is intended to alert the user to the presence of important operating and maintenance instructions in the literature accompanying the product.



The information bubble is intended to alert the user to helpful or optional operational instructions in the literature accompanying the product.

1. Read these instructions.
2. Keep these instructions.
3. Heed all warnings.
4. Follow all instructions.
5. Do not use this product near water.
6. Clean only with a dry cloth.
7. Do not block any ventilation openings. Install in accordance with the manufacturer's instructions.
8. Do not install or place this product near any heat sources such as radiators, heat registers, stoves, or other apparatus (including amplifiers) that produce heat.
9. Do not defeat the safety purpose of a polarized or grounding-type plug. A polarized plug has two blades with one wider than the other. A grounding type plug has two blades and a third grounding prong. The wide blade or the third prong are provided for your safety. If the provided plug does not fit into your outlet, consult an electrician for replacement of the obsolete outlet.
10. Protect the power cord from being walked on or pinched particularly at plugs, convenience receptacles, and the point where they exit from the product.
11. Only use attachments/accessories specified by Atlona.
12. To reduce the risk of electric shock and/or damage to this product, never handle or touch this unit or power cord if your hands are wet or damp. Do not expose this product to rain or moisture.
13. Unplug this product during lightning storms or when unused for long periods of time.
14. Refer all servicing to qualified service personnel. Servicing is required when the product has been damaged in any way, such as power-supply cord or plug is damaged, liquid has been spilled or objects have fallen into the product, the product has been exposed to rain or moisture, does not operate normally, or has been dropped.



FCC Statement

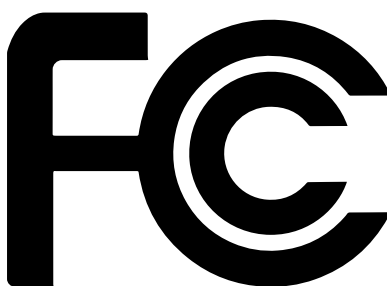

FCC Compliance and Advisory Statement: This hardware device complies with Part 15 of the FCC rules. Operation is subject to the following two conditions: 1) this device may not cause harmful interference, and 2) this device must accept any interference received including interference that may cause undesired operation. This equipment has been tested and found to comply with the limits for a Class A digital device, pursuant to Part 15 of the FCC Rules. These limits are designed to provide reasonable protection against harmful interference in a commercial installation.

This equipment generates, uses, and can radiate radio frequency energy and, if not installed or used in accordance with the instructions, may cause harmful interference to radio communications. However there is no guarantee that interference will not occur in a particular installation. If this equipment does cause harmful interference to radio or television reception, which can be determined by turning the equipment off and on, the user is encouraged to try to correct the interference by one or more of the following measures: 1) reorient or relocate the receiving antenna; 2) increase the separation between the equipment and the receiver; 3) connect the equipment to an outlet on a circuit different from that to which the receiver is connected; 4) consult the dealer or an experienced radio/TV technician for help. Any changes or modifications not expressly approved by the party responsible for compliance could void the user's authority to operate the equipment. Where shielded interface cables have been provided with the product or specified additional components or accessories elsewhere defined to be used with the installation of the product, they must be used in order to ensure compliance with FCC regulations.

Table of Contents

Introduction	8
Features	8
Package Contents	8
Panel Description	9
Transmitter	9
Receiver	10
Installation	11
RS-232	11
Power	11
Connection Instructions	12
Transmitter	12
Receiver	12
Connection Diagram	13
IP Configuration	14
Using the Front Panel	14
Using Commands	15
Using the Web GUI	16
Basic Operation	17
USB Modes	17
Follow Video	17
Follow USB	21
Manual	22
RS-232 Control	23
Pass-through mode	23
Control mode	25
The Web GUI	29
Introduction to the Web GUI	29
Menu Bar	30
Status page	31
Firmware page	32
Network page	33
Control page	34
Users page	35
EDID page	36
Settings page	38
Setup page	39
Command page	41
Appendix	43
Updating the Firmware	43
Cable Termination	45
Default Settings	46
Specifications	47
Index	49

Introduction

The Atlona **AT-UHD-HDVS-300-KIT** provides AV switching, USB and HDMI extension, plus integrated system control for huddle spaces and meeting rooms using PC-based conferencing codecs such as Skype® for Business, WebEx®, and GoToMeeting®. The transmitter and receiver kit offers five video inputs for HDMI, DisplayPort, and analog video signals. To simplify conference room device management, the kit provides two USB type B connectors for host computers. Two built-in USB hubs, one on the transmitter and one on the receiver, allow for numerous Human Interface Devices (HID) as well as USB cameras, microphones, and speakerphones. For the HDMI inputs, the HDVS-300-KIT is compatible with sources and displays up to 4K/UHD @ 60 Hz with 4:2:0 color subsampling. Audio, video, data, control, USB, and Ethernet transmission between the two devices is carried over a single, Ethernet-enabled HDBaseT link up to 330 feet (100 meters).

Features

- Integrates PCs and touch displays as well as USB cameras, mics, and speakerphones for presentations and teleconferences
- AV switcher with USB hub and Ethernet-enabled, extended distance HDBaseT extension
- Receiver with additional HDMI input, USB hub, and PoE
- Bidirectional USB 2.0* extension between conference table and display
- Automatic display control
- Automatic input selection using video detection technology
- EDID management and HDCP management
- 4K/UHD capability**
- AV, Ethernet, USB, power and control over HDBaseT
- Power over Ethernet for remotely powering the transmitter
- Ethernet control
- Easy, GUI-based configuration using integrated web server
- Multichannel audio compliant
- Rack-mountable, 1U, half-rack width enclosure (TX only)
- Works with AMS
- Award-winning 10-year limited product warranty

* Maximum 170 Mbps data rate supported over HDBaseT.

** 4K/UHD capability is supported through the HDMI inputs. The DisplayPort input accepts signals up to 1080p resolution.

Package Contents

- 1 x AT-UHD-HDVS-300-TX
- 1 x AT-UHD-HDVS-300-RX
- 2 x Captive screw connector, 3-pin
- 2 x Mounting plates
- 2 x Mounting brackets
- 4 x Rubber feet
- 1 x 48 V DC power supply
- 1 x Installation Guide

Panel Description

Transmitter

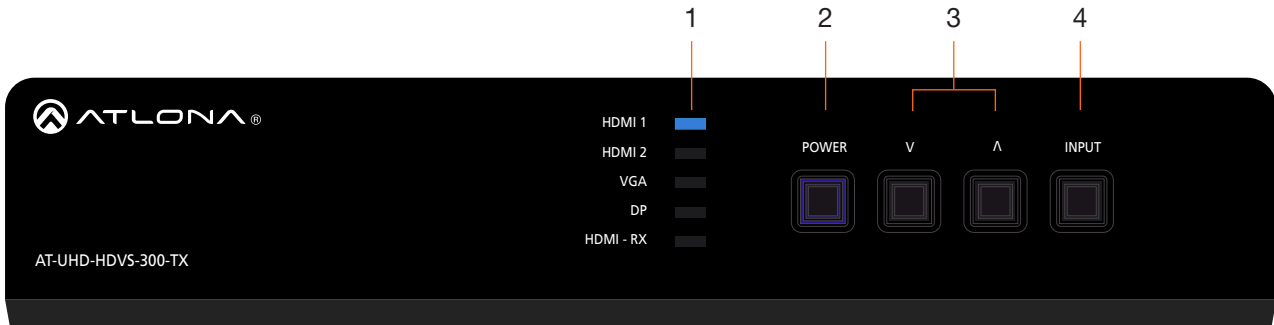

Front

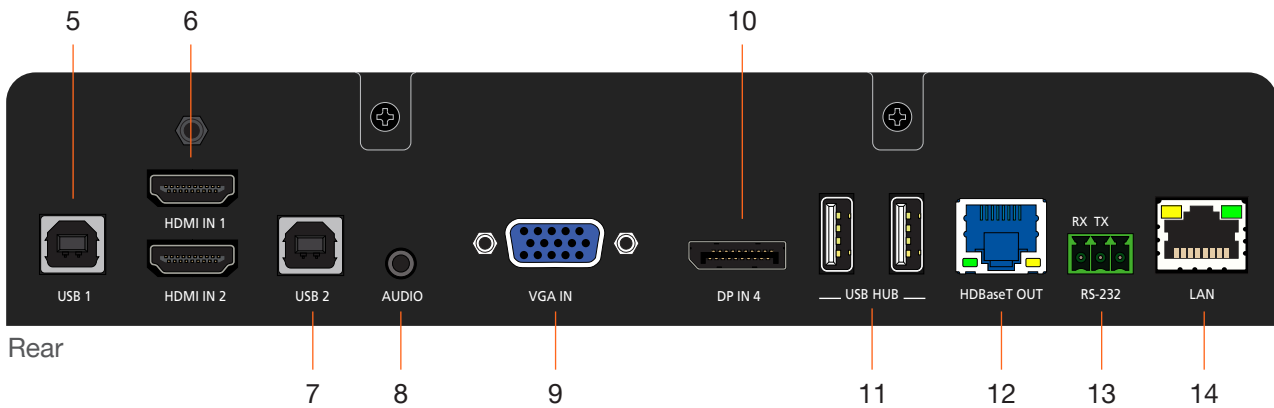

Rear

1 Input Indicators

Displays the currently selected input.

2 POWER

Press this button to cycle through each input.

3 Cursor Buttons

Adjusts the volume on the display. Pressing both buttons, simultaneously, will mute the volume.

4 INPUT

Press this button to toggle the power state of the desired display.

5 USB 1

Connect a USB-A/B cable from this port to a host USB device.

6 HDMI IN 1 / HDMI IN 2

Connect up to two HD/UHD sources to these ports using HDMI cables.

7 USB 2

Connect a USB-A/B cable from this port to a host USB device.

8 AUDIO

Connect a 3.5 mm mini-stereo cable from this port to the Line Out audio port of a computer or other line-level analog audio source.

9 VGA IN

Connect a VGA cable from this port to the VGA port on a computer.

10 DP IN 4

Connect a DisplayPort cable from this port to a DisplayPort source.

11 USB HUB

Connect up to two USB devices to these ports. These ports support both USB 2.0 and USB 1.1 devices.

12 HDBaseT OUT

Connect an Ethernet cable from this port to the receiver unit.

13 RS-232

Connect the included 3-pin captive screw connector to an automation control system. Refer to [RS-232 \(page 11\)](#) for wiring information. This port provides either RS-232 pass-through or display control. Refer to [RS-232 Control \(page 23\)](#) for more information.

14 LAN

Connect an Ethernet cable from this port to the network.

Receiver

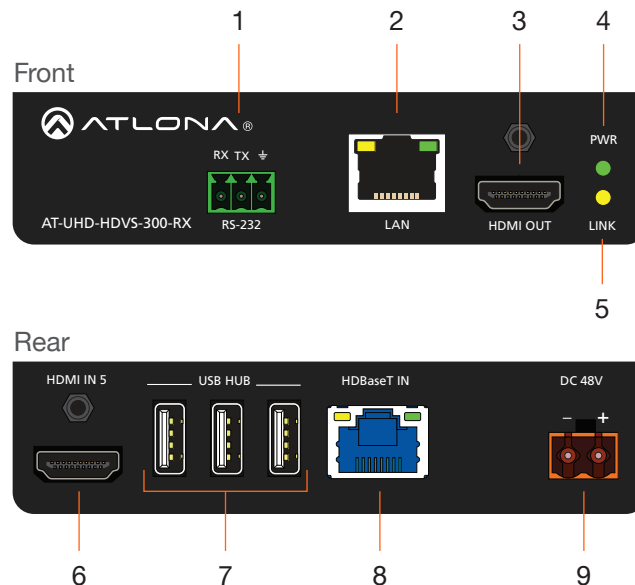

- 1 RS-232**
Connect the included 3-pin captive screw connector to the RS-232 device to be controlled. Refer to [RS-232 \(page 11\)](#) for wiring information.
- 2 LAN**
Connect an Ethernet cable from this port to the network.
- 3 HDMI OUT**
Connect an HDMI cable from this port to an HD/UHD display.
- 4 PWR**
This LED indicator will glow bright green when the unit is powered.
- 5 LINK**
This LED indicator will glow bright amber when a solid link has been established, between the transmitter and the receiver.
- 6 HDMI IN 5**
Connect a HD/UHD source to this port using an HDMI cable.
- 7 USB HUB**
Connect up to three USB devices to these ports. These ports support both USB 2.0 and USB 1.1 devices.
- 8 HDBaseT IN**
Connect an Ethernet cable from this port to the transmitter.
- 9 DC 48V**
Connect the included power supply to this port using the included 2-pin captive screw connector. Refer to [Power \(page 11\)](#) for wiring information.

Installation

RS-232

The AT-UHD-HDVS-300-TX provides RS-232 control between an automation system and an RS-232 device or display control. This step is optional. Refer to [RS-232 Control \(page 23\)](#) for more information.

1. Use wire strippers to remove a portion of the cable jacket.
2. Remove at least 3/16" (5 mm) from the insulation of the RX, TX, and GND wires.
3. Insert the TX, RX, and GND wires into correct terminal on the included captive screw connector block.

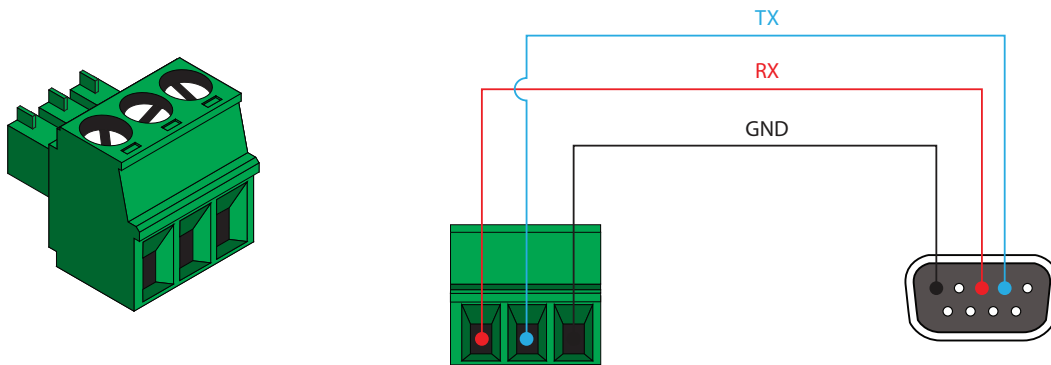

Power

Locate the included orange 2-pin captive screw terminal block and wire the included captive screw terminal block, as shown below. Do not use high-torque devices, when securing the wires to the terminal block, as this may damage the screws and/or the block.

1. Insert the wires into the correct terminal on the included captive screw terminal block, as shown below.
2. Tighten the screws to secure the wires. Do not use high-torque devices as this may damage the screws and/or terminal block.

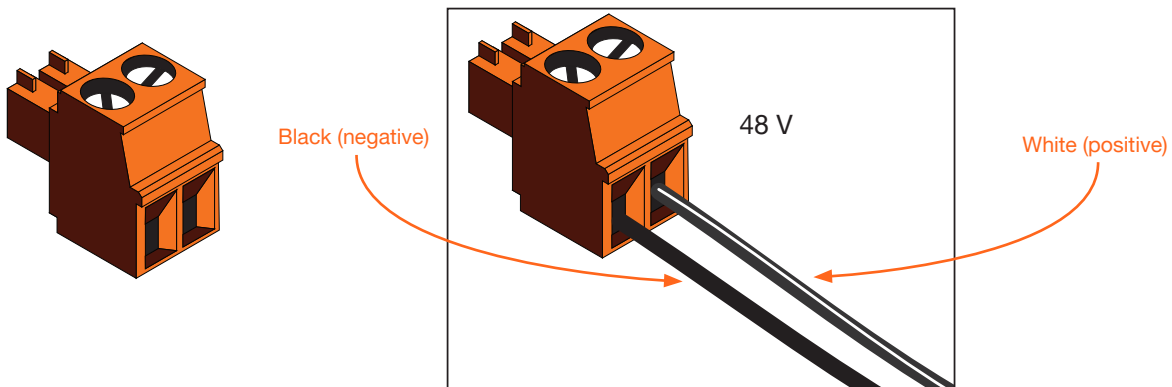

Connection Instructions

Transmitter

1. Connect up to two UHD/HD sources to the **HDMI IN 1** and **HDMI IN 2** ports.
2. Connect a VGA source to the **VGA IN** port.
3. Connect up to two USB host devices to the **USB 1** and **USB 2** ports, using USB A/B cables. Both USB 1.1 and USB 2.0 are supported.
4. OPTIONAL: Connect a 3.5 mm mini-stereo cable from the **AUDIO** port to an analog audio source. Making this connection will allow audio to accompany the source connected to **VGA IN**.
5. OPTIONAL: Connect the included 3-pin captive screw connector block from the **RS-232** port to an automation control device. This port provides pass-through control of the RS-232 device connected to the AT-UHD-HDVS-300-RX.
6. Connect up to two USB devices (e.g. keyboard, mouse device, etc.) to the **USB HUB** ports. Both USB 1.1 and USB 2.0 are supported. Maximum current draw for this hub is 1.5 A. Maximum current draw for both transmitter and receiver is 2.5 A.
7. Connect an Ethernet cable from the **HDBaseT OUT** port to the **HDBaseT IN** port on the AT-UHD-HDVS-300-RX. Ethernet cables should use EIA/TIA-568B termination.
8. Connect an Ethernet cable, up to 330 feet (100 meters), from the **LAN** port to the Local Area Network (LAN). An automation control system can also be connected to the network, allowing pass-through IP control to an IP-controlled device connected to the AT-UHD-HDVS-300-RX. Connecting this port to the LAN will also provide access to the built-in web GUI. Refer to [The Web GUI \(page 29\)](#) for more information. Ethernet cables should use EIA/TIA-568B termination.

Receiver

1. Connect an HDMI cable from the **HDMI OUT** port to a UHD/HD display.
2. Connect an HDMI cable from the **HDMI IN 5** port to a UHD/HD source.
3. OPTIONAL: Connect the included 3-pin captive screw connector block from the **RS-232** port to an RS-232 device. This port provides both pass-through control from the automation control system, connected to the AT-UHD-HDVS-300-TX, or display control to the device connected to the AT-UHD-HDVS-300-RX.
4. Connect up to three USB devices (e.g. keyboard, mouse device, etc.) to the **USB HUB** ports. Both USB 1.1 and USB 2.0 are supported. Maximum current draw for this hub is 1.5 A. Maximum current draw for both transmitter and receiver is 2.5 A.
5. Connect an Ethernet cable from the **HDBaseT IN** port to the **HDBaseT OUT** port on the AT-UHD-HDVS-300-TX. Ethernet cables should use EIA/TIA-568B termination.
6. Connect an Ethernet cable, up to 330 feet (100 meters), from the **LAN** port to the Local Area Network (LAN). An automation control system can also be connected to the network, allowing pass-through IP control to an IP-controlled device connected to the AT-UHD-HDVS-300-RX. Connecting this port to the LAN will also provide access to the built-in web GUI. Refer to [The Web GUI \(page 29\)](#) for more information. Ethernet cables should use EIA/TIA-568B termination.
7. Connect the included power supply to this port using the included 2-pin captive screw connector. Refer to [Power \(page 11\)](#) for wiring information.

Connection Diagram

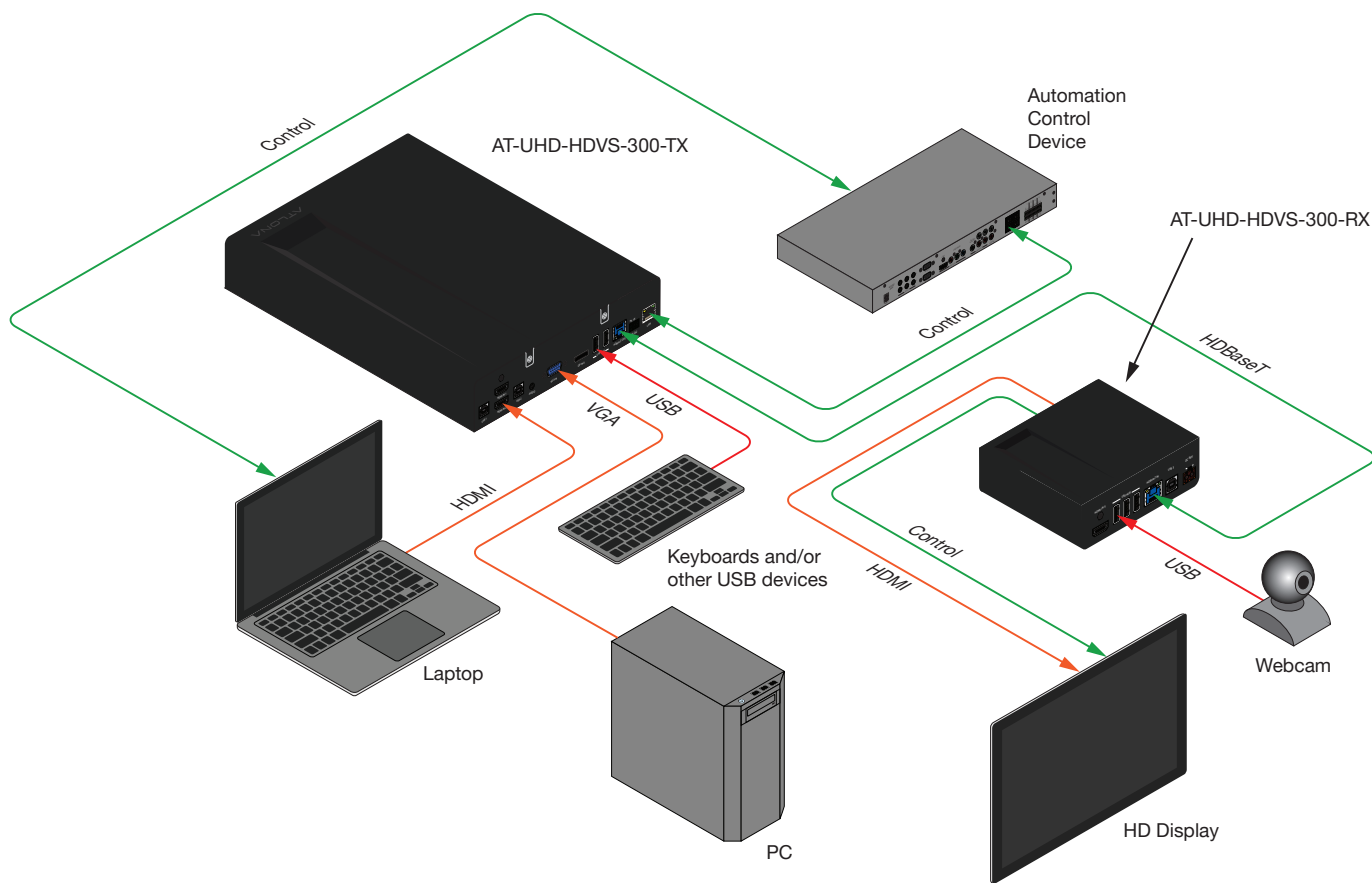

IP Configuration

The AT-UHD-HDVS-300-KIT is shipped with DHCP enabled. Once connected to a network, the DHCP server (if available), will automatically assign an IP address to the unit. Execute the `arp -a` command at the Windows command line or use an IP scanner to locate the AT-UHD-HDVS-300-KIT on the network.

If the AT-UHD-HDVS-300-KIT is unable to detect a DHCP server, within 15 seconds, then the unit will be assigned the following.

- IP address 192.168.1.254
- Subnet mask 255.255.0.0
- Gateway 192.168.1.1

If a static IP address is desired, the unit can be switched to static IP mode. Use one of the following procedures to switch between DHCP and static IP mode. 192.168.1.254 is the default static IP address.

Using the Front Panel

1. Make sure the AT-UHD-HDVS-300-TX is powered.
2. Press and hold the **INPUT** button for approximately 10 seconds.

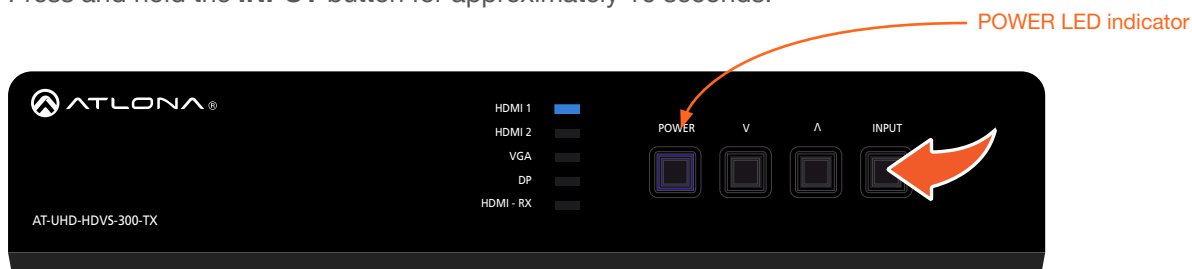

3. Release the **INPUT** button once the **POWER** LED indicator begins to flash. The number of flashes will indicate the currently selected IP mode.

POWER LED flashes	Description
Two	Static IP mode
Four	DHCP mode

4. Once the unit has changed IP modes, the unit will shut down. To restart the unit, the power will need to be disconnected from the AT-UHD-HDVS-300-TX then reconnected using one of the following methods:
 - Disconnect then reconnect the power from the receiver.

OR

 - Disconnect then reconnect the Ethernet cable from the **HDBaseT OUT** port on the transmitter.
5. The unit is now set to the new IP mode and ready for use.

Using Commands

Use the IPStatic and IPDHCP commands to switch between DHCP and static IP mode using Telnet. Refer to the Application Programmers Interface documentation for more information. All commands and their arguments are case-sensitive.

- **Setting static IP mode**

1. Connect to the AT-UHD-HDVS-300-TX using Telnet.
2. At the command line, execute the IPDHCP command using the off argument, as shown.

```
IPDHCP off
```

3. Execute the IPStatic command. This command requires three arguments: the desired IP address of the AT-UHD-HDVS-300-TX, the subnet mask, and the gateway address. All arguments must be entered in dot-decimal notation. The following is an example:

```
IPStatic 192.168.1.112 255.255.255.0 192.168.1.1
```

4. Power-cycle the AT-UHD-HDVS-300-TX.
5. The unit is now set to static IP mode and ready for use.

- **Setting DHCP mode**

1. Connect to the AT-UHD-HDVS-300-TX using Telnet.
2. At the command line, execute the IPDHCP command using the on argument, as shown. All characters are case-sensitive.

```
IPDHCP on
```

3. Power-cycle the AT-UHD-HDVS-300-TX.
4. The unit is now set to DHCP mode and will be assigned an IP address by the DHCP server (if present).

Using the Web GUI

The **Network page (page 33)**, in the web GUI, allows the AT-UHD-HDVS-300-TX to use either DHCP or static IP mode. In order to access the web GUI, the IP address of the AT-UHD-HDVS-300-TX must be known.

1. Open the desired web browser and enter the IP address of the AT-UHD-HDVS-300-TX.
2. Log in, using the required credentials. The factory-default username and password are listed below:

Username: root
 Password: Atlona

3. Click the **Network** tab, located on the side menu bar.

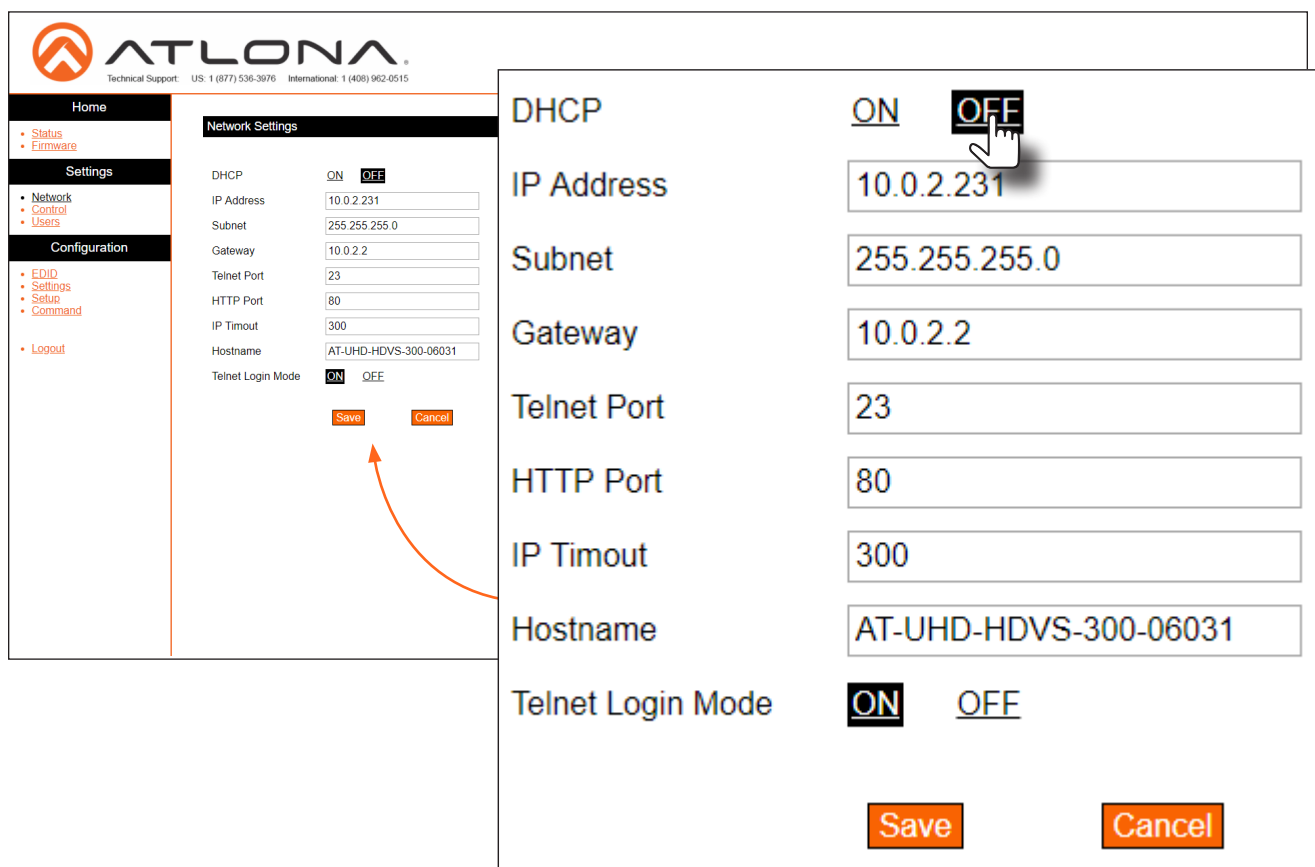

- **Setting static IP mode**
 - a. Click the **OFF** button, next to **DHCP**.
 - b. Enter the required information in the **IP Address**, **Subnet**, and **Gateway** fields.
 - **Setting DHCP mode**
 - a. Click the **ON** button, next to **DHCP**.
4. Click the **Save** button to save the changes.

Basic Operation

USB Modes

The AT-UHD-HDVS-300-TX provides three different USB modes: **Follow Video**, **Follow USB**, and **Manual**. Each mode provides different method of controlling USB, based on how the system is connected. All three modes will be covered in this section.

Follow Video

This mode is the default setting of the The AT-UHD-HDVS-300-TX. In **Follow Video** mode, each video input can be assigned to either **USB 1** or **USB 2** host ports. This mode locks the USB host device to the desired video port. In this way, the video source will have have access to all connected USB device, each time video switching occurs.

The AT-UHD-HDVS-300-TX has two USB host ports: **USB 1** and **USB 2**. Before using **Follow Video** mode, make sure that each input is assigned to the desired USB host port.



1. Connect the host computers to the desired USB host port.
2. Launch a web browser and login to the web GUI. The factory-default username and password are listed below:

Username: root
 Password: Atlona

3. Click **Setting** in the side menu bar.
4. Locate the **USB Host** section. The **Follow Video** radio button should already be enabled. The factory-default **USB Host** assignments for Input 1 through Input 5 are as follows:

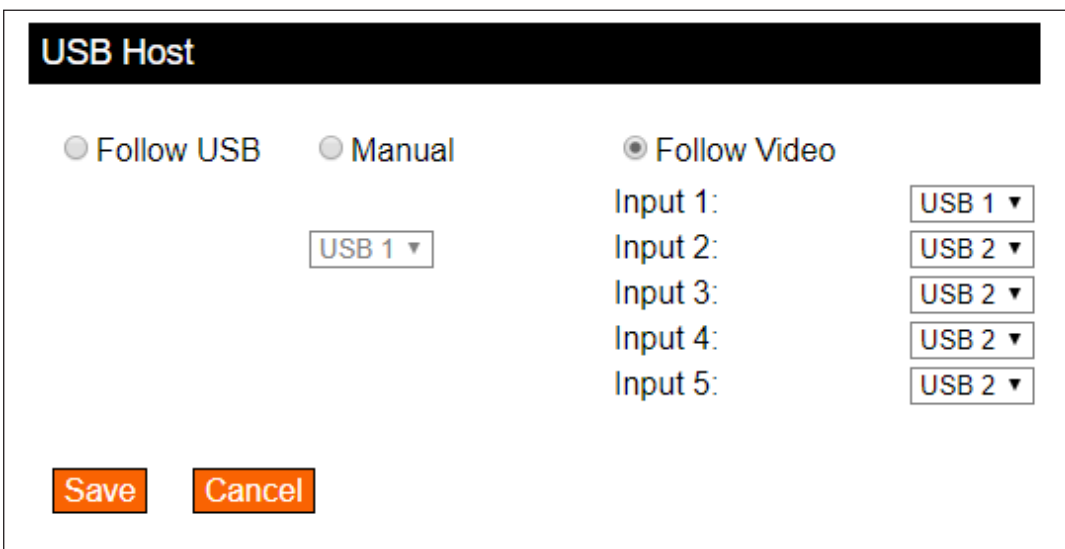

- Click the drop-down list, next to the input, to assign each input to the desired USB host port.

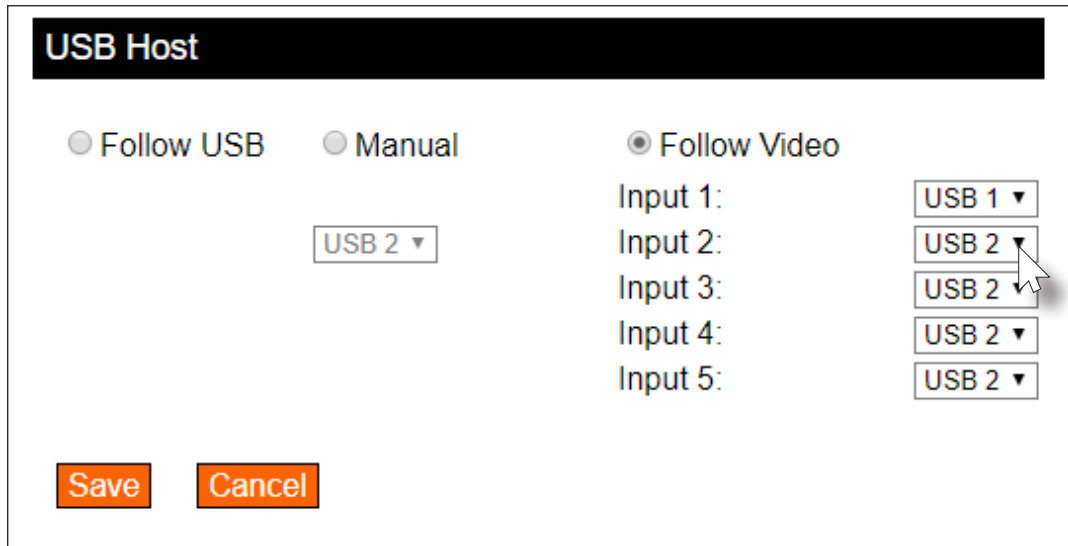

- Click the **Save** button to commit the changes or click **Cancel** to abort the changes.
- Press the **INPUT** button on the front panel and select **HDMI 1**. When HDMI 1 is selected, USB 1 will be the active USB host and will have access to all connected USB devices on the transmitter and receiver.

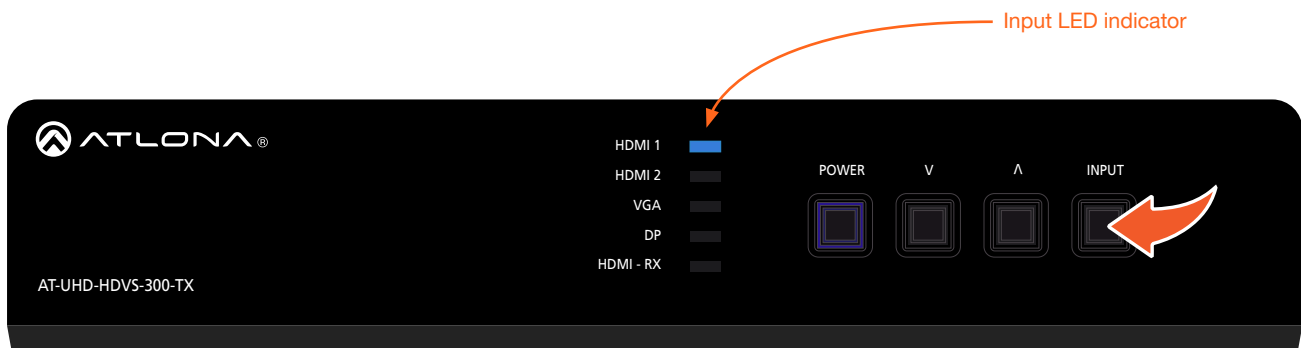

Each LED indicator on the front panel references a video input on the transmitter and receiver. The table below provides a list of these names.

Front Panel Name	Follow Video Name	Physical Input Name	Web GUI Name*
HDMI 1	Input 1	HDMI IN 1	HDMI_1
HDMI 2	Input 2	HDMI IN 2	HDMI_2
VGA	Input 3	VGA IN 3	VGA
DP	Input 4	DP IN 4	Display_Port
HDMI - RX	Input 5	HDMI IN 5	HDMI_(RX)

* Factory-default names as used in the web GUI. References to port names in the web GUI can be changed. Refer to [Settings page \(page 38\)](#) for more information.

Figure 1.1 - HDMI 1 is selected as the active video input and Laptop 1 has access to the mouse, keyboard, and camera. For purposes of clarity, the HDBaseT connection between the transmitter and receiver is not shown. Black signal lines indicate that the AT-UHD-HDVS-300 is not switched to that input.

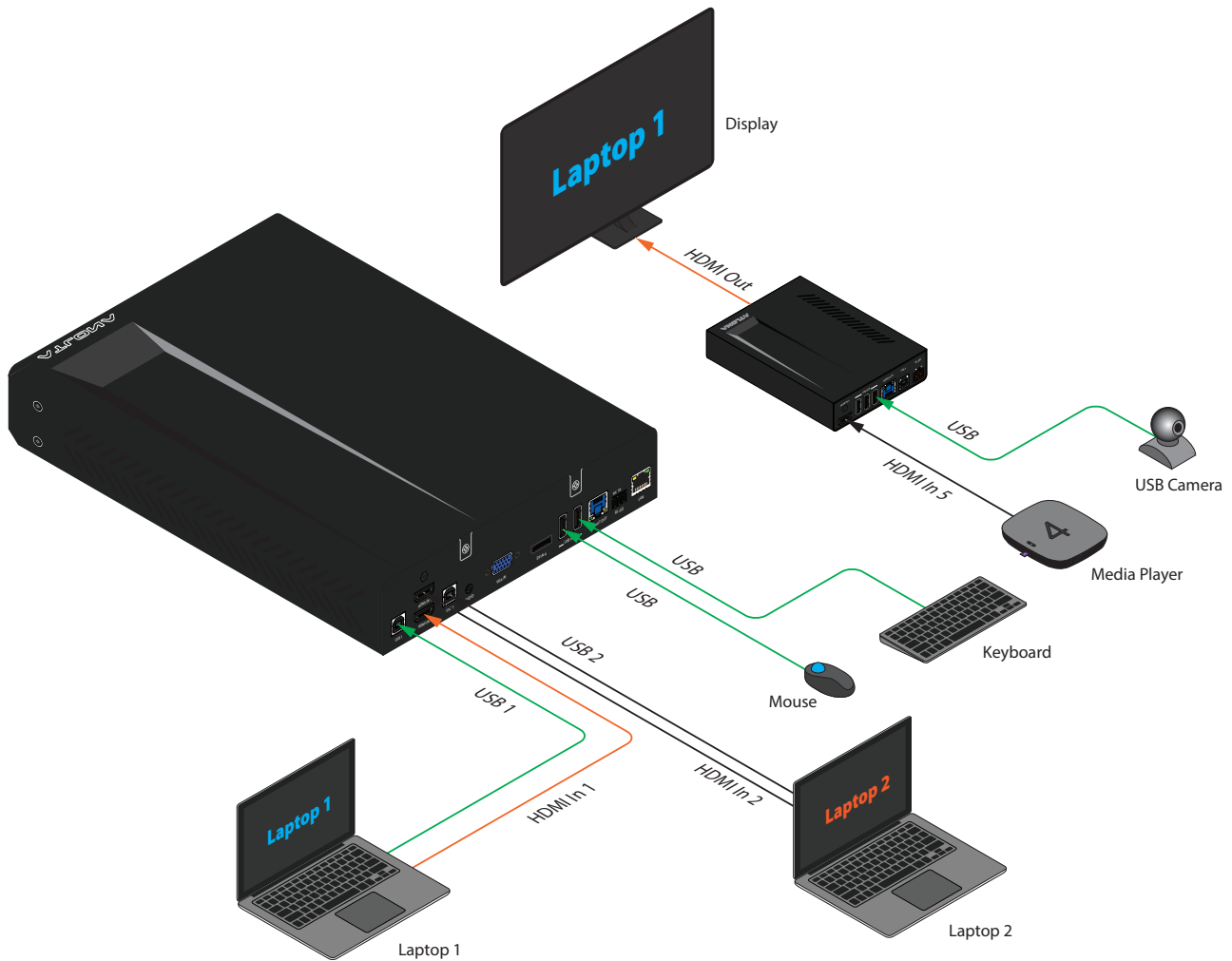

- Press the **INPUT** button on the front panel and select **HDMI 2**. When HDMI 1 is selected, USB 1 will be the active USB host and will have access to all connected USB devices on the transmitter and receiver.

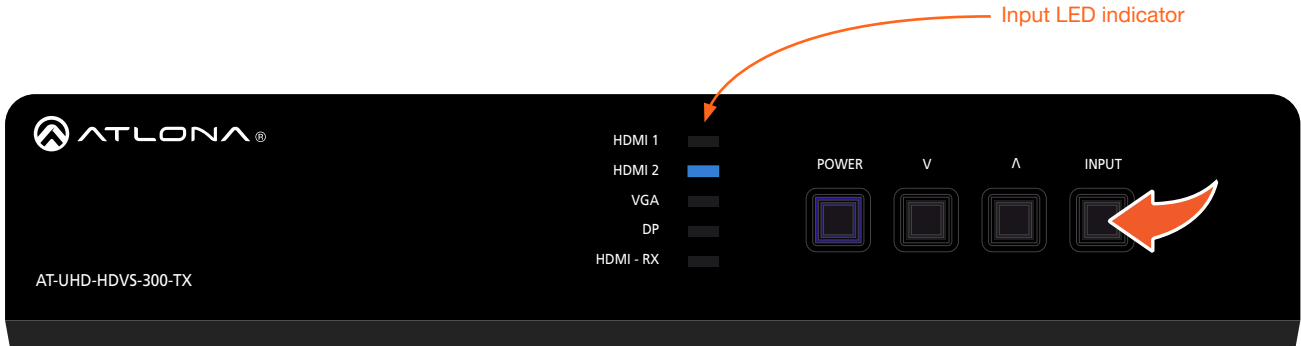
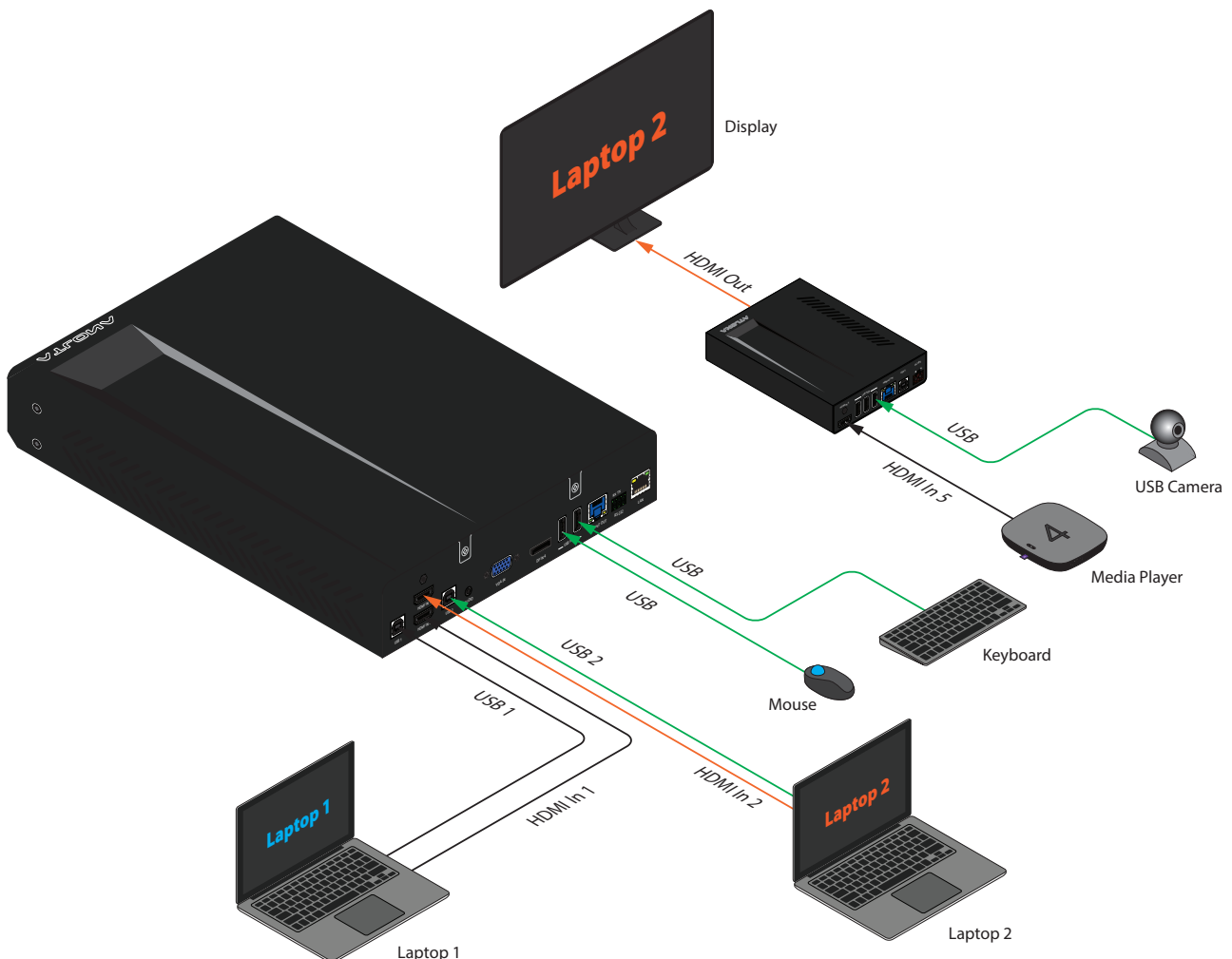

Figure 1.2 - HDMI 2 is selected as the active video input and Laptop 2 has access to the mouse, keyboard, and camera. For purposes of clarity, the HDBaseT connection between the transmitter and receiver is not shown. Black signal lines indicate that the AT-UHD-HDVS-300 is not switched to that input.



Follow USB

This mode is similar to auto-switching for video. The AT-UHD-HDVS-300-TX will detect which USB port is connected to the host device. If both USB host ports are connected to separate host device, then the AT-UHD-HDVS-300-TX will set the last-connected USB host device as the “active” USB host. Use the procedure below to enable Follow USB mode.

1. Launch a web browser and login to the web GUI. The factory-default username and password are listed below:

Username: root
Password: Atlona

2. Click **Setting** in the side menu bar.
3. Locate the **USB Host** section.
4. Click the **Follow USB** radio button.
5. Click the **Save** button to commit changes or click **Cancel** to abort the changes.

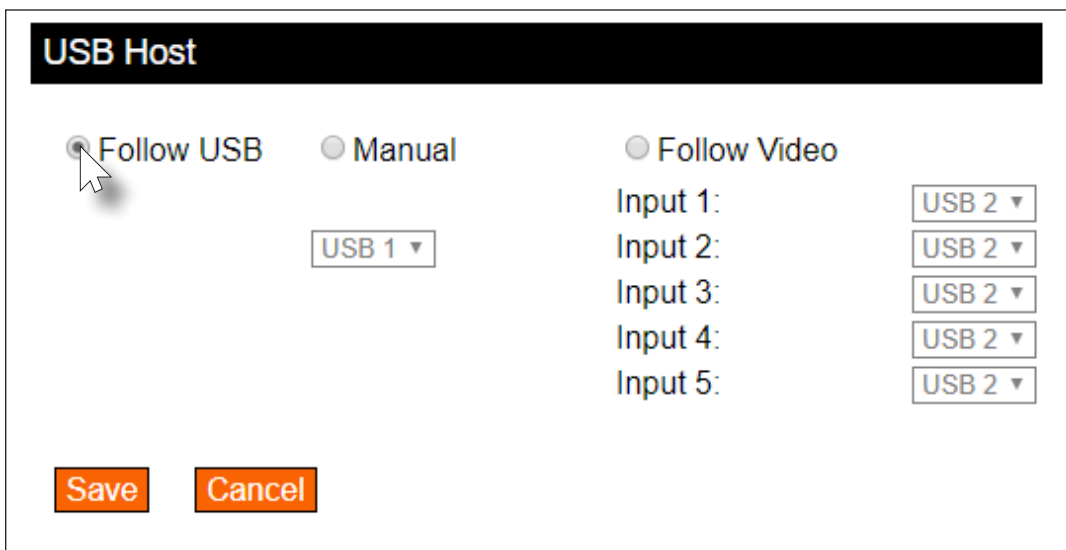

USB Host

Follow USB
 Manual
 Follow Video

Input 1: USB 2 ▼
 Input 2: USB 2 ▼
 Input 3: USB 2 ▼
 Input 4: USB 2 ▼
 Input 5: USB 2 ▼

Once set to **Follow USB** mode, the AT-UHD-HDVS-300-TX will exhibit the following behavior:

- If only one USB host port is connected, then the AT-UHD-HDVS-300-TX will use the USB host device connected to that port.
- If an another USB host device is connected to the unused USB host port, then the AT-UHD-HDVS-300-TX will automatically switch to that USB host device.
- If *both* **USB 1** and **USB 2** host ports are connected, then the AT-UHD-HDVS-300-TX will switch to the USB port that was connected last.
- If *both* **USB 1** and **USB 2** host ports are connected, and one USB host port is disconnected, then the AT-UHD-HDVS-300-TX will automatically switch to the other USB host port.

Manual

This mode provides manual selection of the USB host port to be used.

1. Launch a web browser and login to the web GUI. The factory-default username and password are listed below:

Username: root
Password: Atlona

2. Click **Setting** in the side menu bar.
3. Locate the **USB Host** section.
4. Click the **Manual** radio button.
5. Click the drop-down list to set the active USB host port.
6. Click the **Save** button to commit changes or click **Cancel** to abort the changes.

USB Host

Follow USB

Manual

Follow Video

USB 1 ▾

USB 1

USB 2

Input 1:

USB 2 ▾

Input 2:

USB 2 ▾

Input 3:

USB 2 ▾

Input 4:

USB 2 ▾

Input 5:

USB 2 ▾

Save

Cancel

7. Repeat Steps 2 through 6 to switch to the opposite USB host port.

AT-UHD-HDVS-300-KIT

22

RS-232 Control

The AT-UHD-HDVS-300-KIT provides an RS-232 port on both the transmitter and the receiver. There are two modes of RS-232 control: Pass-through and display control.

It should be noted that the AT-UHD-HDVS-300-KIT cannot be controlled using RS-232. Direct control of the AT-UHD-HDVS-300-KIT is only supported through the TCP/IP protocol.

Pass-through mode

In pass-through mode, an automation control system is used to control an RS-232 device. The most common configuration is connecting a control system to the **RS-232** port on the transmitter and the device to be controlled to the **RS-232** port on the receiver. However, RS-232 is bidirectional, which allows the control system to be connected to the receiver and the device to be controlled to the headend (where the sources are located).

Figure 1.3 - Pass-through mode. Controlling a display or other RS-232 device from the headend.

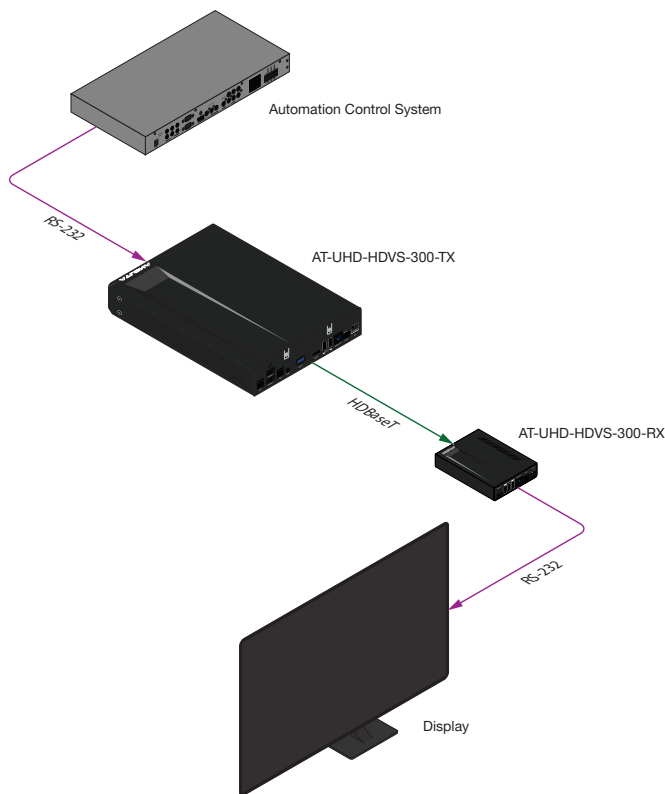
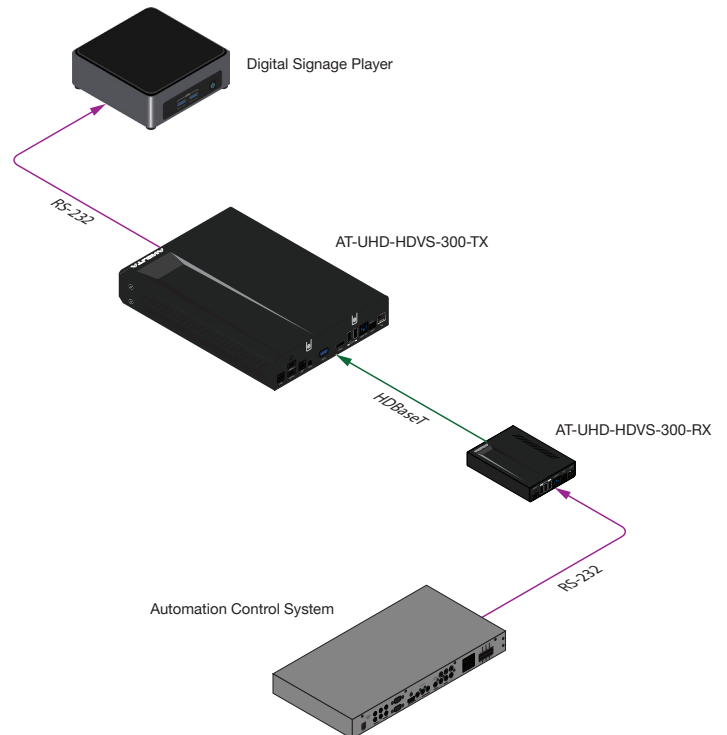

Figure 1.4 - Pass-through mode. Controlling a Digital Signage Player or other RS-232 device from the receiver endpoint.



1. Make the required connections, as illustrated in the examples on the previous page.
2. Launch a web browser and login to the web GUI. The factory-default username and password are listed below:

Username: root
Password: Atlona

3. Click **Control** in the side menu bar.
4. Click the **RS-232 Control** drop-down list and select **Pass-Thru**.

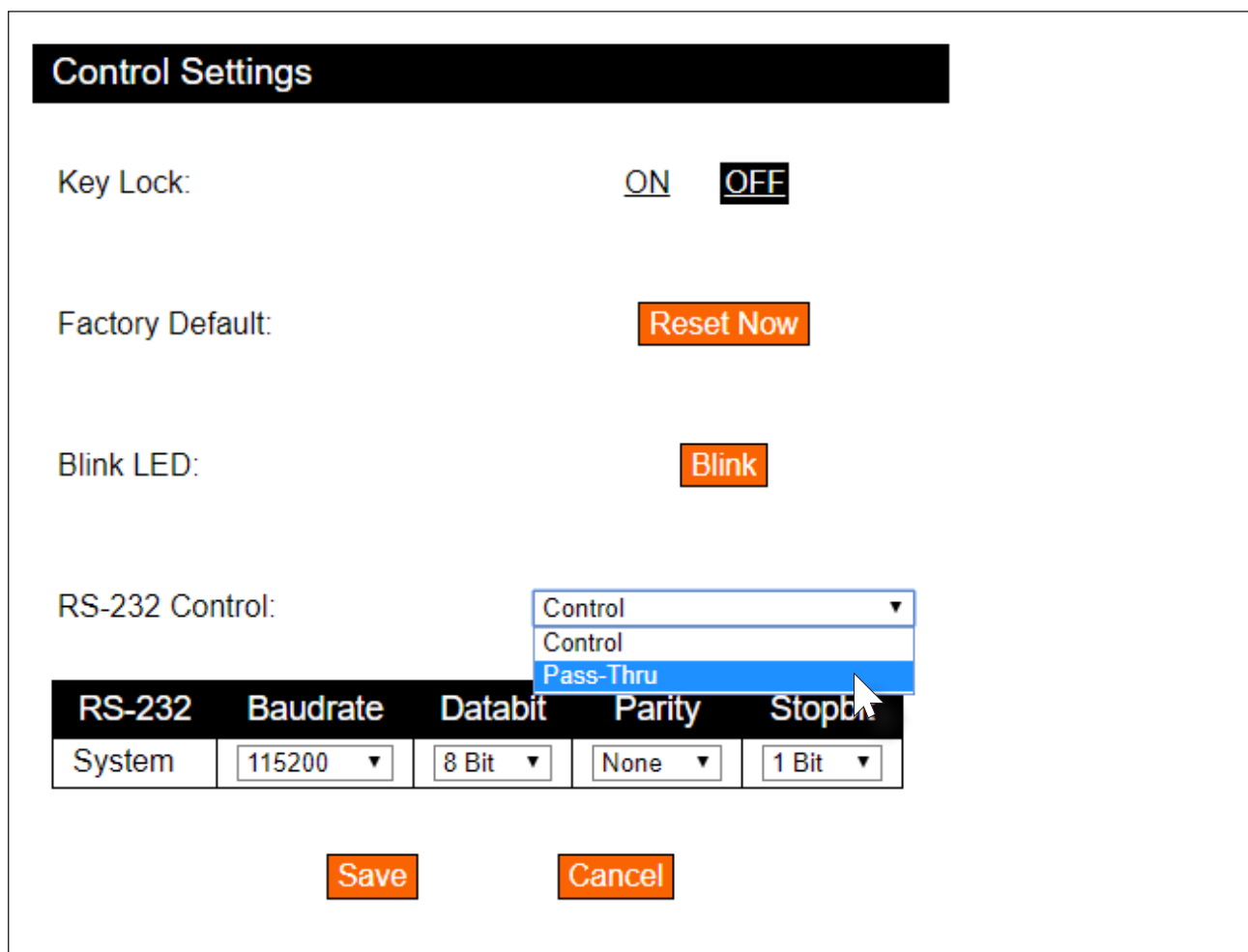

Control Settings

Key Lock: ON OFF

Factory Default:

Blink LED:

RS-232 Control:

RS-232	Baudrate	Databit	Parity	Stopbit
System	115200	8 Bit	None	1 Bit

5. Set the required baud rate, data bit, parity, and stop bit, which the control system will use for controlling the RS-232 device.
6. Click the **Save** button to commit changes or click **Cancel** to abort changes.

Control mode

In control mode, the RS-232 is used to control the device that is connected to the receiver. Control mode allows the sink device to be controlled using the front panel buttons on the AT-UHD-HDVS-300-TX.

The AT-UHD-HDVS-300-RX provides commands for the following operations:

- Power On
- Power Off
- Volume Up
- Volume Down
- Mute (volume)

Figure 1.5 - Control mode. Controlling a display or other RS-232 device from commands stored in the receiver.

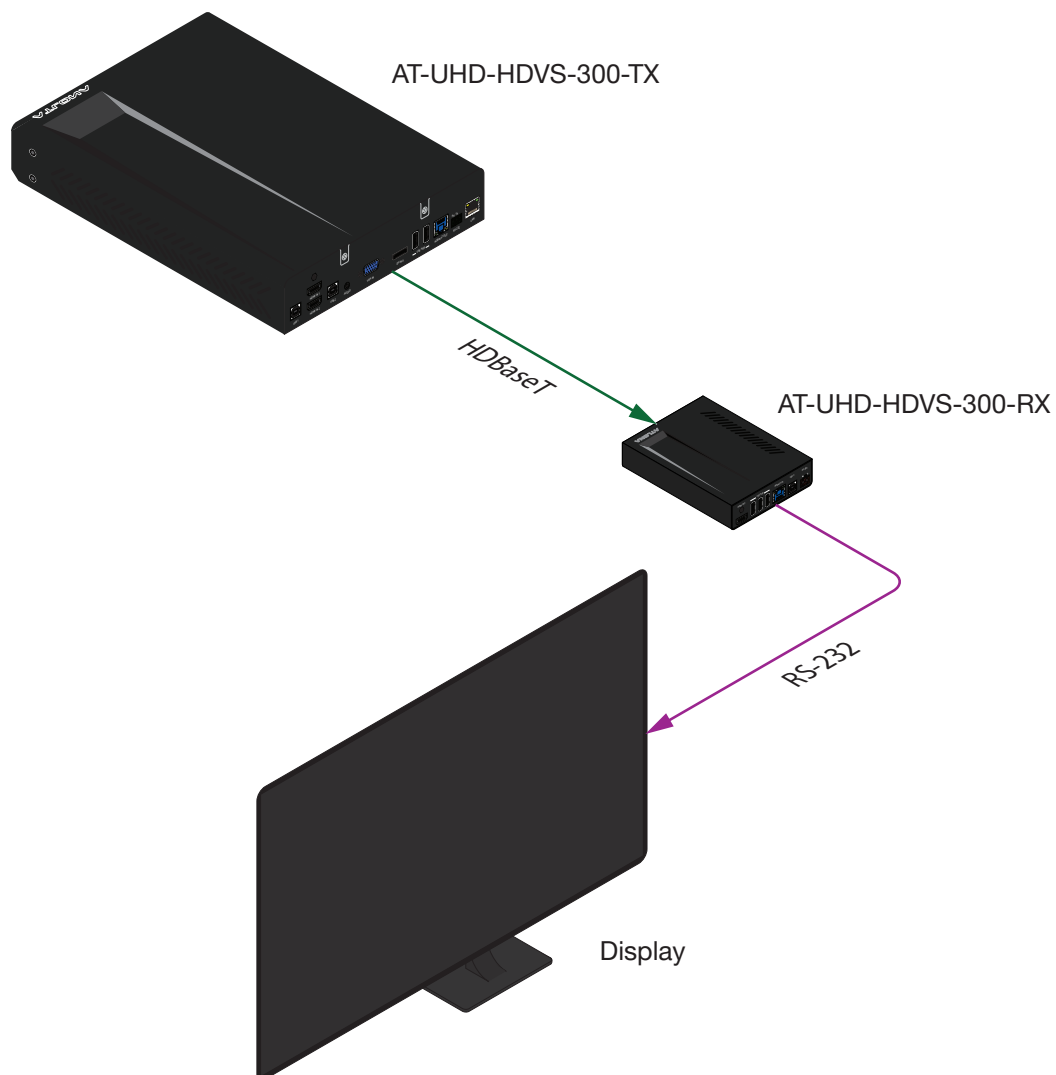

1. Make the required connections, as illustrated in the examples on the previous page.
2. Launch a web browser and login to the web GUI. The factory-default username and password are listed below:

Username: root
 Password: Atlona

3. Click **Control** in the side menu bar.
4. Click the **RS-232 Control** drop-down list and select **Control**.

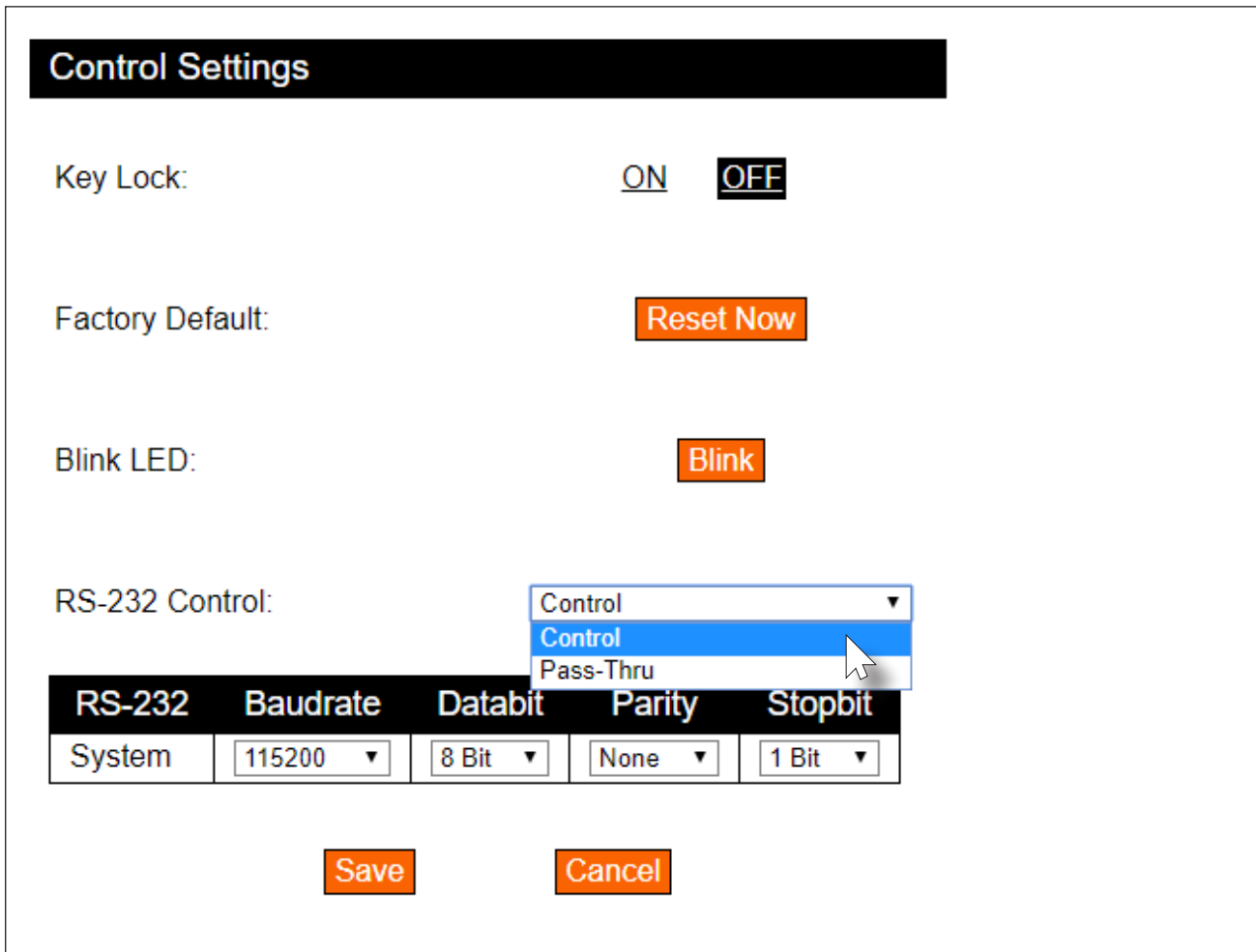

5. Set the required baud rate, data bit, parity, and stop bit settings for the RS-232 device. Consult the User Manual for the RS-232 device, if necessary.
6. Click the **Save** button to commit changes or click **Cancel** to abort changes.
7. Click **Command** in the side menu bar.

8. Click the **ASCII** or **HEX** radio button to select the desired command format. This option can be changed at any time.
9. Click the **Feedback Verify** drop-down list to enable or disable command feedback.
10. Click the **Delay (Sec)** drop-down list to select the delay between each command, if multiple commands are required or used. Multiple command must be separated by a comma.

RS-232/IP Commands
Reset

ASCII HEX

Delay between commands separated ,

Feedback Verify Off ▼

Delay (Sec) 5 ▼

Test On

Feedback

None ▼

Test Off

Feedback

None ▼

Test Volume+

11. Enter the command(s), required by the sink device, in each field. Refer to the User Manual of the sink device for a list of the required commands. In the example, below, the required command for powering-off the RS-232 device has been entered.

Feedback

None ▼

Test Off

PWOFF

Feedback

None ▼

AT-UHD-HDVS-300-KIT

27

12. Click **Test** button to test the command. If the command is processed successfully, then the “Processed!” message will appear, as shown, below.

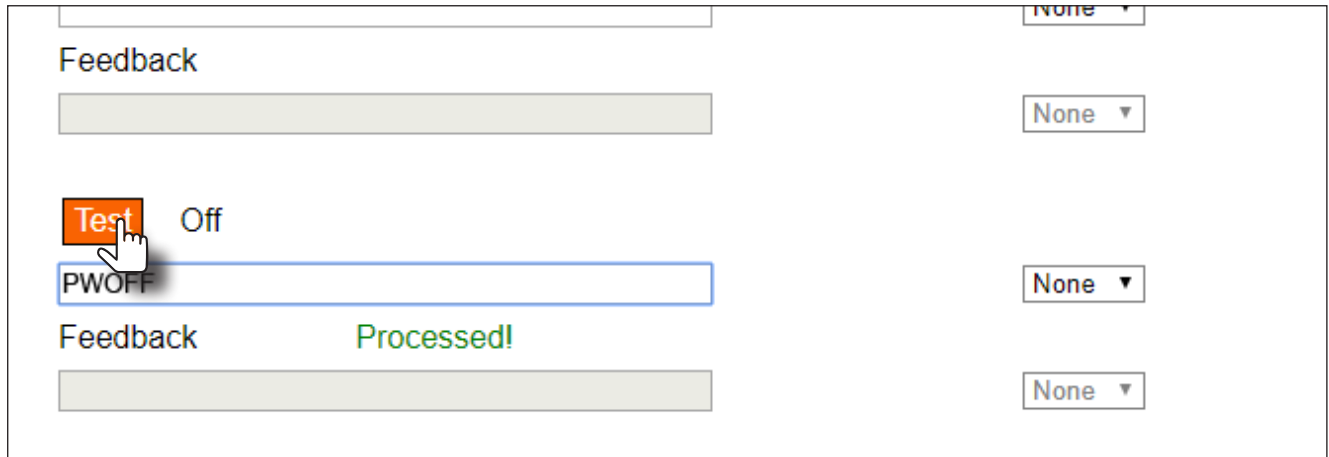

13. Press the **POWER** button on the front panel to power-on the AT-UHD-HDVS-300-TX. The display will need to be powered-on, separately, since a power-on command has not yet been defined. The power-on command, along with any other commands, can be added at this time.

14. Press the **POWER** button on the front panel. Both the AT-UHD-HDVS-300-TX and the sink will be powered-off.

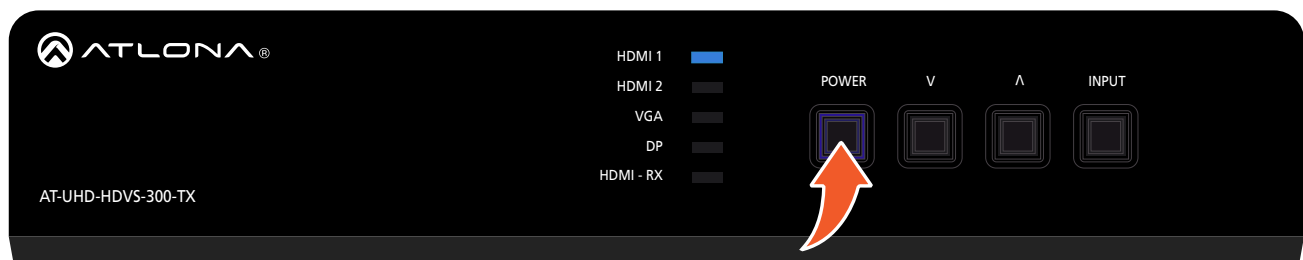

NOTE: Powering-off the AT-UHD-HDVS-300-KIT places both the transmitter and receiver in a very low power state (< 500 mA). Access to the web GUI will still be available after a power-off command has been processed.

The Web GUI

Introduction to the Web GUI

The AT-UHD-HDVS-300-TX includes a built-in web GUI. Atlona recommends that the web GUI be used to set up the AT-UHD-HDVS-300-TX, as it provides intuitive management of all features.

The AT-UHD-HDVS-300-TX is shipped with DHCP enabled. Once connected to a network, the DHCP server will automatically assign an IP address to the unit. Use an IP scanner to determine the IP address of the AT-UHD-HDVS-300-TX. If a static IP address is desired, refer to [IP Configuration \(page 14\)](#). The default static IP address of the AT-UHD-HDVS-300-TX is 192.168.1.254.

1. Launch a web browser.
2. In the address bar, type the IP address of the AT-UHD-HDVS-300-TX.
3. The **Login** page will be displayed.



4. Type root, using lower-case characters, in the **Username** field.
5. Type Atlona in the **Password** field. This is the default password. The password field is case-sensitive. When the password is entered, it will be masked. The password can be changed, if desired. Refer to [Users page \(page 35\)](#) for more information.
6. Click the **Login** button or press the ENTER key on the keyboard.



7. The **Status** page will be displayed.

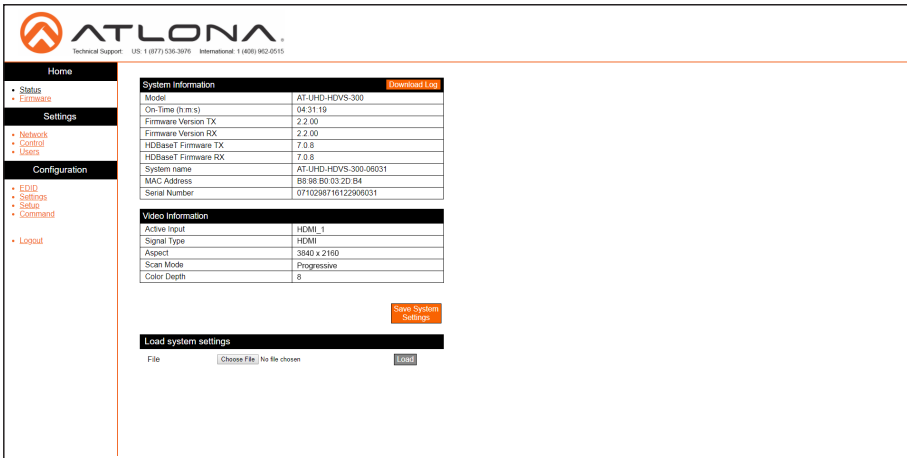

8. Click **Logout** on the side menu bar, to log out and return to the login screen.

Menu Bar

The window on the left side of the screen is the menu bar. The menu system is divided into three sections: **Home**, **Settings**, and **Configuration**. When the mouse is moved over each menu item, it will be highlighted in black. Click the menu item to go that page.

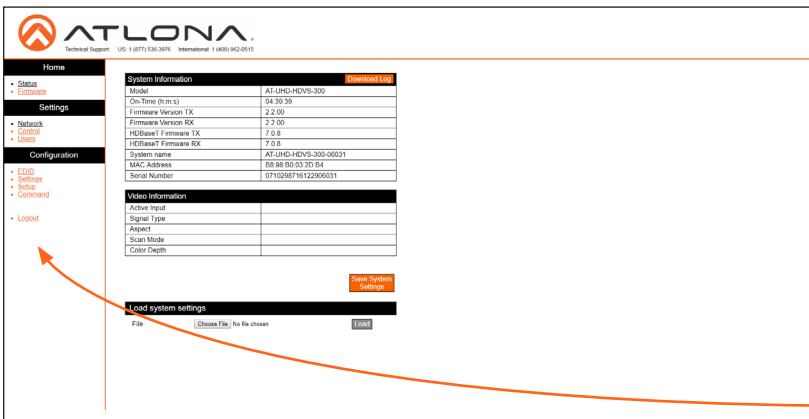

Menu bar

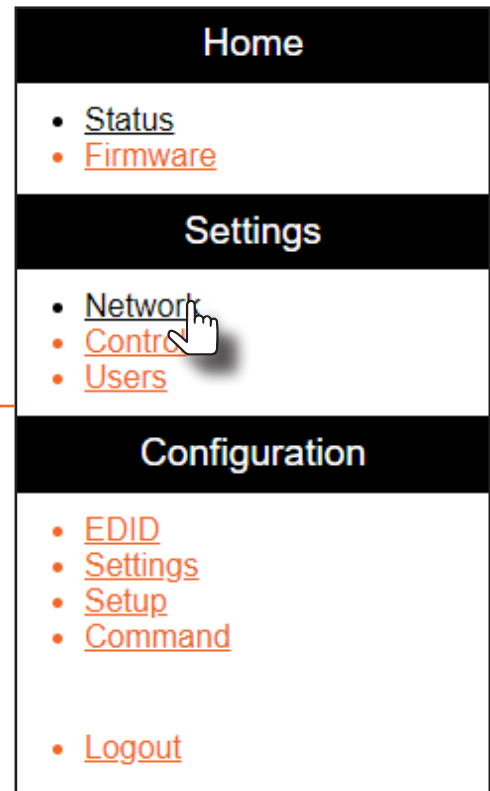

Status page

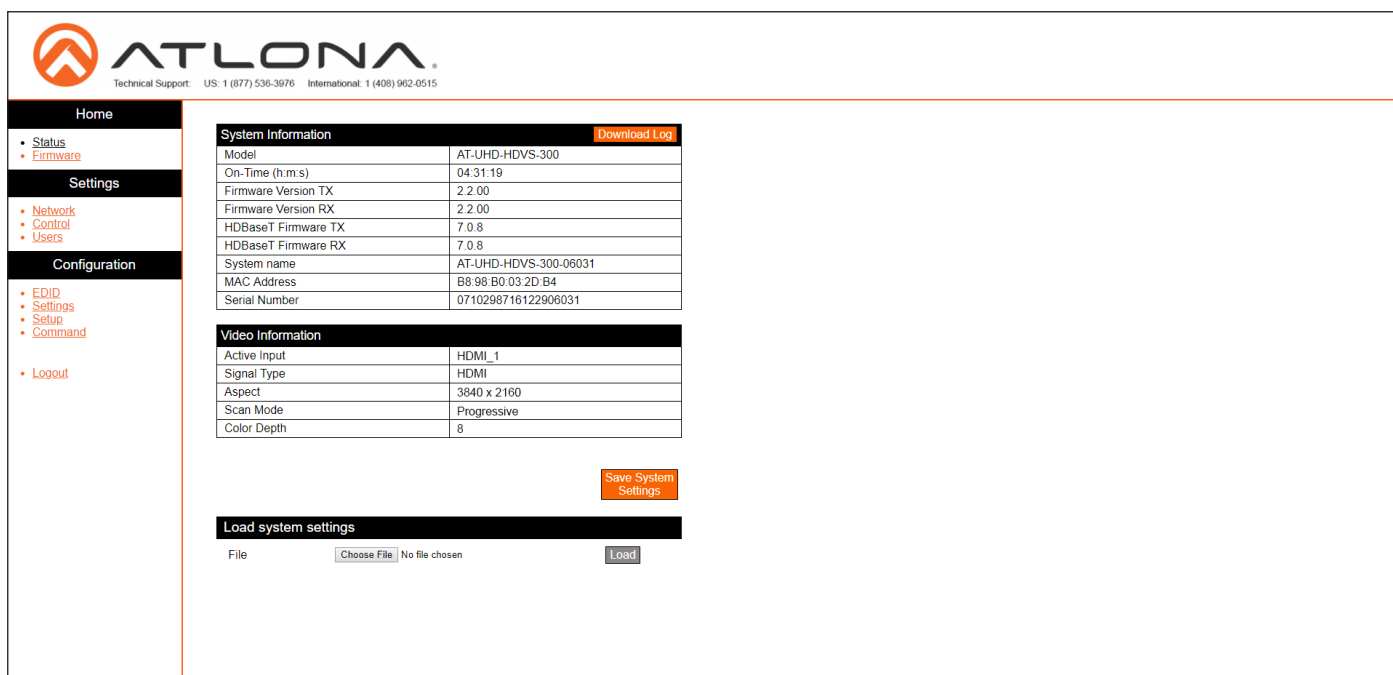

The screenshot shows the ATLONA web GUI interface. At the top left is the ATLONA logo and technical support information. A navigation sidebar on the left includes Home, Status, Firmware, Settings, Configuration, and Logout. The main content area is titled 'System Information' and contains two tables: 'System Information' and 'Video Information'. Below the tables are buttons for 'Download Log', 'Save System Settings', and a file upload section for 'Load system settings'.

System Information	
Model	AT-UHD-HDVS-300
On-Time (h:m:s)	04:31:19
Firmware Version TX	2.2.00
Firmware Version RX	2.2.00
HDBaseT Firmware TX	7.0.8
HDBaseT Firmware RX	7.0.8
System name	AT-UHD-HDVS-300-06031
MAC Address	B8 98 B0 03 2D B4
Serial Number	0710298716122906031

Video Information	
Active Input	HDMI_1
Signal Type	HDMI
Aspect	3840 x 2160
Scan Mode	Progressive
Color Depth	8

Model Name

The model SKU of this product.

On-Time (h:m:s)

The time in which the unit has been in the “on” state since it was last rebooted.

Firmware Version TX

The current firmware version of the transmitter.

Firmware Version RX

The current firmware version of the receiver.

HBaseT Firmware TX

The current HDBaseT firmware version of the transmitter.

HBaseT Firmware RX

The current HDBaseT firmware version of the receiver.

System name

This field represents the name of the system and is created by combining the product name (SKU) with the last five digits of the serial number of the unit. This name can be changed by editing the **Hostname** field on the [Network page \(page 33\)](#) page.

MAC Address

The MAC address of the AT-UHD-HDVS-300-TX.

Serial Number

The serial number of the unit.

Active Input

Displays the active input.

Signal Type

Displays the resolution of the video input signal.

Aspect

Displays the aspect ratio of the video input signal.

Scan Mode

Displays the scan mode: Progressive or Interlaced.

Color Depth

Displays the color depth of the video input signal.

Choose file

Click this button to select the desired system settings file. Click the Load button to upload the settings file to the AT-UHD-HDVS-300-TX.

Save System Settings

Click this button to save the system settings to a local file. System settings files are saved in .JSON format. The default system settings filename is download.json. It is recommended to save the system settings before performing a firmware update.

Firmware page

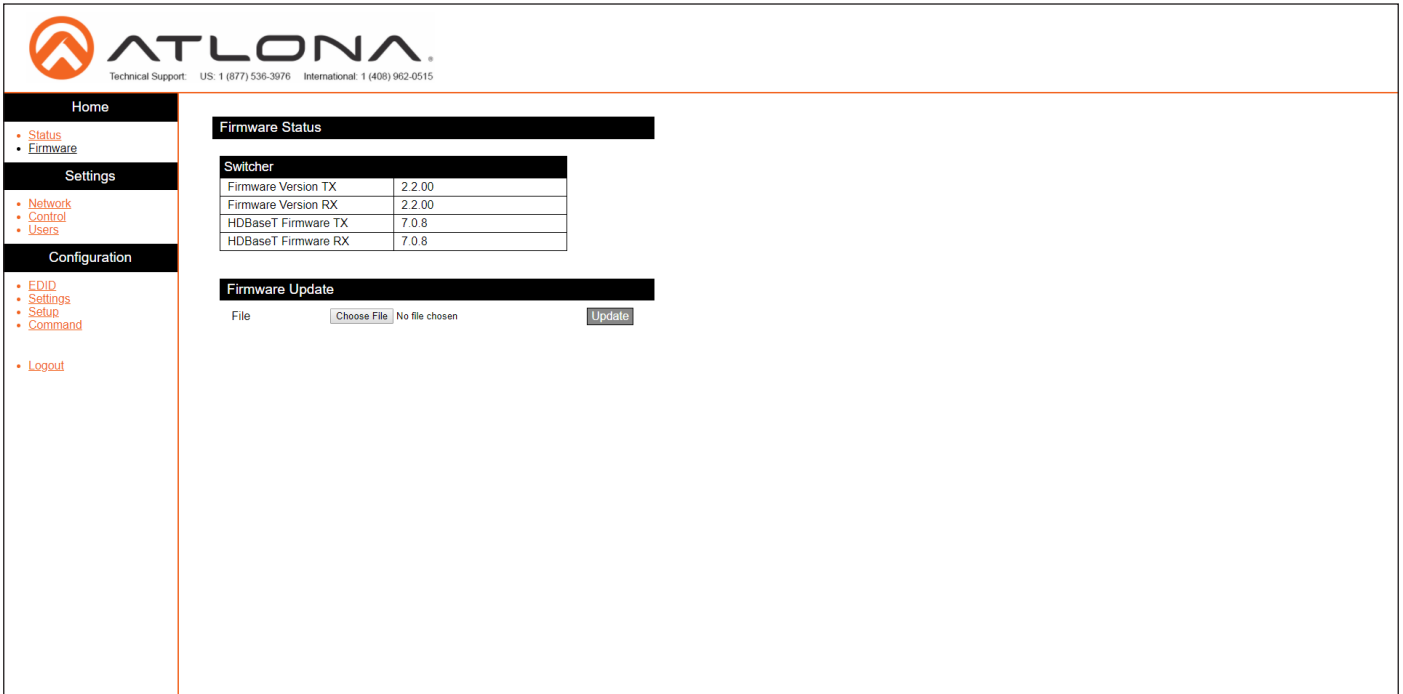

The screenshot shows the ATLONA web GUI interface. At the top left is the ATLONA logo with technical support information: US: 1 (877) 536-3976, International: 1 (408) 962-0515. A navigation menu on the left includes Home, Status, Firmware, Settings (Network, Control, Users), Configuration (EDID, Settings, Setup, Command), and Logout. The main content area is titled 'Firmware Status' and contains a table for 'Switcher' with the following data:

Switcher	
Firmware Version TX	2.2.00
Firmware Version RX	2.2.00
HDBaseT Firmware TX	7.0.8
HDBaseT Firmware RX	7.0.8

Below the table is a 'Firmware Update' section with a file upload area. It shows a 'File' label, a 'Choose File' button, the text 'No file chosen', and an 'Update' button.

Firmware Version TX

The current firmware version of the transmitter.

Firmware Version RX

The current firmware version of the receiver.

HBaseT Firmware TX

The current HDBaseT firmware version of the transmitter.

HBaseT Firmware RX

The current HDBaseT firmware version of the receiver.

Choose file

Click this button to select the firmware file. Click the **Upload** button to begin the update procedure. Refer to [Updating the Firmware \(page 43\)](#) for more information.

Network page

After pressing the **Save** button, a reboot message will appear at the top of the web GUI. The AT-UHD-HDVS-300-TX must be rebooted when any network setting is changed.

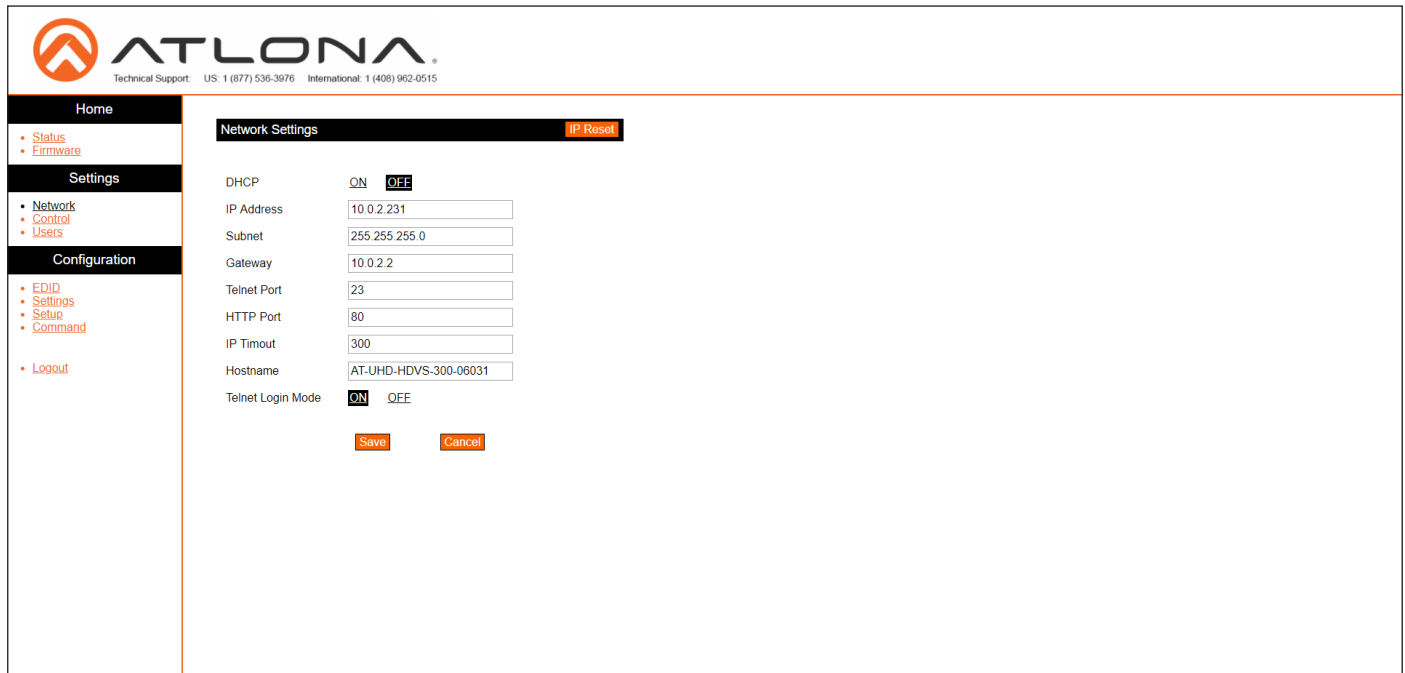

DHCP

Click the **ON** button to enable DHCP. Click the **OFF** button to enable static IP mode. In static IP mode, the IP Address, Subnet, and Gateway fields can be modified.

IP Address

Enter the IP address of the AT-UHD-HDVS-300-TX in this field. This field can only be changed when DHCP is set to **OFF**.

Subnet

Enter the subnet mask in this field. This field can only be changed when DHCP is set to **OFF**.

Gateway

Enter the gateway (router) IP address in this field. This field can only be changed when DHCP is set to **OFF**.

Telnet Port

Enter the Telnet listening port in this field. The default port is 23.

HTTP

Enter the HTTP listening port in this field. The default port is 80.

IP Timeout

Enter the time-out interval, in seconds, in this field. This field represents the time interval before the TCP/IP connection times out.

Hostname

Enter the desired hostname in this field. By default, the hostname is the product (SKU) plus the last five digits of the unit serial number.

Telnet Login Mode

Click the **ON** button to prompt for username and password credentials. Username and password credentials are the same as the web GUI login credentials. Click the **OFF** button to prevent Telnet sessions from being opened.

Save / Cancel

Click the **Save** button after any changes have been made. Click the **Cancel** to abort changes.

Control page

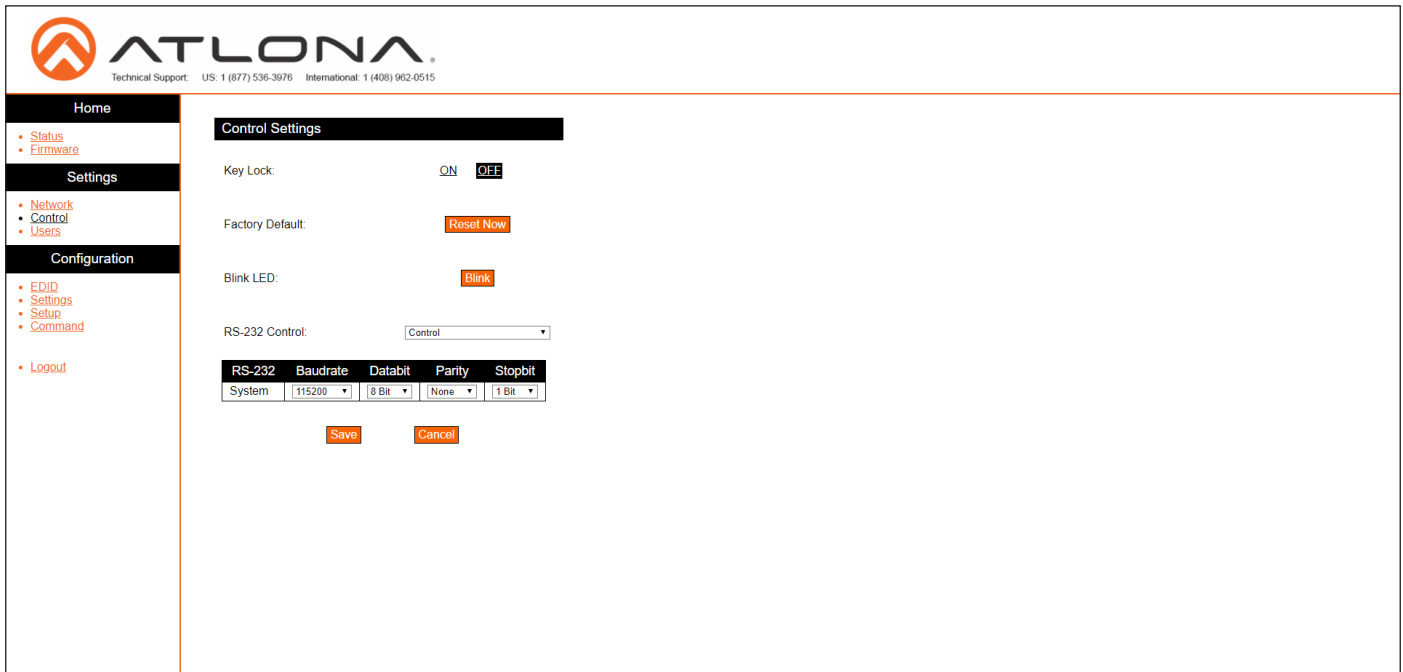

Key Lock

Click the **ON** button to lock all button on the front panel. Click the **OFF** button to unlock the buttons on the front panel.

Factory Default

Click the **Reset Now** button to reset the AT-UHD-HDVS-300-KIT to factory-default settings.

Blink LED

Click the **Blink** button to start the POWER LED blinking. This feature is useful to identify the unit on a network, if multiple units are being used.

RS-232 Control

Click this drop-down list to select the desired RS-232 control method. The AT-UHD-HDVS-300-KIT supports either **Control** or **Pass-Thru** mode. Refer to [RS-232 Control \(page 23\)](#) for more information.

Setting	Description
Baud rate	Sets the baud rate. The following options are available: 9600, 19200, 38400, 56000, 57600, 115200.
Data bit	Sets the number of data bits used to represent each character of data. The following options are available: 8 or 9.
Parity	Sets the parity bit, which can be included with each character to detect errors during the transmission of data. The following options are available: None, Odd, or Even.
Stop bit	Sets the stop bit. Stop bits are sent at the end of each character, allowing the client to detect the end of a character stream. The following options are available: 1 or 2.

Save / Cancel

Click the **Save** button to apply all changes. Click the **Cancel** button to abort changes.

Users page

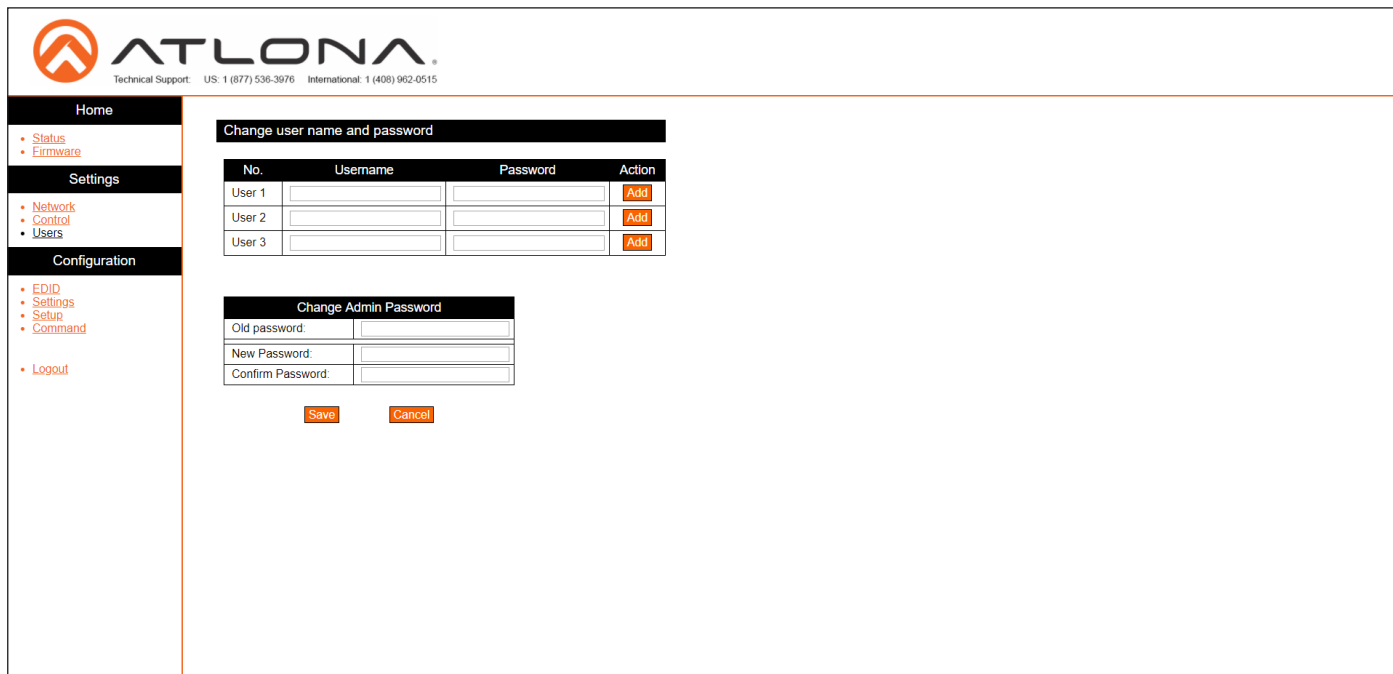



ATLONA

Technical Support: US: 1 (877) 536-3976 International: 1 (408) 962-0515

Home

- Status
- Firmware

Settings

- Network
- Control
- Users

Configuration

- EDID
- Settings
- Setup
- Command

• Logout

Change user name and password

No.	Username	Password	Action
User 1	<input type="text"/>	<input type="password"/>	<input type="button" value="Add"/>
User 2	<input type="text"/>	<input type="password"/>	<input type="button" value="Add"/>
User 3	<input type="text"/>	<input type="password"/>	<input type="button" value="Add"/>

Change Admin Password

Old password:	<input type="password"/>
New Password:	<input type="password"/>
Confirm Password:	<input type="password"/>

No.

The column used to identify each user.

Username

Enter the username in this field. Special characters (e.g. #, %, @, &, etc.) are not permitted.

Password

Enter the password for the user in this field. Special characters (e.g. #, %, @, &, etc.) are not permitted.

Action

Click the **Add** button to create the user, once the information in the username and password fields have been entered.

Change Admin Password

- **Old password**
Enter the current password in this field. The default password is Atlona.
- **New Password**
Enter the new password in this field.
- **Confirm Password**
Verify the new password by entering it in this field.

Save / Cancel

Click the Save button to apply all changes. Click the **Cancel** button to abort changes.

AT-UHD-HDVS-300-KIT

35

EDID page

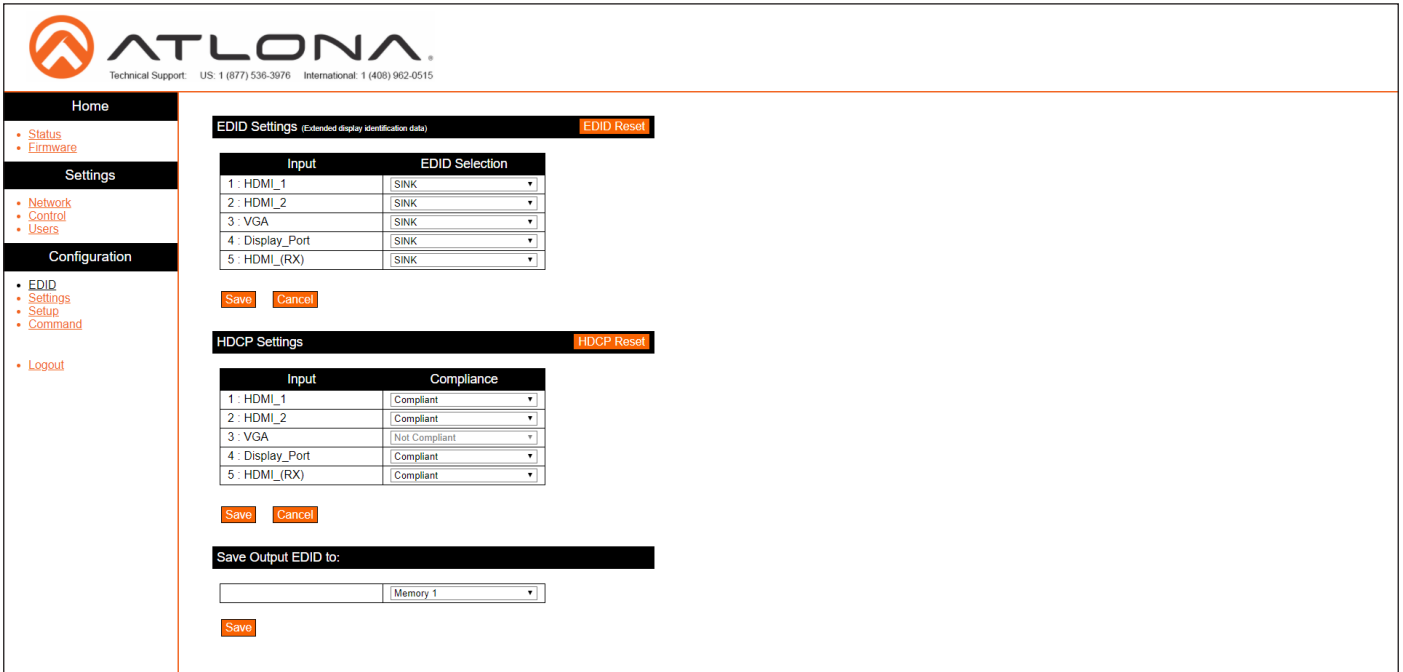

Input / EDID Selection

The **Input** column lists all available inputs, including **HDMI IN 5** located on the AT-UHD-HDVS-300-RX. Click the drop-down list for the desired input, under the **EDID Selection** column, to select the EDID. Note that the EDID selections will be dependent on the input type. The available EDID selections are listed in the table below.

Memory 1 through Memory 4 are used for storing EDID data

Click the **Save** button to confirm the EDID selection. Click the **Cancel** button to abort the changes.

EDID Selections	
SINK (uses downstream / display EDID)	1280x800 RGB 2CH
4K 60 MC	1280x800 DVI
4K 60 2CH	1366x768 RGB 2CH
4K 30 MC	1024x768 RGB 2CH
4K 30 2CH	720P DD
1920x1200 RGB 2CH	720P 2CH
1080P DD	800x600 RGB 2CH
1080P MC	Memory 1
1080P 2CH	Memory 2
1080P 3D DD	Memory 3
1080P 3D 2CH	Memory 4
1080P DVI	

Input / Compliance

The **Input** column lists all available inputs, including **HDMI IN 5** on the receiver. Click the drop-down list for the desired input, under the **Compliance** column, to select the HDCP setting. Note that the HDCP compliance cannot be set for the VGA input, as this interface cannot accept HDCP content.

- **Compliant** - Reports to the source device that the display (sink) is an HDCP-compliant device. The source will send HDCP content to the display (sink) device.
- **Not Compliant** - Reports to the source device that the display (sink) is a non-HDCP-compliant device. The source will not send HDCP content.
- **Auto** - Automatically detects the presence of HDCP-compliant sink devices. If an HDCP-compliant display is detected, then HDCP content will be sent. Otherwise, no HDCP content is sent.

Click the **Save** button to confirm the EDID selection. Click the **Cancel** button to abort the changes.



NOTE: The HDCP control feature does **not** provide decryption of HDCP content to non-compliant sink devices.

Save Output EDID to

Saves the EDID of the display, connected to **HDMI Out** port on the receiver, to the specified memory location. Click the drop-down list to select the desired memory location (Memory 1 - Memory 4). Click the **Save** button to confirm the operation.

Settings page

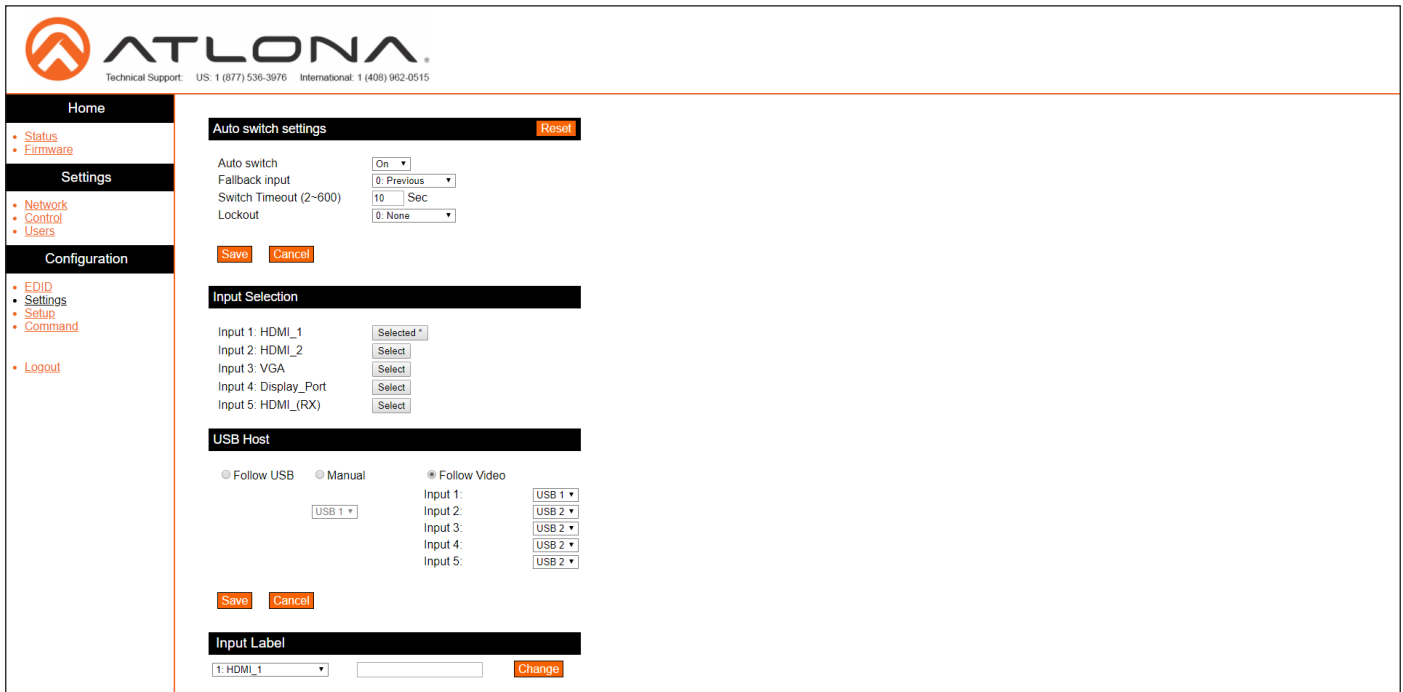

Auto switch

Click this drop-down list to enable or disable video auto-switching. When set to **On**, and a new source is connected, the AT-UHD-HDVS-300-KIT will automatically switch to that input (including **HDMI IN 5** on the receiver). Click the **Reset** button to set auto-switch settings to factory-default settings. Click the **Save** button to commit changes or click the **Cancel** button to abort changes.

Fallback input

Click this drop-down list to select the fallback input. The fallback input is the input designated to switch to when a source change has occurred. Click the **Save** button to commit changes or click the **Cancel** button to abort changes.

Switch Timeout (2 - 600)

Enter the auto-switch timeout, in seconds. This value defines the time interval that must expire before the AT-UHD-HDVS-300-KIT switches to another input (including **HDMI IN 5** on the receiver). Click the **Save** button to commit changes or click the **Cancel** button to abort changes.

Lockout

Click this drop-down list to select the desired lockout setting. Click the **Save** button to commit changes or click the **Cancel** button to abort changes.

Input Selection

Click the button, next to the input name, to switch to that input.

USB Host

Defines the behavior of the USB host ports for switching operations. Refer to [USB Modes \(page 17\)](#) for more information. Click the **Save** button to commit changes or click the **Cancel** button to abort changes.

Input Label

Click the drop-down list to select the input to be renamed. Enter the new name of the input in the text box across from the drop-down list. Click the **Change** button to commit changes.

Setup page

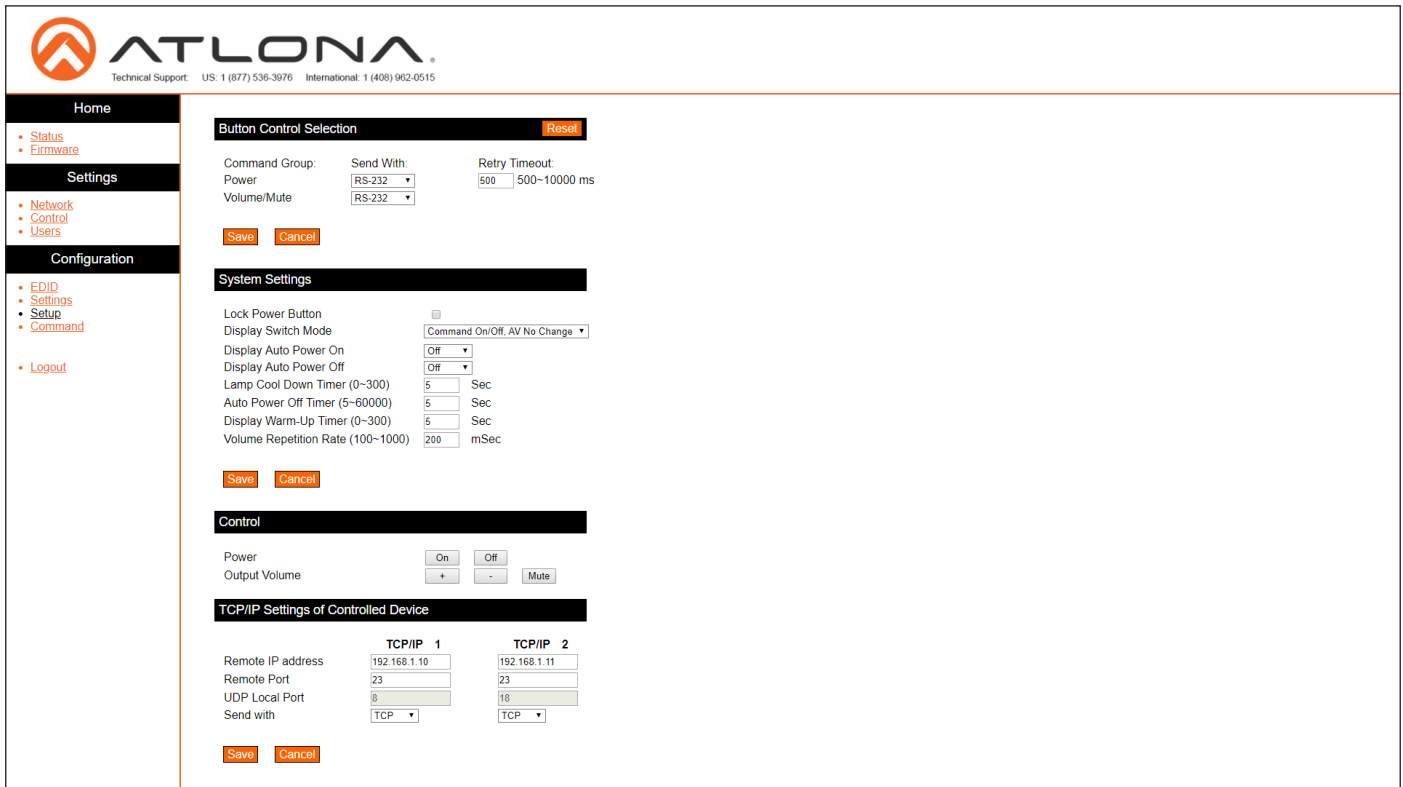

Button Control Selection Reset

Command Group: Send With: Retry Timeout:
 Power: RS-232 500 500-10000 ms
 Volume/Mute: RS-232

Save Cancel

System Settings

Lock Power Button
 Display Switch Mode: Command On/Off, AV No Change
 Display Auto Power On: Off
 Display Auto Power Off: Off
 Lamp Cool Down Timer (0-300): 5 Sec
 Auto Power Off Timer (5-60000): 5 Sec
 Display Warm-Up Timer (0-300): 5 Sec
 Volume Repetition Rate (100-1000): 200 mSec

Save Cancel

Control

Power: On Off
 Output Volume: + - Mute

TCP/IP Settings of Controlled Device

	TCP/IP 1	TCP/IP 2
Remote IP address	192.168.1.10	192.168.1.11
Remote Port	23	23
UDP Local Port	0	10
Send with	TCP	TCP

Save Cancel

Power

Click this drop-down list and select the protocol used to send the power command.

Volume/Mute

Click this drop-down list and select the protocol used to send volume and mute commands.

Retry Timeout

Enter the time interval before the command is resent, if a failure should occur.

Lock Power Button

Allows the **POWER** button on the front panel to be locked, preventing accidental operation when the product is in use. Click this check box to enable this feature.

Display Switch Mode

Click this drop-down list to set the display switching mode.

Note that Display Switch Mode can only be configured if **RS-232 Control** is set to **Control**. Refer to the [Control page \(page 34\)](#) for more information. If **RS-232 Control** is set to **Pass-Thru**, when assigning the Display Switch Mode, then an error message will be displayed.

Setting	Description
Command None, AV On/Off	Display is always ON, but the source can be powered-on or powered-off.
Command On/Off, AV On/Off	Both the source and display can be powered-on or powered-off.
Command On/Off, AV No Change	Display can be powered-on or powered-off, but the source is always on.

Display Auto Power On

Sends the command to power-on the display when an A/V signal is detected. Click the drop-down list and select **On** to enable this feature.

Display Auto Power Off

Sends the command to power-off the display after the **Auto Power Off Timer** has expired. Click the drop-down list and select **On** to enable this feature.

Lamp Cool Down Timer

Sets the cool-down interval, in seconds, before the projector can be powered-off. During this time interval, the projector will not accept any commands until the “power off” command has been processed and the projector lamp has completed the cool-down cycle. Range: 0 to 300.

Display Auto Power On

Sends the command to power-on the display when an A/V signal is detected. Click the drop-down list and select **On** to enable this feature.

Display Auto Power Off

Sends the command to power-off the display after the **Auto Power Off Timer** has expired. Click the drop-down list and select **On** to enable this feature.

Lamp Cool Down Timer

Sets the cool-down interval, in seconds, before the projector can be powered-off. During this time interval, the projector will not accept any commands until the “power off” command has been processed and the projector lamp has completed the cool-down cycle. Range: 0 to 300.

Auto Power Off Timer

Sets the time interval, in seconds, between when the loss of A/V signal is detected and when the “Display Off” command is sent. Range: 5 seconds to 1 hour.

Display Warm Up Timer

Sets the time interval, in seconds, between when the display is powered on and when the **POWER** button on the front panel will be locked. Range: 0 to 300.

Volume Repetition Rate

Enter this volume repetition rate in this field. This field defines how fast the volume is changed, when holding down the volume buttons on the front panel. Higher values will slow the rate at which the volume is changed.

Power

Click this **On** button to power-on the unit. Click the **Off** button to power-off the unit.

Output Volume

Click the + and - buttons to increase or decrease the volume, respectively. Click the **Mute** button to mute the audio output.

The AT-UHD-HDVS-300-KIT can control two separate IP devices on a network. However, only one device can be controlled at a time. Specify the IP settings in this section.

Remote IP address

Enter the remote IP address in this field.

Remote Port

Enter the remote listening port in this field.

UDP Local Port

Enter the local UDP listening port in this field.

Send with

Click this drop-down list to select either the TCP or UDP protocol, when sending commands.

Command page

The settings on this page only apply when the AT-UHD-HDVS-300-KIT is set to *control mode*. Refer to [Control mode \(page 25\)](#) for more information.

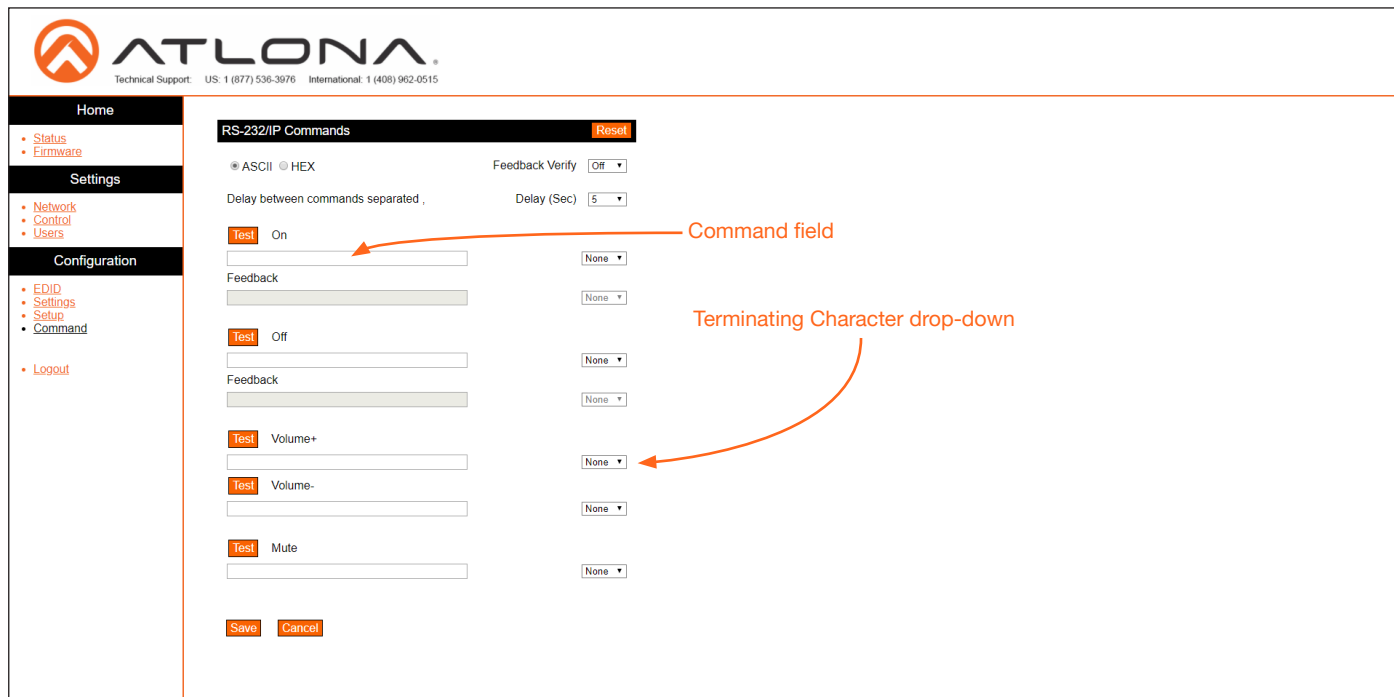

The screenshot shows the 'RS-232/IP Commands' configuration page. It includes a sidebar with navigation options like Home, Settings, and Configuration. The main content area has a 'Reset' button and radio buttons for 'ASCII' (selected) and 'HEX'. There is a 'Feedback Verify' dropdown set to 'Off' and a 'Delay (Sec)' dropdown set to '5'. Below these are several command entries, each with a 'Test' button, a text input field, and a 'None' dropdown menu. Annotations with arrows point to one of the text input fields labeled 'Command field' and one of the dropdown menus labeled 'Terminating Character drop-down'.

ASCII

Click this radio button to view all command fields in ASCII format.

HEX

Click this radio button to view all command fields in hexadecimal format.

Feedback Verify

Sets the feedback verification state. Click the toggle to enable or disable this feature. The following options are available.

Setting	Description
On	This is the default setting. If the feedback string is not acknowledged, then the AT-UHD-HDVS-300-RX will make four attempts to resend the command. After the fourth attempt, the process will fail.
Off	Sends the command and ignores the feedback string.

Delay (Sec)

Click this drop-down list to set the time interval between commands, when multiple commands are specified on the command line. Multiple commands must be separated by the comma delimiter.

Test

Click this button to test each command, once it is entered in the text box.

Terminating Character

Click these drop-down lists to select the terminating character, when sending the command.

Setting	Description
None	No end-of-line characters included
CR	Carriage return
LF	Line feed
CR-LF	Carriage return + Line feed
Space	Space character
Null	Null character (binary zero)

Appendix

Updating the Firmware

The AT-UHD-HDVS-300-KIT can only be updated through the webGUI.

Required items:

- New firmware - Downloaded from atlon.com
- IP address of the AT-UHD-HDVS-300-KIT
- Computer on the same network as the AT-UHD-HDVS-300-KIT
- Username and password to access the webGUI



IMPORTANT: Do not change the firmware file name, doing so may result in damage to the unit. In addition, Mozilla Firefox or Internet Explorer must be used when upgrading the firmware, due to incompatibilities with other web browsers.

1. Verify that an Ethernet cable is connected between the AT-UHD-HDVS-300-KIT and the network. The computer used to access the web GUI must be on the same network as the AT-UHD-HDVS-300-KIT.
2. Type the IP address of the AT-UHD-HDVS-300-KIT into a web browser, as shown in the example below.



IMPORTANT: If any stability issues are experienced, disable any anti-virus or firewall that may be interfering with network communication to the AT-UHD-HDVS-300-KIT. Once set up is done and the webGUI is no longer being used, the firewall and anti-virus can be re-enabled. For assistance, refer to the Support section on www.atlon.com and search for article KB01141.



3. The login screen will be displayed. Login using the username and password. The default login credentials are:

Username: root

Password: Atlon



IMPORTANT: Before updating the firmware, perform steps 4 - 6 to save the system settings to a file.

4. Click **Status** on the left side of the screen.

- Click the **Save System Settings** button.

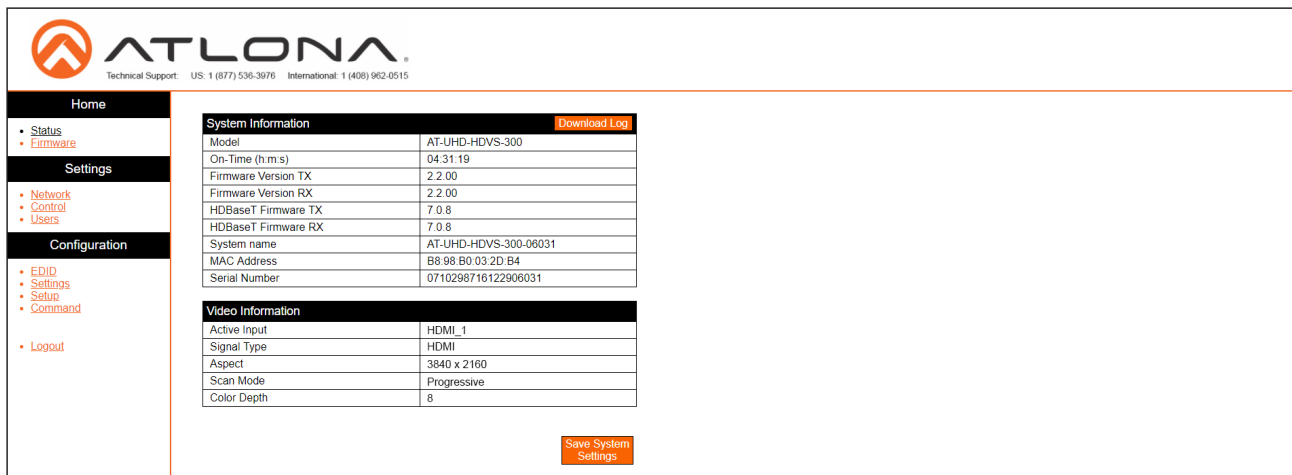

System Information [Download Log](#)

Model	AT-UHD-HDVS-300
On-Time (h.m.s)	04.31.19
Firmware Version TX	2.2.00
Firmware Version RX	2.2.00
HDBaseT Firmware TX	7.0.8
HDBaseT Firmware RX	7.0.8
System name	AT-UHD-HDVS-300-06031
MAC Address	B8.98.B0.03.2D.B4
Serial Number	0710298716122906031

Video Information

Active Input	HDMI_1
Signal Type	HDMI
Aspect	3840 x 2160
Scan Mode	Progressive
Color Depth	8

[Save System Settings](#)

- The **Save As** dialog box will be displayed. Select the folder where the file will be saved. Click the **Save** button to save the file.
- Click **Firmware**, on the left side of the screen.

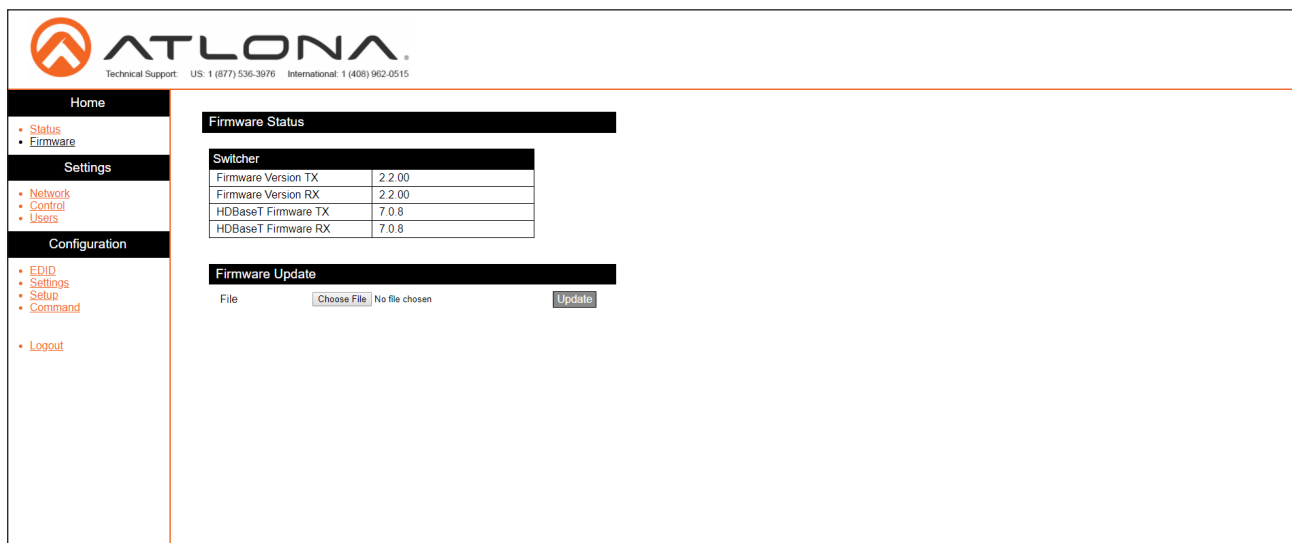

Firmware Status

Switcher

Firmware Version TX	2.2.00
Firmware Version RX	2.2.00
HDBaseT Firmware TX	7.0.8
HDBaseT Firmware RX	7.0.8

Firmware Update

File: No file chosen

- Click the **Choose File** button, to select the firmware file.
- Click the **Update** button. A progress bar will be displayed during the update process.
- Once the update has been completed, re-login to the webGUI.

Cable Termination

Atlona recommends EIA/TIA-568-B termination. Connector type and size is very important to ensure extenders work correctly. Always use the matching cable type with the correct RJ45 connector.

- CAT5e cables should use only CAT5e RJ45 connectors
- CAT6 cables should use only CAT6 connectors
- CAT6a cables should use only CAT6a connectors
- CAT7 cables should use only CAT7 connectors

Using the wrong size connectors may result in interference causing loss of signal.

WARNING: EZ RJ45 connectors are not recommended with HDBaseT extenders. Doing so may result in interference with audio and video transmission.

EIA/TIA 568-B Termination

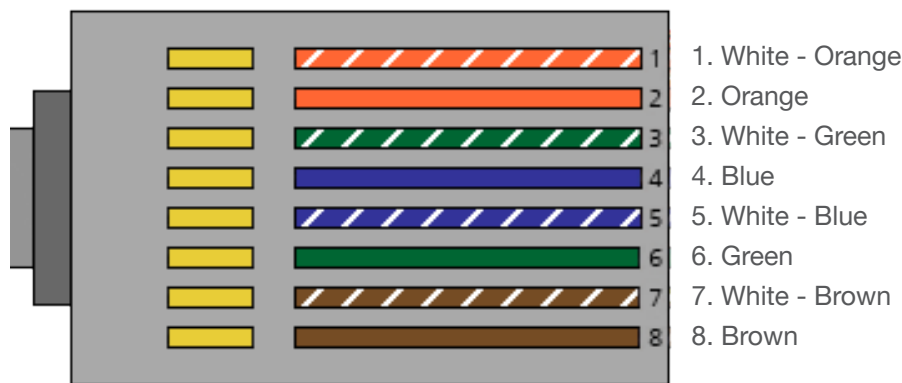

Refer to the tables below for recommended cabling when using Atlona products with HDBaseT. The green bars indicate the signal quality when using each type of cable. Higher-quality signals are represented by more bars.

Core	Cable Type	CAT5e	CAT6	CAT6a	CAT7
Solid	Unshielded Twisted Pair (UTP)	■ ■	■ ■	N/A	N/A
	Shielded Twisted Pair (STP)	■ ■ ■ ■	■ ■ ■ ■	■ ■ ■ ■ ■ ■	■ ■ ■ ■ ■ ■

IMPORTANT: Stranded or patch cables are not recommended due to performance issues.

Default Settings

The following tables list the factory-default settings for the AT-UHD-HDVS-300-TX.

Feature	Settings	
Network	DHCP	ON
	Telnet Port	23
	HTTP Port	80
	IP Timeout	300
	Hostname	AT-UHD-HDVS-300-[last five digits of serial number]
	Telnet Login Mode	OFF
Control	Key Lock	OFF
	RS-232 Control	Control
	Baud rate	115200
	Data bit	8
	Parity	None
	Stop bit	1
Users	Admin username	root (cannot be changed)
	Admin password	Atlona
EDID	HDMI 1	SINK
	HDMI 2	SINK
	VGA	SINK
	DisplayPort	SINK
	HDMI 5	SINK
HDCP	HDMI 1	Compliant
	HDMI 2	Compliant
	VGA	Non Compliant
	DisplayPort	Compliant
	HDMI 5	Compliant
Settings	Auto switch	On
	Fallback input	Previous
	Switch Timeout	10 seconds
	Lockout	None
	Input Selection	HDMI 1
	USB Host	Follow Video
Setup	Power command	RS-232
	Volume / Mute	RS-232
	Retry Timeout	500 milliseconds
	Lock Power Button	Disabled
	Display Switch Mode	Command On/Off, AV No Change
	Display Auto Power On	Off
	Display Auto Power Off	Off
	Lamp Cool Down Timer	5 seconds
	Auto Power Off Timer	5 seconds
	Display Warm-Up Timer	5 seconds
	Volume Repetition Rate	200 milliseconds
Command	Transmission type	ASCII
	Feedback Verify	Off
	Comma delimiter interval	5 seconds

Specifications

Connectors, Controls, and Indicators	Transmitter	Receiver
HDMI IN	2 - Type A, 19-pin female	1 - HDMI Type A, 19-pin female
HDMI OUT	1 - Type A, 19-pin female	n/a
DP IN	1 - 20-pin female	n/a
VGA IN	1 - DE15, female	n/a
USB	2 - Type A, 4-pin female 2 - Type B, 4-pin female	3 - USB Type A, 4-pin female
RS-232	1 - 3-pin captive screw	1 - 3-pin captive screw
AUDIO	1 - 3.5 mm mini-stereo	n/a
HDBaseT	1 - RJ45, shielded	1 - RJ45, shielded
LAN	1 - RJ45, sheilded	1 - RJ45, sheilded
DC 48V	n/a	1 - 2-pin, captive screw
Power button	1 - momentary, tact-type	n/a
Cursor buttons	2 - momentary, tact-type	n/a
Input select button	1 - momentary, tact-type	n/a
Video input indicators	5 - LED, blue	n/a
PWR indicator	n/a	1 - LED, green
LINK indicator	n/a	1 - LED, amber

Video	
UHD/HD/SD	4096×2160@24/25/30/50*/60Hz*, 3840×2160@24/25/30/50*/60Hz*, 2048×1080p, 1080p@23.98/24/25/29.97/30/50/59.94/60Hz, 1080i@50/59.94/60Hz, 720p@50/59.94/60Hz, 576p, 576i, 480p, 480i
VESA	2560×2048, 2560×1600, 2048×1536, 1920×1200, 1680×1050, 1600×1200, 1600×900, 1440×900, 1400×1050, 1366×768, 1360×768, 1280×1024, 1280×800, 1280×768, 1152×768, 1024×768, 800×600, 640×480
Color Space	YUV, RGB
Chroma Subsampling	4:4:4, 4:2:2, 4:2:0*
Color Depth	8-bit, 10-bit, 12-bit

Audio	
HDMI IN & HDBaseT OUT	PCM 2Ch, LPCM 5.1, LPCM 7.1, Dolby® Digital, DTS® 5.1, Dolby Digital Plus™, Dolby TrueHD, DTS-HD Master Audio™, Dolby Atmos®, DTS:X
Sample Rate	32 kHz, 44.1 kHz, 48 kHz, 88.2 kHz, 96 kHz, 176.4 kHz, 192 kHz
Bit Rate	24-bit (max.)

Resolution / Distance	4K - Feet	4K - Meters	1080p - Feet	1080p - Meters
CAT5e/6	230	70	330	100
CAT6a/7	330	100	330	100
HDMI IN/OUT	15	5	30	10

*4096×2160@50/60Hz & 3840×2160@50/60Hz supported @ chroma subsampling 4:2:0 8-bit only.

Signal	
Maximum TMDS Clock	300 MHz
HDBaseT	10.2 Gbps
HDMI	1.4
DisplayPort	1.2, dual mode
USB	2.0
HDCP	1.4
CEC	Yes

Temperature	Fahrenheit	Celsius
Operating	32 to 104	0 to 40
Storage	-4 to 140	-20 to 60
Humidity (RH)	20% to 90%, non-condensing	

Power	
Consumption	23 W
Idle Consumption	15 W
Supply	Input: 100 - 240 V AC, 50/60 Hz, Output: 48 V DC, 0.83 A

Dimensions	Inches	Millimeters
H x W x D (TX)	1.73 x 8.75 x 10.28	44 x 224.25 x 261
H x W x D (RX)	1.02 x 4.29 x 5	26 x 109 x 127

Weight	Pounds	Kilograms
Device (TX)	2.65	1.2
Device (RX)	0.62	0.28

Certification	
Device	CE, FCC
Power Supply	CE, FCC, Level VI, RoHS, cULus, RCM, CCC

Index

A

Appendix 43

C

Configuration

IP. See IP configuration

Connection

diagram 11

instructions 11

Contents

package 8

Control

RS-232 23

Customer support 3

D

Default settings 46

Description

front / rear panel 9

E

EDID

presets 36

F

FCC statement 6

Features 8

Firmware

displaying 31, 32

I

Installation 11

IP configuration

using commands 15

using the front panel 14

using the web GUI 16

O

Operating notes 3

P

Panel descriptions 9

Password

changing 35

default 29

Power

connector 11

R

RS-232 control

control mode 25

pass-through mode 23

S

Safety information 6

Specifications 47

T

Termination

cabling guidelines 45

Timer

auto power-off 40

display warm-up 40

lamp cool down 40

U

USB modes

follow USB 21

follow video 17

manual 22

Users

primary user name 29

W

Warranty 4

Web GUI 29

